



Vaasan yliopisto
UNIVERSITY OF VAASA

OSUVA Open
Science

This is a self-archived – parallel published version of this article in the publication archive of the University of Vaasa. It might differ from the original.

Prospects and costs for reactive power control in Sundom smart grid

Author(s): Sirviö, Katja; Väلكkilä, Lasse; Laaksonen, Hannu; Kauhaniemi, Kimmo; Rajala, Arto

Title: Prospects and costs for reactive power control in Sundom smart grid

Year: 2018

Version: Accepted manuscript

Copyright ©2018 IEEE. Personal use of this material is permitted. Permission from IEEE must be obtained for all other uses, in any current or future media, including reprinting/republishing this material for advertising or promotional purposes, creating new collective works, for resale or redistribution to servers or lists, or reuse of any copyrighted component of this work in other works.

Please cite the original version:

Sirviö, K., Väلكkilä, L., Laaksonen, H., Kauhaniemi, K., & Rajala, A., (2018). Prospects and costs for reactive power control in Sundom smart grid. In: *2018 IEEE PES Innovative Smart Grid Technologies Conference Europe (ISGT-Europe)*. IEEE. <https://doi.org/10.1109/ISGTEurope.2018.8571695>

Prospects and Costs for Reactive Power Control in Sundom Smart Grid

Katja Sirviö
University of Vaasa
Vaasa, Finland
katja.sirvio@uva.fi

Kimmo Kauhaniemi
University of Vaasa
Vaasa, Finland
kimmo.kauhaniemi@uva.fi

Lasse Välikilä
University of Vaasa
Vaasa, Finland
lasse.valkkila@uva.fi

Arto Rajala
University of Vaasa
Vaasa, Finland
arto.rajala@uva.fi

Hannu Laaksonen
University of Vaasa
Vaasa, Finland
hannu.laaksonen@uva.fi

Abstract—New options to provide the technical ancillary services locally and system-wide by distributed energy resources (DER) are needed in the future. Sundom Smart Grid (SSG), local smart grid pilot in Vaasa, offers a novel research platform to develop protection and control solutions for future distribution networks. In this study, an ancillary service solution for reactive power management was studied by utilizing measured data and available MV and LV network connected DER units. Different requirements for reactive power flow between distribution and transmission network were considered in the studies. Based on these requirements “Future Reactive Power Window” was formulated for SSG. The reactive power flow across voltage levels in different cases was studied by simulations. Simulations showed that a coordinated reactive power management scheme across different voltage levels is very important from the technical and the economical point of view for development of future distribution networks.

Keywords—Smart Grid, Microgrid, Active Network Management, Reactive Power Control

I. INTRODUCTION

Options for ancillary services are one main focus on the development of Smart Grids, which is a result but also a possibility due to massive implementation of distributed generation (DG) units. The integration of DG units is well studied, but solutions for the coordinated management of ancillary services across different voltage levels and for the benefit of different stakeholders have not been that much in focus [1]–[3]. Sundom Smart Grid, Innovation Cell Finland in DeCAS project, enables the development of ancillary service solutions for future grids over traditional boundaries from the high voltage level until to the LV level.

In this paper different requirements for reactive power flow have been studied. EU sets grid code requirements, for example, for connection of demand and generators. Further local TSO set requirements for active power flow dependent reactive power flow (P_{flow} and Q_{flow}) by “Reactive Power Window”. In addition, reliable and future-proof islanding detection as well as possibility to make stable transition to islanded operation sets requirements for reactive power flow control.

In this paper the reactive power flow (Q) across different voltage levels is studied by the developed simulation models.

This work was carried out in Demonstration of Coordinated Ancillary Services (DeCAS) research project coordinated by (<http://www.decas-project.eu>). This project has received funding in the framework of the joint programming initiative ERA-Net Smart Grids Plus, with support from the EU’s Horizon 2020 research and innovation program.

Eight of these cases in which the effects of Q control were investigated are presented in the following sections. Section II presents the SSG and the requirements for the Q management. Then in Sections III–V the used simulation model is described and eight study cases and reactive power fee comparisons are presented. Finally summary from simulations, conclusions and future research questions are presented in Section V.

II. LIVING LAB SUNDOM SMART GRID

SSG is a pilot living lab jointly created by ABB, Vaasan Sähköverkko (DSO), Elisa (communications) and University of Vaasa [4]. The overview of the system is presented in Fig. 1. Real-time measurements are gathered from the MV distribution network on-line, from all four feeders at a HV/MV substation as well as from three MV/LV substations comprising 20 measurement points totally. The measured data is IEC 61850 stream with current and voltage measurements. The sampling rate is 80 samples per a cycle, which is 4000 samples/s. In addition power, frequency, RMS voltages, currents etc. measurements are received by GOOSE messages. The data is collected to servers for providing data also for future research.

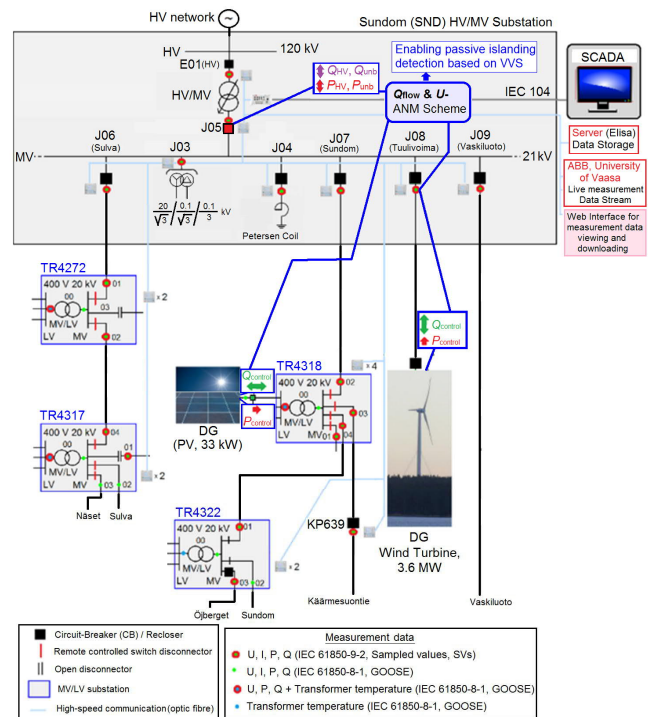

Fig. 1. On-line diagram of Sundom Smart Grid living lab.

III. OBJECTIVES OF REACTIVE POWER MANAGEMENT

In this study the Q management was considered by the means of primary local control method, which target is to manage *reactive* power flow within voltage and thermal current limits. The secondary local control method designed to manage *active* power flow within voltage and thermal current limits. The secondary control method can be used if voltage and thermal limits or stable transition to island operation cannot be achieved with primary control. [5], [6]

A. Reactive Power Window of Transmission System Operator

The reactive power window settled by Fingrid, TSO in Finland, presented in Fig. 2 is specifying the reactive power Q that is allowed to be delivered or received from the main grid without fees. The limits are set according to whether active power P is produced or consumed in the customers' connection point of the main grid.

The measured points are hourly average values of power, and the reviewing period is 12 months. The points out of the window (Q_m, P_m) are invoiced, but the 50 largest excesses of the Q limits within one month are not noticed. In addition, the reactive energy fee is defined.[7]

B. EU Regulation

EU commission regulation Network Code of Demand Connection set requirements of reactive power management for the transmission connected distribution systems, and it should be applied to new distribution systems to provide demand response (DR) services to relevant system operators and relevant TSOs. The requirements should not apply to existing distribution systems. The requirements also should not apply to new or existing demand facilities connected at the distribution level unless they provide DR services to relevant system operators and relevant TSOs. However, the requirements should apply in case the relevant regulatory authority or EU member state decides otherwise.[8]

TSO may require DSOs to actively control the exchange of reactive power. Secondly a DSO may require the TSO to consider utilizing the distribution network for reactive power management. The actual reactive power range should not exceed 48 % of maximum capacity to import or export of active power (P_{max}), which means when importing (consuming) reactive power $\cos\phi_{max} = 0,9_{ind}$, and when exporting (producing) reactive power $\cos\phi_{max} = 0,9_{cap}$. In addition TSO may require that it is not allowed to export reactive power in the situation where active power import is below $0,25P_{max}$. In Fig. 3 is presented these requirements outlined for SSG, and it is based on 8 MW peak power. [8]

In addition, requirements for grid connection of generators [9] set requirements for reactive power management for voltage stability purposes for new installations.

C. Microgrids

In addition to the above, when considering reliable islanding detection for Microgrids, Q_{flow} and P_{flow} have to be managed in a way that the magnitudes are not in NDZ (Non Detection Zone). Also at the situation when the network is able to transfer to the island operation, a zone for stable transition has to be adopted. [5], [6], [10]

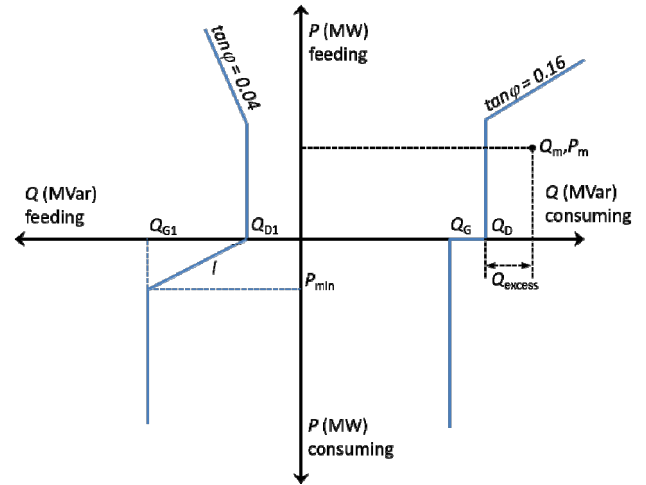

Fig. 2. Fingrid's reactive power window. Applied from [7].

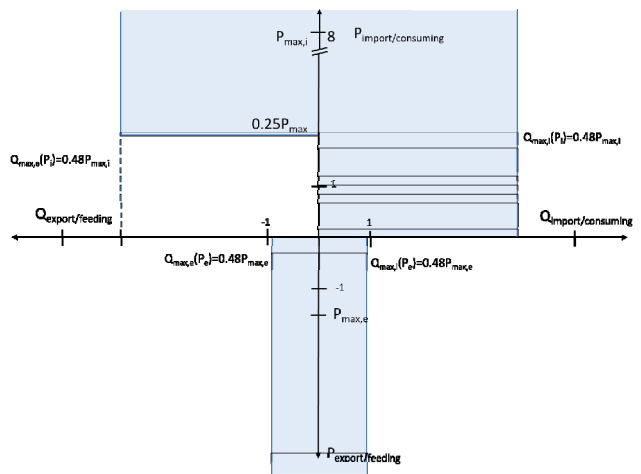

Fig. 3. Requirements set in Network code of demand connection applied for SSG.

Based on studies and PSCAD simulations [11] there are limits for Microgrids. The a-limits enable the reliable islanding detection in every situation considering the limits for NDZ when using e.g. VVS (Voltage Vector Shift) based loss-of-mains protection. In the blind spot area the system is too close to power balance situation for detecting islanding based on a change of VVS. The limits for SSG should be $Q_a \pm 50$ kVar and $P_a \pm 30$ kW. The b-limits enables the distribution system to transfer to island operation in a way the frequency and voltage stability is possible to maintain after islanding. The limits for SSG should be $Q_b \pm 300$ kVar and $P_b \pm 150$ kW. These limits are presented in Fig. 4.

D. Reactive Power Management for Future Smart Grid

The operation limits for reactive power management for SSG in the future could be observed by the previously presented limitations. The "Future Reactive Power Window" could look like the limits presented in Fig. 4. The TSO requirements and the requirements for Microgrids are combined, in addition on the back-ground there is the EU requirements. Limits for the max. active power is based on the measured data the year 2016, when $P_{max,import}$ was 8,3 MW and $P_{max,export}$ was 1,975 MW.

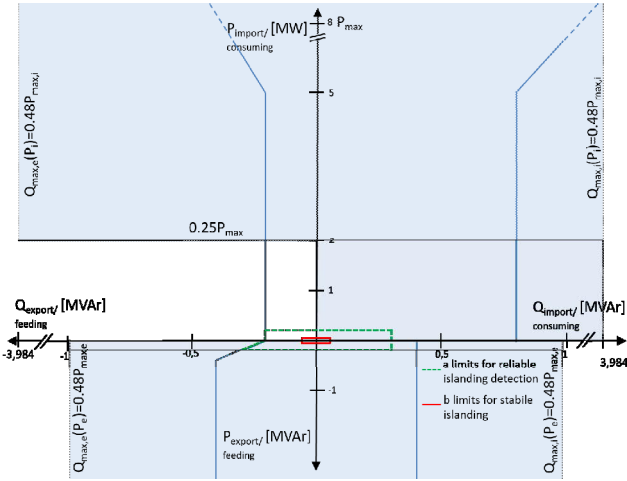

Fig. 4. Active and reactive power operation limits for future SSG.

The observation point according to [7] is 110 kV side of the primary transformer, but the potential point for islanding is the 21 kV side. This means that the distribution network the primary transformer is supplying is the area for which the limits a and b are defined. In some other case these limits could be set for a MV feeder or for a secondary transformer i.e. in the point where an intended islanding operation is desired. Voltage and thermal current limits have to be fulfilled at every network point. This can be based on the measurements or on estimated values.

In this study, Fingrid's reactive power window was considered for reactive power management by the different use cases. A control algorithm was developed for managing Q_{flow} . Moreover, a control algorithm was developed providing Q control for the reliable islanding detection and for the stable transition to intended island operation.

IV. THE SIMULATION MODEL

The simulation model, presented in Fig. 5, was developed with Matlab/Simscap Power System. The model is based on "One-Year Simulation in One Minute" model [12], which simulates in phasor simulation mode one year P and Q flows based on hourly load and generation data.

A. Main Grid and Primary Transformer

The main grid was modelled as a three-phase source with phase-to-phase voltage of 134.585 kV (the highest voltage based on primary transformer tap positions). Short circuit level was 100 MVA and base voltage 110 kV. The U_n of the primary transformer was 117/21 kV and S_n was 16 MVA. On load tap changer (OLTC) was not modelled because using an OLTC model of a transformer caused the simulation speed to slow down too much.

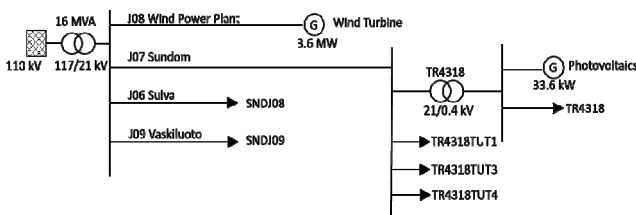

Fig. 5. The network structure of the simulation model.

TABLE I. LINE LENGTHS IN SUNDOM SMART GRID

Feeder	Overhead [m]	Cable [m]	Sum [m]	Cabling degree
J06 Sulva	25246	7938	33184	23,9 %
J06 Sulva 2028	0	40756	40756	100,0 %
J07 Sundom	12950	10199	23149	44,1 %
J07 Sundom 2028	8200	16372	24572	66,6 %
J08 Wind	0	733	733	100,0 %
J09 Vaskiluoto	5913	1122	7035	15,9 %
J09 Vaskiluoto 2028	3340	4467	7807	57,2 %
Total 2018	44109	19992	64101	31,2 %
Total 2028	11540	62328	73868	84,4 %

TABLE II. DISTRIBUTION OF THE ELECTRICITY USERS IN SUNDOM SMART GRID

Feeder	Group 1	Group 2	Group 3
J06 Sulva	39,5 %	44,1 %	16,4 %
J07 Sundom	29,0 %	47,5 %	23,5 %
J09 Vaskiluoto	1,3 %	5,2 %	93,5 %

B. Lines

The overhead lines and the cables were modelled, presented in Table 1, by considering lengths of different conductor types. In future it is planned to increase cabling degree, which is also shown in the table as year 2028.

C. Load

The loads in feeders J06, J07 and J09 were modelled so one can be selected to be either constant power load or dynamic load, but only the constant power loads were considered. Since the consumption data available from the real system measurements was diffused and available only for some months, a consumption data model was generated based on the data in May 2017 and using "Typical load profiles" (TLP) [13] to extend it for the whole year.

TLP customers in Finland are classified as user groups 1...3. Group 1 includes household customers, which electricity consumption is 10 MWh/year at highest. Group 2 includes household customers, which electricity consumption is above 10 MWh/year. Group 3 includes others, like cottages. The distribution of the electricity users as user groups in SSG is presented in Table 2. [13]

The load profiles were generated for feeders SNDJ06 Sulva and SNDJ09 Vaskiluoto. Feeder SNDJ07 Sundom was modelled in more details. In addition one year data AMR measurements from the LV side of the distribution transformer TR4318 was utilized for load modelling on the LV side.

D. Wind Power Plant

The wind turbine was 3.6 MW PMG synchronous generator type and the converter was a full power IGCT type [14]. The wind generator (WG) was modelled as an ideal WG or a controlled power source. Wind data was generated by combining data from Klemetilä weather station [15] near Sundom and data available from Tuuliatlas [16]. Wind measurements at Klemetilä weather station are available at 27 m high, but the turbine hub is 90/125 m high, so the wind speed data is tuned according to Tuuliatlas data. Power varies as a function of the wind speed.

E. Distribution Transformer

One distribution transformer TR4318 and its LV network were modelled including a 33.6 kWp PV system. The nominal voltage of the distribution transformer was 21/0.4 kV and the nominal power was 315 kVA.

F. Photovoltaic System

Solar irradiation data was generated from classic database of Photovoltaic Geographical Information System (PVGIS) [17], which was obtained hourly profiles of solar irradiance estimates on a fixed plane [W/m²].

V. STUDY CASES AND COMPARISONS OF REACTIVE POWER FEES

Eight case studies were developed for investigating the P and Q flows. The first case represented the present situation in Sundom Smart Grid. With Case 2 and 3 the possibilities to consume reactive power were evaluated. Previous presents a situation where a shunt reactor was added to 21 kV bus and the latter a situation where the WG converter consumed Q at full power. Case 4 represented a situation where both the WG unit and the PV unit are consuming Q according to constant power factor. By Case 5 it was demonstrated an ideal Q control, which fulfills the conditions for reactive power window whereas by Case 6 it was demonstrated control fulfilling conditions for reactive power window as well as conditions for Q control for Microgrid islanding detection. Case 7 demonstrated a situation where amount of PV panels were increased. Finally by Case 8 it was evaluated the effect of the increase of the cabling degree.

A. Case 1 – State of the Art

This simulation case indicated the present situation of the reactive power flow in the Sundom Smart Grid. Power factor of the WG converter was set 0,97_{ind} based on the measurements May 2017. The reactive power window at TSO (110 kV) side is presented in Fig. 6. The “reactive power window” at DSO (21 kV) side was ~ 70 kVAr more consuming because of the effect of the primary transformer inductance. The result of the simulation was that 3054 (Q, P) points were out of the window.

B. Case 2 – Shunt Reactor Added

A shunt reactor was dimensioned to the network when there was no reactive power consumption than loads. First in Case 2a it was simulated the situation that WG was not injecting or consuming reactive power ($\cos\phi = 1$). Then in Case 2b a shunt reactor ($L_{\pm} = 4$ H, $L_0 = 8$ H) was modelled to 20 kV bus. The result of Case 2a was that 6800 (Q, P) points were out of the window and 163 points in Case 2b respectively, which is presented in Fig. 7.

C. Case 3 – Consumption of Q at WG with Full Power

WG converter was set up to consume Q all the time at the full S_N and $\cos\phi = 0,95_{\text{ind}}$, which means $Q_{\text{max}} = 1,124$ MVar. This simulation case indicated the potential of the WG converter to consume the reactive power of the network.

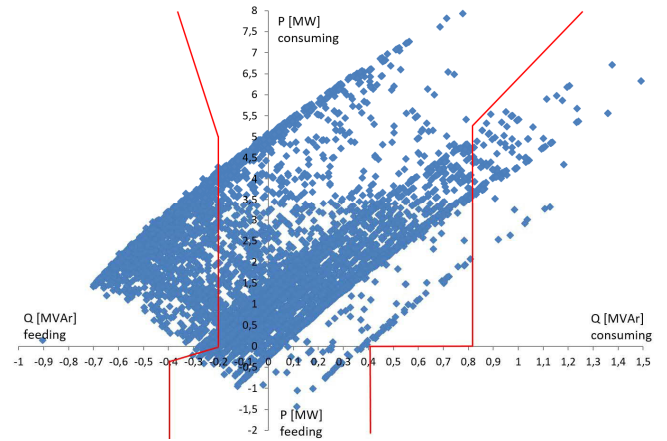

Fig. 6. Reactive power window at 110 kV side of the primary transformer in Case 1.

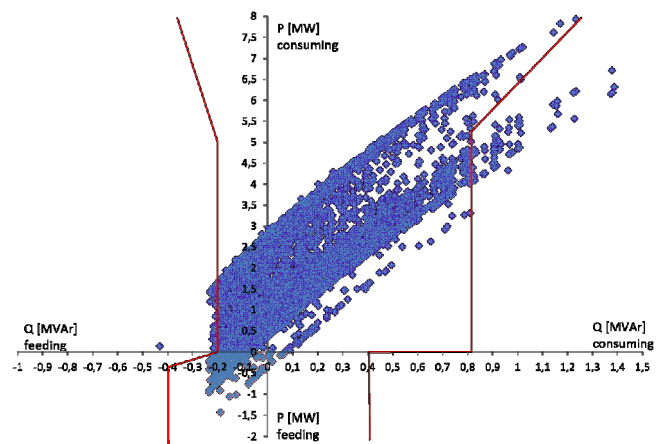

Fig. 7. Reactive power in Case 2b.

D. Case 4 – Consumption of Q at WG and PV According to Power Factor

WG converter was set up to consume Q according to P with $\cos\phi = 0,95_{\text{ind}}$ and PV inverter $\cos\phi = 0,95_{\text{ind}}$ respectively. The result of the simulation was that 3046 (Q, P) points were out of the window.

E. Case 5 – Ideal Control

WG converter was set up to consume reactive power according to the simulated reactive power (Q_{window}) at the primary transformer 110 kV side. In other words this control method was attempting to drive Q to zero i.e. $Q_{\text{set}} = -Q_{\text{meas}}$. The result of the simulation was that no (Q, P) points were out of the window.

F. Case 6 – Control Algorithm

The TSO's requirements of reactive power window and in addition NDZ requirement of $Q \pm 50$ kVAr to enable islanding detection was studied. In Case 6a the control algorithm was generated for “Reactive power Window” requirements, so the target value was $Q = 0$ if (Q, P) is out of the window otherwise no control. The result of the simulation was that 0 (Q, P) points were out of the window. The reactive power window is presented in Fig. 8.

In Case 6b the idea of the control algorithm action was check if (Q_i, P_i) were out of the window or in the NDZ area. If the point was out of the window, the algorithm drove $Q_{set} = \pm 50$ kVar depending on the direction. If the point was in the NZD, the algorithm drove $Q_{set} = Q_i \pm 50$ kVar depending on the direction of Q_i . If the point was inside the window and out of NDZ no control action was done. The result of the simulation was that no (Q, P) points were out of the window. The reactive power window is presented in Fig. 9.

G. Case 7 – Increase of PV Systems

The amount of PV panels was increased from 300 m² to 4000 m² at the LV distribution network. In Case 7a the inverters were set up to consume Q at $\cos\varphi = 0,8_{ind}$ and the wind generator $\cos\varphi = 1$. In the Case 7b $\cos\varphi = 1$ both to the PV inverters and WG converter. The result of the simulation 7a was that 6147 (Q, P) points were out of the window and 6788 respectively in Case 7b.

H. Case 8 – cabling 2028

The effect of increased cabling was investigated according to Table 1. In Case 8a the WG converter was set up consume reactive power at $\cos\varphi = 0,95$. In Case 8b the WG converter was set up to consume Q at full power (compare to Case 3). The result of the simulation in Case 8a was that none of (Q, P) points were inside the window and in Case 8b 8697 points were out of the window.

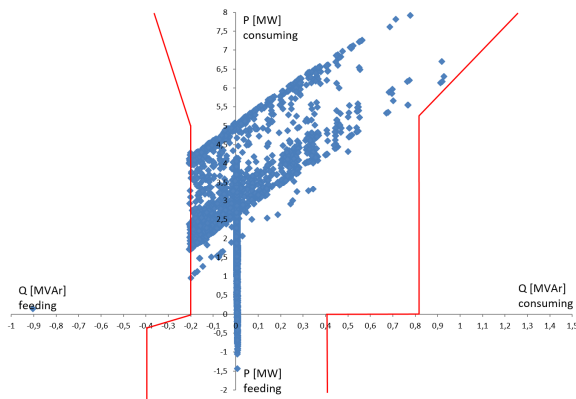

Fig. 8. Reactive power window in Case 6a.

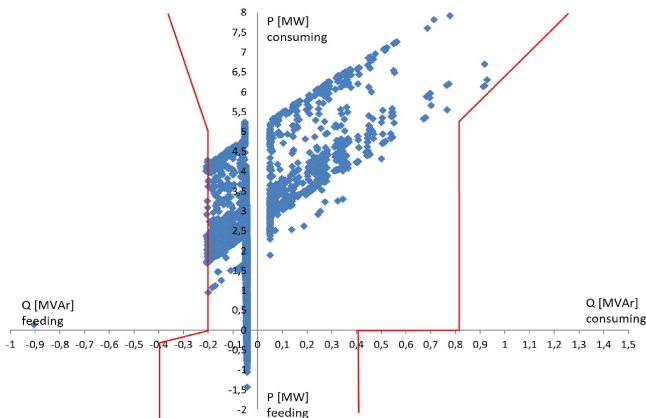

Fig. 9. Reactive power window in Case 6b.

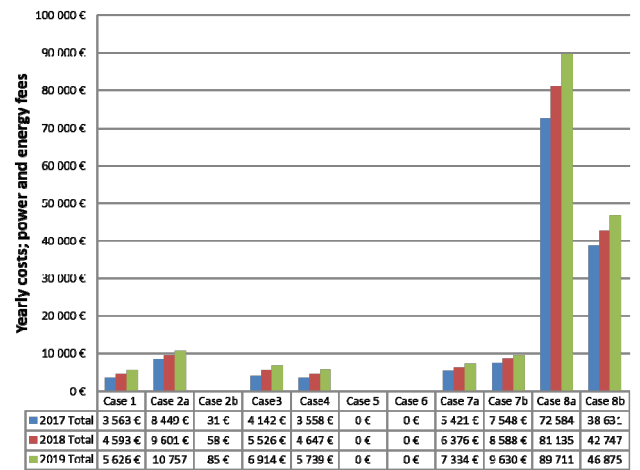

Fig. 10. Yearly fees for reactive power flows in Sundom Smart Grid.

I. Reactive Power Fees in Different Cases

The yearly reactive power and energy fees according to the different case studies are presented in Fig. 10. In this study cost are considered to comprise of TSO fees only. There are unnecessary expenses caused by reactive power, which lead to potential saving opportunities with optimizing the Q control. Increasing the cabling degree in the future causes the fees rise significantly and the utilization of the Q control becomes even more essential. [18]

VI. SUMMARY OF THE SIMULATIONS AND CONCLUSIONS

Based on the simulations the Q control in SSG today could be implemented by controlling the converter of the WG unit. By comparing results of Case 3 and Case 8 it can be discovered that the Q control by the WG converter is inadequate in future because the lack of its potential to compensate the capacitive impedance of the increased amount of cables. However the increase of the P consumption in future is not taken in account, which will decrease the amount of capacitive Q formed by the cables. One solution for future SSG could be a shunt reactor installed to the MV bus and then control the Q by the WG converter so the requirements for Q control introduced in section III will be fulfilled. Naturally one WG unit more with a full scale converter like today could be one option.

Case 7 demonstrated the effect of the PV inverter to Q management. By comparing simulation results Case 2a and 7b it can be noticed that there is a slight positive effect to decrease the injecting of reactive power to the main grid. With 4000 m² of panels, the generated active power was up to 425 kW and consumed reactive power was up to 250 kVar according to power factor control of the inverter ($\cos\varphi = 0,8_{ind}$). In order to affect the reactive power control by PV inverters at the LV level, the amount of the panels should increase notably.

Considering requirements for Microgrids and the reliable islanding detection by the management of Q_{flow} and P_{flow} , the control algorithm for Q of the WG converter was developed in Case 6b. In addition the P control should be studied in future studies, which could be established by utilising an energy storage system, by the means of demand response or by limiting power generation of the WG unit or the PV systems.

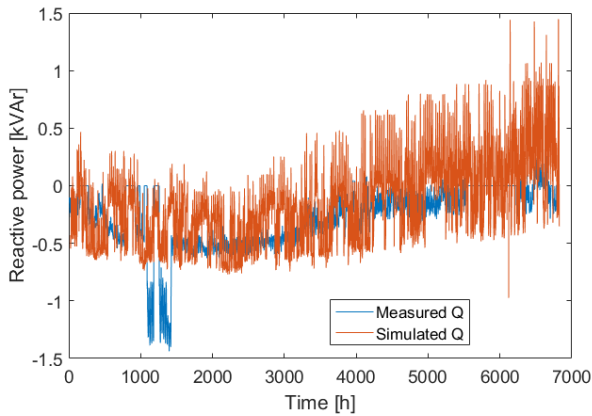

Fig. 11. Measured and simulated reactive power profiles at SNDJ05.

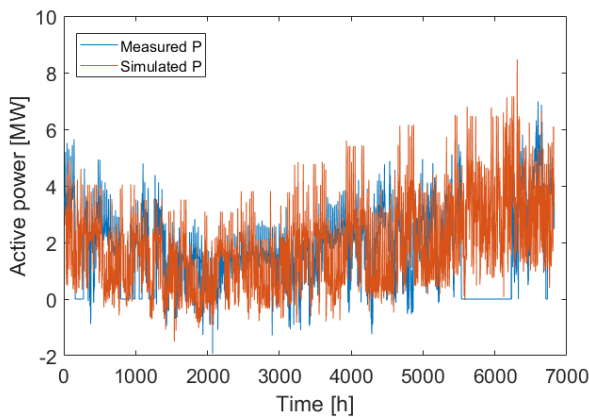

Fig. 12. Measured and simulated active power profiles at SNDJ05.

For evaluating the simulation results, the data available from SSG was gathered from 22nd April 2017 until 30th January 2018, which means about nine month data. Fig. 11 presents measured and simulated reactive power profiles on that time slot. Fig. 12 presents in turn active power profiles.

The generated simulation model could be utilized for the future studies. Different case studies could be implemented by the model. By implementing one year measured data (consumption and power generation) to the model more accurate model is obtained. Modelling an accurate "Reactive Power Window" of 21 kV side for future SSG is essential for further studies of reactive power control.

For control studies the measured data could be implemented as shorter period of time. For the studies of ancillary services, modelling of LV distribution networks, energy storage system and demand response actions as well as developing control algorithms are essential. These all will provide the means of further research of ancillary services provided by SSG, but also Microgrid operations. Adapting the model for the real time simulator creates a frame for hardware in the loop testingevaluated

REFERENCES

[1] K. Kosovinc, "Volt/var control", Literature Research, Technical Report of DeCAS Research Program, Vienna 2017.

[2] M. Tahir, M. E. Nassar, R. El-Shatshat and M. M. A. Salama, "A review of Volt/Var control techniques in passive and active power distribution networks," 2016 IEEE Smart Energy Grid Engineering (SEGE), Oshawa, ON, 2016, pp. 57-63.

[3] S. Satsangi and G. B. Kumbhar, "Review on Volt/VAr optimization and control in electric distribution system," 2016 IEEE 1st International Conference on Power Electronics, Intelligent Control and Energy Systems (ICPEICES), Delhi, 2016, pp. 1-6.

[4] European Commission, "Sundom Smart Grid", EU Project Description, Available: <https://ses.jrc.ec.europa.eu/sundom-smart-grid-ssg> [Accessed: 24-Oct-2017].

[5] H. Laaksonen and P. Hovila, "Future-proof islanding detection schemes in Sundom Smart Grid," CIRED Conference on Electricity Distribution, 12-14 June 2017, Glasgow

[6] H. Laaksonen and P. Hovila, "Flexzone concept to enable resilient distribution grids — Possibilities in Sundom Smart Grid," CIRED Workshop 2016, Helsinki, 2016, pp. 1-4.

[7] Fingrid, "Supply of reactive power and maintenance of reactive power reserves", Application Instruction, 2017, Available at: http://www.fingrid.fi/en/customers/Customer%20attachments/Grid%20service/Supply%20of%20Reactive%20Power%20and%20Maintenance%20of%20Reactive%20Power%20Reserves_2017.pdf [Accessed: 24-Oct-2017].

[8] Commission Regulation (EU) 2016/1388. Network code on demand connection. 17 August 2016. Available: <https://publications.europa.eu/en/publication-detail/-/publication/514fd1e3-650b-11e6-9b08-01aa75ed71a1/language-en/format-PDF/source-44168342> [Accessed: 24-Oct-2017].

[9] Commission Regulation (EU) 2016/631. Network code on requirements for grid connection of generators. 14 April 2016. Available: <https://publications.europa.eu/en/publication-detail/-/publication/1267e3d1-0c3f-11e6-ba9a-01aa75ed71a1/language-en> [Accessed: 24-Oct-2017].

[10] S. Uebermasser, C. Groiss, A. Einfalt, N. Thie, M. Vasconcelos, J. Helguero, H. Laaksonen and P. Hovila, "Requirements for coordinated ancillary services covering different voltage levels," CIRED Conference on Electricity Distribution, 12-14 June 2017, Glasgow

[11] H. Laaksonen, P. Hovila and K. Kauhaniemi, "Combined islanding detection scheme utilizing active network management for future resilient distribution networks," The 14th International Conference on Developments in Power System Protection (DPSP 2018), unpublished, Belfast, UK

[12] P. Giroux, G. Sybille, J. Brochu, and P. Brunelle, "One-year simulation in one minute, Simulation Model of an Energy Storage System Used on a Power Grid," Available: <https://se.mathworks.com/matlabcentral/fileexchange/51137-one-year-simulation-in-one-minute> [Accessed: 24-Oct-2017].

[13] Council of State Finland, "2009/66 Valtioneuvoston asetus sähköntoimitusten selvityksestä ja mittauksesta", Available: <http://www.finlex.fi/fi/laki/ajantasa/2009/20090066#L5P2> [Accessed: 24-Oct-2017].

[14] Mervento, Mervento 3.6-118, Datasheet. Available: <https://en.wind-turbine-models.com/turbines/296-mervento-3.6-118> [Accessed: 24-Oct-2017].

[15] Ilmatieteen laitos, Observation stations, Available: <http://en.ilmatieteenlaitos.fi/observation-stations> [Accessed: 30-Oct-2017].

[16] Ilmatieteen laitos, Suomen tuuliatlas, Available: <http://www.tuuliatlas.fi> [Accessed: 30-Oct-2017].

[17] JRC Renewable Energies Unit (EU Science Hub), Photovoltaic Geographical Information System - Interactive Maps, Geographical Assessment of Solar Resource and Performance of Photovoltaic Technology, Available: <http://re.jrc.ec.europa.eu/pvgis/apps4/pvest.php> [Accessed: 24-Oct-2017].

[18] L. Välikilä and A. Rajala, "Market models for future active network management schemes and effects to different parties" Technical Report of DeCAS Research Program - Deliverable 4.2.1, unpublished.