



## Transmission-constrained optimal allocation of price-maker wind-storage units in electricity markets

Hossein Chabok<sup>a</sup>, Jamshid Aghaei<sup>a,b,\*</sup>, Morteza Sheikh<sup>a</sup>, Mahmoud Roustaei<sup>a,g</sup>, Mohsen Zare<sup>c</sup>, Taher Niknam<sup>a</sup>, Matti Lehtonen<sup>d</sup>, Miadreza Shafi-khah<sup>e</sup>, João P.S. Catalão<sup>f</sup>

<sup>a</sup> Department of Electrical and Electronics Engineering, Shiraz University of Technology, Shiraz, Iran

<sup>b</sup> School of Energy Systems, Lappeenranta-Lahti University of Technology (LUT), Lappeenranta, Finland

<sup>c</sup> Department of Electrical Engineering, Faculty of engineering, Jahrom University, Jahrom, Fras, Iran

<sup>d</sup> Department of Electrical Engineering and Automation, Aalto University, Espoo, Finland

<sup>e</sup> School of Technology and Innovations, University of Vaasa, Vaasa, Finland

<sup>f</sup> Faculty of Engineering of the University of Porto (FEUP) and INESC TEC, R. Dr. Roberto Frias, 4200-465 Porto, Portugal

<sup>g</sup> Fars Province Electrical Distribution Company, Shiraz, Iran

### HIGHLIGHTS

- Optimal allocation of a Wind-Storage Unit (WSU) is developed.
- Congestion in energy transmission is considered.
- The paper deals with price-maker WSU in electricity markets.
- Unscented Transform is adapted to handle wind power uncertainty.

### GRAPHICAL ABSTRACT

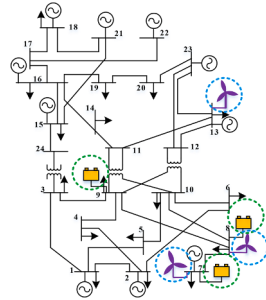

### ARTICLE INFO

#### Keywords:

Transmission switching  
Price-maker  
Microgrid  
Unit allocation  
Congestion

### ABSTRACT

This paper proposes an optimal allocation of a Wind-Storage Unit (WSU). Since transmission lines congestion varies according to the size, the location, and the operation of a generation unit in power systems, we assess the optimal location of a unit as a function of its variable operating condition. An independently operated wind-storage unit is assumed as a price-maker that seeks to maximize its market payoff without any prior information on optimally locating the wind and storage units. The main problem is provided as a tri-level optimization problem in which the first level is the WSU profit maximization, the second level is the power system operation cost minimization from the perspective of the independent system operator (ISO), and the third level is the maximization of the robustness of the system by using an appropriate transmission switching interval robust based chance constrained (TSIRC) method in order to minimize the operation cost of the system and transmission lines congestion problem. The tri-level model is converted to a bi-level optimization model by using Karush-Kuhn-Tucker (KKT) conditions provided as a Mathematical Programming with Equilibrium Constraint (MPEC). An effective binary particle swarm optimization algorithm (BPSO) is used in order to find the optimal

\* Corresponding author at: Department of Electrical and Electronics Engineering, Shiraz University of Technology, Shiraz, Iran. School of Energy Systems, Lappeenranta-Lahti University of Technology (LUT), Lappeenranta, Finland

E-mail addresses: [jamshid.aghaei@lut.fi](mailto:jamshid.aghaei@lut.fi) (J. Aghaei), [mzare@jahromu.ac.ir](mailto:mzare@jahromu.ac.ir) (M. Zare).

<https://doi.org/10.1016/j.apenergy.2022.118542>

Received 30 August 2021; Received in revised form 19 December 2021; Accepted 10 January 2022

Available online 24 January 2022

0306-2619/© 2022 The Authors. Published by Elsevier Ltd. This is an open access article under the CC BY license (<http://creativecommons.org/licenses/by/4.0/>).

location of the wind and storage units. Unscented Transform (UT) as a key element is suggested to model the uncertainties associated with the output power of the wind turbines. The proposed method is tested on an IEEE 24-bus test system and the results reveal the validity of this work.

**Nomenclature**

Sets/Indices

$\Omega^g/g$	Set/index of generators
$\Omega^L/L$	Set/index of dispatchable loads
$\Omega^{WT}/w$	Set/index of WPGs
$\Omega^{ESS}/e$	Set/index of ESSs
$\Omega^T/t$	Set/index of time
$\Omega^{Ln}/Ln$	Set/index of lines
$\Omega^S/s$	Set/index of congestion/contingency scenarios
$\Omega^{bus}/i$	Set/index of buses

Parameters

$\bar{P}_e^{ch,t}/\bar{P}_e^{dch,t}$	Maximum charging/discharging rate of the energy storage systems
$E_e^t/\bar{E}_e^t$	Minimum/maximum energy level of ESS
$\eta^{ch}/\eta^{dch}$	Charging/discharging efficiencies of ESS
$\bar{P}_w^t/\underline{P}_w^t$	Maximum/minimum WPG output
$\underline{P}_L^t/\bar{P}_L^t$	Minimum/maximum dispatchable load
$\bar{P}_{Ln,t}$	Maximum transmission line capacity
$P_{Ln,s}^{cong}$	Decreased transmission capacity due to a congestion in scenarios
$z_{Ln,s}^{cong}/z_{Ln,s}^{cont}$	Parameters for congestion and contingency scenarios
$u_{g,s}$	Binary variable for the unit state in a contingency
$\delta_g^t, \alpha_L^t$	Hourly generator and load price bid
$\theta_i$	Maximum angle of bus $i$
$M$	Big number

$\bar{C}$	Maximum predefined operation cost.
$B_{ij}$	Imaginary part of Y-bus matrix.
$\bar{P}_{f,w}^t$	Wind power forecast.
$\eta_1/\eta_2$	Risk acceptance levels of contingency and congestion, respectively.
$pr_1(Ln,s)/pr_2(Ln,s)$	Probabilities of contingency and congestion scenarios.
<b>Variables</b>	
$\aleph_i^t$	Bus LMP.
$f_1, f_2, \hat{f}_2$	First level, second level and dual problem of second level's objective functions
$X, \bar{X}$	Control variables of primal and dual problems
$P_e^{ch,t}, P_e^{dch,t}$	Hourly charge and discharge power bid of ESS
$E_e^t$	Hourly energy level of the ESSs
$P_w^t, P_g^t, P_L^t, P_e^t$	Hourly power bidding of the WTs, generators, loads and ESSs
$r_e^{dch,t}, r_e^{ch,t}$	Variable indicating whether ESSs are charged/discharged during an hour
$\varphi_w^t, \varpi_e^t$	Hourly bidding prices of WPG and ESS
$SU_g^t, SD_g^t$	Start up and shut down of generators
$P_{Ln}^t$	Hourly line flow
$u_g^t, v_g^t, w_g^t$	Binary variables for commitment, start up and shut down of generators
$\varepsilon_g^t, \hat{\varepsilon}_g^t, \mu_L^t, \hat{\mu}_L^t, \gamma_{Ln}^t, \hat{\gamma}_{Ln}^t, \xi_w^t, \hat{\xi}_w^t$	Lagrangian multipliers
$I_{g,s}^t, I_{e,s}^t, I_{L,s}^t, I_{w,s}^t, I_{\xi_w}^t, I_{\xi_w}^t, I_{\gamma_{Ln}}^t, I_{\gamma_{Ln}}^t$	Binary variables as auxiliary variables

**1. Introduction**

Recently, the development and deployment of distributed energy resources (DERs) have attracted much attention to power system operations. The compatible cost of variable wind power generation (WPG) as well as the necessity for the deployment of energy storage systems (ESSs) have resulted in continuous changes in power system planning and operation. It is envisioned that the optimal planning and operation of WPG and ESS will increase the power system flexibility and reliability, and lower the cost of power system operation [1].

The escalating attention to cleaner environment and the abundance of renewable energy resources have provoked a rapid growth in the utilization of DERs. However, the concerns with the effects of such systems on the existing power grid have led to additional investigations which consider different perspectives [2]. During the last few decades, several numerical methods and solutions have been considered for DER allocation [3–11].

Electricity markets-due to their predominant advantage of providing a fair environment for competition of sellers and buyers-has took the centre stage. In this case, persuasive programs will be of much help to encourage investors to contribute to the expansion of electricity grid improvement programs through different ways (e.g. DERs' investors); by acting as private investors. They seek for a proper profitable, low-risk, stable and worth of investment platform, however. In this regard, an effective allocation procedure is a vast part of what they need to make them sure of a consistent lucrativeness, even in critical occasions of the

system, e.g. congestion and contingency times.

The authors in [3] investigated the ESS allocation along with load shedding in order to improve the power system reliability in contingencies. They stated that such procedures could reduce the annual planning and operation costs including those of resource installation, interruption, and maintenance. In [4], both merits and costs of ESS allocation in a power distribution network with high penetration of WPG were studied. Similar to [3], the authored minimized the annual ESS cost and WPG curtailments. In [5], costs of system upgrades, energy losses and ESS installations are minimized by allocating ESS units. They also modeled uncertain parameters associated with their model by sequential Monte Carlo simulation (MCS) and probabilistic load flow.

The authors in [6] minimized the cost in the ESS allocation problem that would also maintain distribution network voltages within permissible ranges. The authors in [7] investigated the impact of a centralized ESS on daily energy generation costs and analyzed the hourly reactive power of ESS when ESS is connected to P-V or P-Q buses. A hybrid system which included ESS, photovoltaic (PV), and wind units was investigated in [8] using the genetic algorithm (GA) for minimizing the life cycle cost, emission, and dumped energy. The authors in [9] allocated the ESS within distribution networks for reducing energy loss, load curtailment, and energy supply cost.

A hybrid ESS allocation problem was presented in [10] considering multi-step multi-price demand response programs. Another hybrid PV-ESS capacity allocation problem is presented in [18] wherein the authors used a price-based control strategy to improve the capacity allocation model. The ESS allocation along with WPG was represented in

[11–15]. The optimal ESS allocation in a WPG-penetrated system was presented in [11], which assessed the impact of WPG on the ESS allocation problem. In [12], the authors demonstrated that pumped hydro storage would be allocated on the demand side while flywheels are assigned to wind generation units. In [13], it is shown that ESS units can reduce energy trading risks in distribution companies (DISCOs).

Also, the authors in [14] addressed the ESS allocation problem in a multi-agent power market where the agents are persuaded to use ESS to maximize their payoffs. Same subject studied in [16], wherein authors tried to manage the transmission network by using optimal allocation of ESS as ready-to-respond units. The units are price-taker and the circuit breakers reliability are also considered in their cost function model. Reference [17] represented an operation model wherein the WPGs and ESSs are coordinated and transmission switching (TS) [32] is used to reduce the operation cost of the network. In [19] authors investigated the optimal placement of ESSs for supporting WPGs with doubly fed induction generator (DFIG) as fast response units for frequency reserve. In [20], both the correction effect among WT and the allocation of ESS in WT integrated power systems are concerned and a new hybrid optimization algorithm is represented to allocate the price-taker ESSs. In [21], authors went through two major steps to allocate the renewable energy sources including WTs and ESS in partitioned transmission network. They assessed the portioned with the most applicability of hosting DERs.

Although previous studies have addressed the ESS allocation, the remaining challenges in the allocation problem can be summarized as follows:

- (1) The ESS aging and charging/discharging efficiency will have a significant impact on power system operations.
- (2) The optimal number of ESS units will be affected by the ESS installation and operation and maintenance costs.
- (3) The variability of WPG and its correlation among local wind generation units would need to be addressed accurately.
- (4) The allocation of WPG and ESS, considering discrete uncertainties such as contingency and congestion of the lines and generation units as the power system’s critical occasions, which might be due to any reason or faults.

To the best of authors’ knowledge, none of the previous works have provided an effective model for optimal congestion based price-maker wind-storage unit as a market participant. In this regard, this paper proposes an effective model for the optimal allocation problem of a price-maker unit in transmission-constraint LMP-based electricity market.

It is noteworthy that any generation/consumption unit that is willing to participate in the market can be a price-maker [22,23] or price-taker [24]. In [24], the author explicitly noted that congestion effect of the transmission lines could significantly impact the performance of a market player. Ignoring such issue, would make the allocation problem no longer to be optimal. With this mind, the negative impact of the congestion of the transmission lines as unpredictable events can be prevented.

Hence, the main contributions of this paper with respect to the previous work by authors in[33] and other literature in the area can be summarized as follows:

- The congestion based optimal allocation problem of a price-maker wind-storage unit is aimed in this paper. The main focus is on minimizing the negative impact of the congestion of the transmission

lines on the operation of the wind-storage unit as a price-maker market participant.

- A max–min-max tri-level optimization procedure is pursued in this paper to satisfy three objective functions. Firstly, the profit maximization of the market participant should be guaranteed. Secondly, the minimization cost of the independent system operator (ISO) needs to be satisfied. It’s been also attempted to consider the robust operation of the WTs, which would be the third objective function of the proposed model.
- A transmission switching integrated robust chance-constraint (TSIRC) approach is used to robust the power output of the WTs against the uncertainties as well as to increase the contribution of the WTs-as a zero operation cost power unit-in the operation problem to decrease the ISO cost.
- Uncertainty assessment based on unscented transform (UT) method to model the correlated uncertainties of WTs due to the wind speed variations.

The rest of this paper is organized as follows: Section 2 is dedicated to the proposed tri-level model. Section 3 describes the uncertainty modelling based on UT method. Results are discussed in section 4 and finally the work is concluded in section 5.

## 2. Mathematical formulations: tri-level optimization framework

In this section, the proposed tri-level model is defined. The schematic of the model can be seen in Fig. 1. First level shows the profit of the wind generation unit and the ESS obtained by participating in the market. Second level is the market clearing mechanism and the dispatch cost of the system operation needs to be minimized from the perspective of the ISO. The third level represents the TSRIC where the maximum tolerable value of the power output of the WTs needs to be determined. The first level and second level are inevitably connected since the profit assessment of the wind-storage unit needs the bidding prices of both the ESS and wind units obtained from the second level. In this regard, they can be represented as a bilevel model using the Karush-Kuhn-Tucker (KKT) conditions [25].

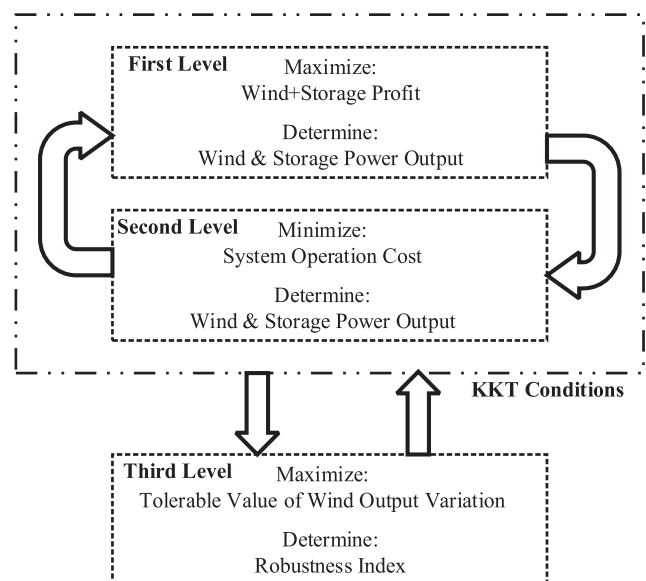

Fig. 1. Tri-level model framework.

### 2.1. First level

The objective function and constraints related to the first level are expressed as follows:

$$f_1 = \sum_{t \in \Omega^T} \left( \sum_{w \in \Omega^{WT}} (N_{WT}^t \times P_{WT}^t) + \sum_{e \in \Omega^{ESS}} (N_e^t \times P_e^t) \right) \quad (1)$$

$$r_e^{dch,t} + r_e^{ch,t} \leq 1 \quad e \in \Omega^{ESS}, t \in \Omega^T \quad (2)$$

$$P_e^t = P_e^{t-1} - r_e^{dch,t} \times \left( \frac{1}{\eta^{dch}} \times P_e^{dch,t-1} \times \Delta t \right) + r_e^{ch,t} \times (\eta^{ch} \times P_e^{ch,t-1} \times \Delta t) \quad e \in \Omega^{ESS}, t \in \Omega^T \quad (3)$$

$$0 \leq P_e^{ch,t} \leq \bar{P}_e^{ch,t} \times r_e^{ch,t} \quad e \in \Omega^{ESS}, t \in \Omega^T \quad (4)$$

$$0 \leq P_e^{dch,t} \leq \bar{P}_e^{dch,t} \times r_e^{dch,t} \quad e \in \Omega^{ESS}, t \in \Omega^T \quad (5)$$

$$\underline{E}_e \leq E_e^t \leq \bar{E}_e \quad e \in \Omega^{ESS}, t \in \Omega^T \quad (6)$$

$$0 \leq P_w^t \leq \bar{P}_w^t \quad w \in \Omega^{WT}, t \in \Omega^T \quad (7)$$

The profit maximization of the wind and ESS units is represented in (1). Constraint (2) expresses that the ESS unit is not allowed being charged/discharged, simultaneously. The hourly available ESS's power (3), charging power bid of the ESS (4), discharging power bid of the ESS (5) and the ESS's energy level limit (6) are required for the proper operation of the ESS unit. The constraint (7) shows the hourly power bidding of the WT in the operation problem.

### 2.2. Second level

The objective function and constraints related to this subsection are represented in the following.

$$f_2(X) = \sum_{t \in \Omega^T} \left[ \begin{aligned} & \sum_{g \in \Omega^g} \left[ (\delta_g^t \times P_g^t) + SU_g^t(v_g^t) + SD_g^t(w_g^t) \right] \\ & - \sum_{L \in \Omega^L} (\alpha_L^t \times P_L^t) + \sum_{w \in \Omega^{WT}} (\varphi_w^t \times P_w^t) + \sum_{e \in \Omega^{ESS}} (\varpi_e^t \times P_e^t) \end{aligned} \right] \quad (8)$$

$$P_g^t - P_L^t + P_w^t + P_e^t = \sum_{Ln \in \Omega^{Ln}} P_{Ln}^t \quad g \in \Omega^g, L \in \Omega^L, w \in \Omega^{WT}, e \in \Omega^{ESS}, t \in \Omega^T \quad (9)$$

$$\underline{P}_g^t u_g^t u_{g,s} \leq P_g^t \leq \bar{P}_g^t u_g^t u_{g,s} \quad g \in \Omega^g, t \in \Omega^T \quad (10)$$

$$v_g^t - w_g^t = u_g^t - u_g^{t-1} \quad g \in \Omega^g, t \in \Omega^T \quad (11)$$

$$\sum_{t'=t-UT_g+1}^t v_g^{t'} \leq u_g^t, \quad g \in \Omega^g, t \in \{\bar{T}_g, \dots, T\} \quad (12)$$

$$\sum_{t'=t-DT_g+1}^t w_g^{t'} \leq 1 - u_g^t, \quad g \in \Omega^g, t \in \{\underline{T}_g, \dots, T\} \quad (13)$$

$$P_g^t - P_g^{t-1} \leq \bar{R}_g u_g^{t-1} + \bar{P}_g^t v_g^t \quad g \in \Omega^g, t \in \Omega^T \quad (14)$$

$$P_g^{t-1} - P_g^t \leq \bar{R}_g u_g^t + \bar{P}_g^t w_g^t \quad g \in \Omega^g, t \in \Omega^T \quad (15)$$

$$\underline{P}_L \leq P_L^t \leq \bar{P}_L^t \quad L \in \Omega^L, t \in \Omega^T \quad (16)$$

$$-\bar{P}_e^{dch,t} \leq P_e^t \leq \bar{P}_e^{ch,t} \quad e \in \Omega^{ESS}, t \in \Omega^T \quad (17)$$

$$\underline{P}_w \leq P_w^t \leq \bar{P}_w^t \quad w \in \Omega^{WT}, t \in \Omega^T \quad (18)$$

$$(-\bar{P}_{Ln,t} + P_{Ln,s}^{cong,cong}) z_{Ln,t} z_{Ln,s}^{cont} \leq P_{Ln}^t \leq (\bar{P}_{Ln,t} - P_{Ln,s}^{cong,cong}) z_{Ln,t} z_{Ln,s}^{cont} \quad Ln \in \Omega^{Ln}, t \in \Omega^T, s \in \Omega^S \quad (19)$$

where the control variables of the primal problem (8) are  $\{X = P_g^t, P_L^t, P_w^t, P_e^t, \theta_i^t\}$ . Equation (8) shows the economic dispatch problem where it defines the power output of the generation units. The power balance equation (9) guarantees the system's demands supplement. The power output of the generators is limited by (10). It is worth mentioning that the binary variable  $u_g$  shows the outage of the generation unit due to an unforeseeable cause.

Constraints (11)–(13) represent the on/off time of the generators. Constraints (14) and (15) are the ramp up and ramp down of the generators. Constraint (16) expresses the limit of dispatchable loads. Constraints (17) and (18) show the limits of the power output of the ESSs and WTs, respectively.

Constraint (19) reveals that due to the technical limitations, the power value through the transmission lines have to be restricted. In this regard, the power injections through the lines are limited within their maximum and minimum capacities. There are some points hereby need to be explained.

Firstly, the connected or not connected status of the power lines need to be also modelled. It is worth mentioning that in this paper, the *contingency* means any unpredictable event causes the outage of the power generation units or the power lines during some specific circumstances. Such issue has been modelled by  $z_{Ln,s}^{cont}$  and defines a set of scenarios with specific probabilities imposed to the problem. If  $z_{Ln,s}^{cont} = 0$  then the power line  $Ln$  is out-of-service and the constraint (19) will no longer be affective. Similar justification would be valid for variable  $z_{Ln,t}$ . However, since the binary variable  $z_{Ln,t}$  implies the TS method, the proposed variable is under control of the ISO as an effective tool to reduce the total cost of operation. As it was mentioned before, this paper focuses on the congestion based allocation of the wind and storage units.

Hence, it would be well worth if the congestion effect being modelled. On the other hand, the power lines are not able to pass any additional power and their nominal capacity is filled entirely. To model such a thing, we can reduce the nominal capacity of the lines for a specific value to force the lines to be congested in the power flow process. Constraint (19) models such definition which basically is the power lines constraint. Constraint (19) can be changed in different conditions. For the first condition let us assume power line  $Ln$  is not available due to an unpredictable event (a contingency event) which is defined by scenario  $s$  for the problem. In this regard, binary variable  $z_{Ln,s}^{cont}$  gets zero value and constraint (19) will be neglected. Indeed, we do not need this constraint since the power line is out-of-service and there is no need to be considered in the power flow problem. The same thing happens if the line is forced to be switched off by the TS method. In this case, binary variable  $z_{Ln,t}$  gets zero value and makes both upper and lower bounds of the constraint (19) zero. For the third condition, assume both  $z_{Ln,t}$  and  $z_{Ln,s}^{cont}$  are 1 and the line is not congested ( $z_{Ln,s}^{cong} = 0$ ). In this case, constraint (19) is transformed into  $-\bar{P}_{Ln,t} \leq P_{Ln}^t \leq \bar{P}_{Ln,t}$ . This constraint indicates a completely normal condition, lines are able to pass the entire scheduled power values they are expected to pass and we have a healthy power network. The fourth condition and the one which makes all the differences in the condition when the lines are congested ( $z_{Ln,s}^{cong} = 1$ ) and constraint (19) will be changed to  $-\bar{P}_{Ln,t} + P_{Ln,s}^{cong} \leq P_{Ln}^t \leq \bar{P}_{Ln,t} - P_{Ln,s}^{cong}$ .  $P_{Ln,s}^{cong}$  is a parameter and a predefined value which is imposed to the problem through scenario  $s$ . as can be seen,  $P_{Ln,s}^{cong}$  will reduce the nominal capacity of the power lines to a specific value. This helps us to consider congestion situations in the modelling automatically by the mathematical modelling and through a series of realizations. Constraint (20) expresses the value of the injected power through the lines and the constraint (21) limits the angle of the bus at each timespan. As it was mentioned before, the trilevel problem can be transformed into bilevel

problem using KKT condition. Utilizing the lagrangian function (22), KKT conditions and holding the strong duality over the primal problem (constraint (8)), the resulted problem can be considered as follows:

$$P_{i,j,Ln}^t = B_{ij}(\theta_i^t - \theta_j^t) \quad Ln \in \Omega^{Ln}, t \in \Omega^T, (i,j) \in \Omega^{bus} \quad (20)$$

$$-\bar{\theta}_i \leq \theta_i^t \leq \bar{\theta}_i \quad t \in \Omega^T, i \in \Omega^{bus} \quad (21)$$

$$\begin{aligned} L(X, \aleph_i, \varepsilon_g, \hat{\varepsilon}_g, \mu_L, \hat{\mu}_L, \gamma_{Ln}, \hat{\gamma}_{Ln}, \xi, \hat{\xi}) = F(X) + \\ \varepsilon_g (P_g^t - P_g^t u_g^t u_{g,s}^t) + \hat{\varepsilon}_g (\bar{P}_g^t u_g^t u_{g,s}^t - P_g^t) + \mu_L (P_L^t - \bar{P}_L^t) + \\ \hat{\mu}_L (\bar{P}_L^t - P_L^t) + \gamma_{Ln} (P_{Ln}^t - [(-\bar{P}_{Ln,t} + P_{Ln,s}^{cong} z_{Ln,t}^{cont})]) + \\ \hat{\gamma}_{Ln} ([(\bar{P}_{Ln} - P_{Ln,s}^{cong} z_{Ln,t}^{cont}) - P_{Ln}^t]) + \xi (P_w^t - \bar{P}_w^t) + \\ \hat{\xi} (\bar{P}_w^t - P_w^t) + \aleph_i (P_g^t - P_L^t + P_w^t + P_e^t - \sum_{Ln \in \Omega^{Ln}} P_{Ln}^t) \end{aligned} \quad (22)$$

$$\begin{aligned} \hat{f}_2(\bar{X}) = \sum_{t \in \Omega^T} \left( \sum_{w \in \Omega^{WT}} (\aleph_w^t \times P_w^t) + \sum_{e \in \Omega^{ESS}} (\aleph_e^t \times P_e^t) \right) = \\ \sum_{t \in \Omega^T} \left( \begin{aligned} & - \sum_{g \in \Omega^g} (\delta_g^t \times P_g^t) + \sum_{L \in \Omega^L} (\alpha_L^t \times P_L^t) + \sum_{g \in \Omega^g} (\varepsilon_g^t \times P_g^t) \\ & - \sum_{g \in \Omega^g} (\hat{\varepsilon}_g^t \times \bar{P}_g^t) + \sum_{L \in \Omega^L} (\mu_L^t \times P_L^t) - \sum_{L \in \Omega^L} (\hat{\mu}_L^t \times \bar{P}_L^t) \\ & - \sum_{Ln \in \Omega^{Ln}} (\gamma_{Ln}^t \times P_{Ln}^t) - \sum_{Ln \in \Omega^{Ln}} (\hat{\gamma}_{Ln}^t \times P_{Ln}^t) \end{aligned} \right) \quad (23) \\ s.t. \end{aligned}$$

$$(2) - (7), (9) - (21)$$

$$\delta_g^t - \aleph_g^t - \varepsilon_g^t + \hat{\varepsilon}_g^t = 0 \quad g \in \Omega^g, t \in \Omega^T \quad (24)$$

$$-\alpha_L^t + \aleph_L^t - \mu_L^t + \hat{\mu}_L^t = 0 \quad L \in \Omega^L, t \in \Omega^T \quad (25)$$

$$\aleph_e^t - \aleph_e^t - \psi_e^t + \hat{\psi}_e^t = 0 \quad e \in \Omega^{ESS}, t \in \Omega^T \quad (26)$$

$$\varphi_w^t - \aleph_w^t - \xi_w^t + \hat{\xi}_w^t = 0 \quad w \in \Omega^{WT}, t \in \Omega^T \quad (27)$$

$$\varepsilon_g^t \leq (1 - I\varepsilon_g^t)M \quad g \in \Omega^g, t \in \Omega^T \quad (28)$$

$$P_g^t - \bar{P}_g^t \leq I\varepsilon_g^t M \quad g \in \Omega^g, t \in \Omega^T \quad (29)$$

$$\hat{\varepsilon}_g^t \leq (1 - I\hat{\varepsilon}_g^t)M \quad g \in \Omega^g, t \in \Omega^T \quad (30)$$

$$\bar{P}_g^t - P_g^t \leq I\hat{\varepsilon}_g^t M \quad g \in \Omega^g, t \in \Omega^T \quad (31)$$

$$\mu_L^t \leq (1 - I\mu_L^t)M \quad L \in \Omega^L, t \in \Omega^T \quad (32)$$

$$P_L^t - \bar{P}_L^t \leq I\mu_L^t M \quad L \in \Omega^L, t \in \Omega^T \quad (33)$$

$$\hat{\mu}_L^t \leq (1 - I\hat{\mu}_L^t)M \quad L \in \Omega^L, t \in \Omega^T \quad (34)$$

$$\bar{P}_L^t - P_L^t \leq I\hat{\mu}_L^t M \quad L \in \Omega^L, t \in \Omega^T \quad (35)$$

$$\psi_e^t \leq (1 - I\psi_e^t)M \quad e \in \Omega^{ESS}, t \in \Omega^T \quad (36)$$

$$P_e^t - \bar{P}_e^t \leq I\psi_e^t M \quad e \in \Omega^{ESS}, t \in \Omega^T \quad (37)$$

$$\hat{\psi}_e^t \leq (1 - I\hat{\psi}_e^t)M \quad e \in \Omega^{ESS}, t \in \Omega^T \quad (38)$$

$$\bar{P}_e^t - P_e^t \leq I\hat{\psi}_e^t M \quad e \in \Omega^{ESS}, t \in \Omega^T \quad (39)$$

$$\xi_w^t \leq (1 - I\xi_w^t)M \quad w \in \Omega^{WT}, t \in \Omega^T \quad (40)$$

$$P_w^t - \bar{P}_w^t \leq I\xi_w^t M \quad w \in \Omega^{WT}, t \in \Omega^T \quad (41)$$

$$\hat{\xi}_w^t \leq (1 - I\hat{\xi}_w^t)M \quad w \in \Omega^{WT}, t \in \Omega^T \quad (42)$$

$$\bar{P}_w^t - P_w^t \leq I\hat{\xi}_w^t M \quad w \in \Omega^{WT}, t \in \Omega^T \quad (43)$$

$$\gamma_{Ln}^t \leq (1 - I\gamma_{Ln}^t)M \quad Ln \in \Omega^{Ln}, t \in \Omega^T \quad (44)$$

$$P_{Ln}^t - \bar{P}_{Ln}^t \leq I\gamma_{Ln}^t M \quad Ln \in \Omega^{Ln}, t \in \Omega^T \quad (45)$$

$$\hat{\gamma}_{Ln}^t \leq (1 - I\hat{\gamma}_{Ln}^t)M \quad Ln \in \Omega^{Ln}, t \in \Omega^T \quad (46)$$

$$\bar{P}_{Ln}^t - P_{Ln}^t \leq I\hat{\gamma}_{Ln}^t M \quad Ln \in \Omega^{Ln}, t \in \Omega^T \quad (47)$$

$$\varepsilon_g^t \geq 0, \hat{\varepsilon}_g^t \geq 0, \mu_L^t \geq 0, \hat{\mu}_L^t \geq 0, \gamma_{Ln}^t \geq 0, \hat{\gamma}_{Ln}^t \geq 0, \xi_w^t \geq 0, \hat{\xi}_w^t \geq 0 \quad (48)$$

$$I\varepsilon_g^t, I\hat{\varepsilon}_g^t, I\mu_L^t, I\hat{\mu}_L^t, I\xi_w^t, I\hat{\xi}_w^t, I\gamma_{Ln}^t, I\hat{\gamma}_{Ln}^t \in \{0, 1\} \quad (49)$$

### 2.3. Third level: TSIRC method

The TSIRC definition starts with the interval based robust approach (IBRA) method where the definition of which is to maximize the most possible power output variation of the WTs insofar as the technical constraints of the system being regarded. The basic formulation of the IBRA is represented as follows:

$$\max \beta \quad (50)$$

$$\bar{P}_w^t, \underline{P}_w^t = (1 \pm \beta)\bar{P}_{f,w}^t, \quad \forall \beta \in [\underline{\beta}, \bar{\beta}] \quad (51)$$

$$\hat{f}_2 \leq \bar{C}, \quad \forall \beta \in [\underline{\beta}, \bar{\beta}] \quad (52)$$

$$(2) - (7), (9) - (21), (32) - (58) \quad (53)$$

The objective function (50) maximizes the power output variation of the WTs considering constraints (42)-(44). The power output of the WTs varies between  $(1 - \beta)\bar{P}_w^t$  to  $(1 + \beta)P_{f,st}$ . Constraint (52) expresses that the total cost of operation should not exceed a predefined value. Such value depends on the risk-taking manner of the decision maker. As a matter of fact, the lower risk is taken, the more cost is incurred and the system will be more sustainable. Ignoring the system congestions as discrete uncertainties of the problem is the main drawback of IBRA. In this regard, the interval based robust chance constraint (IBRCC) method introduced to model the DUs associated with the contingency events [25]. In this paper, the TSIRC method is introduced with the aim of considering both contingency and congestion effects as undeniable uncertain occurrences. Such DUs have been modelled as probabilistic realizations.

With this in mind, the TSIRC method starts with the following inequality which is the chance constraint definition of the constraints (51) and (52).

$$Pr \left\{ \begin{aligned} \bar{P}_w^t, \underline{P}_w^t = (1 \pm \beta)\bar{P}_{f,w}^t \\ \hat{f}_2 \leq \bar{C} \end{aligned} \right\} \geq (1 - \eta_1), (1 - \eta_2) \quad (54)$$

As it was mentioned before, the contingency and congestion are defined as a set of scenarios. Hence, the probabilities of (51) and (52) have been one-sidedly bounded to  $1 - \eta_1$  and  $1 - \eta_2$  where the  $\eta_1$  and  $\eta_2$  are the risk of considering inappropriate scenarios for the contingency and congestion, respectively. The formulation of the TSIRC can be represented as follows:

$$\max \beta \tag{55}$$

$$\left( \overline{P}_w, \underline{P}_w - (1 \pm \beta) \overline{P}_{f,w} \right) \cdot (z_s) = 0 \quad w \in \Omega^{WT}, t \in \Omega^T, s \in \Omega^S \tag{56}$$

$$(\widehat{f}_2 - \overline{C}) \cdot (z_s) \leq 0 \quad w \in \Omega^{WT}, t \in \Omega^T, s \in \Omega^S \tag{57}$$

$$\sum_s pr_1(Ln, s) \cdot (z_{Ln,t}^{cong} z_{Ln,t}^{cont}) - z_{Ln,t} \cdot \eta_1 \leq 0 \quad Ln \in \Omega^{Ln}, t \in \Omega^T, s \in \Omega^S \tag{58}$$

$$\sum_s pr_2(Ln, s) \cdot (z_{Ln,t}^{cong} z_{Ln,t}^{cont}) - z_{Ln,t} \cdot \eta_2 \leq 0 \quad Ln \in \Omega^{Ln}, t \in \Omega^T, s \in \Omega^S \tag{59}$$

$$z_s = (z_{Ln,t}^{cong} + z_{Ln,t}^{cont}) \cdot z_{Ln,t} \quad Ln \in \Omega^{Ln}, t \in \Omega^T, s \in \Omega^S \tag{60}$$

The binary variable  $z_s$  shows whether a congestion or contingency of the transmission lines for the scenario  $s$  is considered or not. Constraints (56) and (57) are eliminated once  $z_s = 0$ . The constraints (58) and (59) restrict the number of plausible scenarios which will simplify the problem. It is worth mentioning that  $z_{Ln,t}$  shows the open or closed status of the power lines [27]. In this regard if  $z_{Ln,t} = 0$ , the constraints (58) and (59) are ignored. In fact, the TS will increase the power output of the WTs and the system's robustness during extreme events which are represented by  $s$  number of feasible scenarios. The overall optimization problem can be represented as follows:

$$\max \beta \tag{62}$$

$$(2) - (7), (9 - 21), (32 - 58), (65 - 69). \tag{62}$$

The above formulation is a mixed-integer linear programming (MILP) problem, which can be solved by using any MILP solver.

### 3. Uncertainty modeling based on UT method

Recently, UT method has drawn attentions as a potential method for capturing uncertainty of the elements. [28] states the UT method has shown to be an accurate and fast method specifically in correlated environment where the uncertain variables have an impact on the other through a correlation index. Hence, the UT method is utilized to handle both the both correlated and non-correlated uncertainty variables.

The process begins with considering a hypothetical nonlinear function  $\beta = f(\alpha)$ . The  $\alpha$  and  $\beta$  represent the input and output vectors of the stochastic variables in the problem. It is assumed that the stochastic vector  $\alpha$  has  $m$  uncertain parameters with a mean value of  $W_\alpha$  and covariance of  $Q_\alpha$ . Based on [28],  $Q_\alpha$  is a matrix in which the uncertain parameters are embedded symmetrically and correlated parameters are the non-symmetric elements of the matrix. For  $m$  number of uncertain parameters,  $2m + 1$  points need to be generated and for each stochastic variable, the variance and covariance matrices are calculated in each stage. The following steps explains the whole process of UT performance. All formulations are drawn from the reference [34] and interested readers are referred to the reference [28] for more information.

**Step 1:** calculating  $2m + 1$  samples of the uncertain inputs.

**Step 2:** calculating the weighting factors associated with each sample point.

**Step 3:** calculating  $2m + 1$  output samples associated with  $2m + 1$  input samples by using the proposed nonlinear function.

**Step 4:** calculating the covariance  $Q_\beta$  and mean value of output  $2m + 1$  samples  $W_\alpha$ .

### 4. Simulation results

This section examines the performance of the proposed model on an IEEE-24 bus modified test system [30]. In this regard, 6 power sources including 3 WTs (each one is 220 kW) [15] and 3 ESSs (each one is 110 kW) [32] are considered for the assessment of effectiveness of the model. The WT is operated on the basis of the wind speed in [31]. Simulations were performed using a PC with 4 GHz processor, core i7 and 16 GB of RAM and implemented in GAMS and MATLAB software. Table 1 shows the bus and demand data of the 24-bus test system. As it was mentioned, in the proposed tri-level optimization problem, the first and second levels can be transformed into a single-level optimization using KKT conditions and is represented from the ISO viewpoint, which is also expressed in [28]. The third level is also defined from the perspective of the ISO. In this regard, the final optimization problem is solved from the ISO viewpoint.

In order to evaluate different aspects of the work, 3 different cases are considered as follows:

- (1) Case I: Impact of congestion on allocation problem of the price-maker WTs-ESSs unit
- (2) Case II: Performance evaluation of the TSIRC approach in allocation problem
- (3) Case III: Impact of uncertainty in allocation problem

Each one of the cases will be discussed in the following.

**Table 1**  
The bus and demand parameters of the network.

Bus number	Vmin	Vmax	Pd (MW)	Qd (MVAR)
1	0.95	1.05	108	22
2	0.95	1.05	97	20
3	0.95	1.05	180	37
4	0.95	1.05	74	15
5	0.95	1.05	71	14
6	0.95	1.05	136	28
7	0.95	1.05	125	25
8	0.95	1.05	171	35
9	0.95	1.05	175	36
10	0.95	1.05	195	40
11	0.95	1.05	0	0
12	0.95	1.05	0	0
13	0.95	1.05	265	54
14	0.95	1.05	194	39
15	0.95	1.05	317	64
16	0.95	1.05	100	20
17	0.95	1.05	0	0
18	0.95	1.05	333	68
19	0.95	1.05	181	37
20	0.95	1.05	128	26
21	0.95	1.05	0	0
22	0.95	1.05	0	0
23	0.95	1.05	0	0
24	0.95	1.05	0	0

4.1. Case I: Impact of congestion on allocation problem of the price-maker unit

In this case, it is tried to achieve the impact of the congestion effect on the optimal allocation of the studied price-maker unit. Worth a mention is that in this paper, the congestion refers to an unpredictable occasion which leads the transmission lines' capacities being deviated for a certain value from their nominal capacity within a timespan. Different congestion occasions are considered in the form of scenarios in this case. By using the optimization method, the optimal location of the WT and ESSs are considered.

Fig. 2 depicts the optimal location of the energy sources considering non-congested (a) and congested occasions (b).

As can be seen the optimal place of the units are varied during the congestion situation. The red-colored lines indicate the congested lines shown in Fig. 2. Since, the proposed model defines the performance of a price-maker unit, it is more tended to find the locations through which the profit of the proposed price-maker unit can be maximized and are near to the congestion lines from the geographical point of view.

4.2. Case II: Performance evaluation of the TSIRC approach in allocation problem

As it was mentioned before, a TSIRC approach is proposed in this paper aiming to improve the effectiveness of the model.

Fig. 3 shows the LMP of the buses. As can be seen in Fig. 3(a) and without execution of the TSIRC, the LMP of the buses have deviated from their nominal values at  $t = 2$  and 13. This condition is varied when the TSIRC is applied to the model and the buses are mostly deviated at  $t = 7$  and 8. This explicitly shows the effect of the TSIRC on the LMP of the buses. One can conclude that the proposed approach has managed the congestion of the lines aiming to boost the profit of the studied price-maker WT-ESS unit. The effectiveness of the TSIRC can be discussed in two main distinct viewpoints: (1) the bidding/offering of the energy, (2) bidding/offering of the price.

Fig. 4 shows the ESSs energy exchange without (a) and with (b) the TSIRC approach. It can be seen that considering the TSIRC method, the ESSs have been more inclined to be charged (negative values) within the off-peak hours and discharged (positive values) during peak hours. In other words, the ESSs are more preferred to be charged during the hours that the energy prices are low which can be obviously seen during the charging hours  $t = 14-15$  which are shifted to the other hours of the day.

Fig. 5 shows the power output of the WTs. one can see that the power output of the WTs are increased considering the TSIRC approach. It is also worth mentioning that the TSIRC approach affected the bidding/offering prices of the WTs and ESSs. Prior to explain such claim, it should be mentioned that the profit increment surely relies on the increase of price and energy of the price-maker participant. Besides, the bidding/offering price of the units are obtained based on the LMP of the buses which the WTs and ESSs are connected to. Fig. 6 shows the bidding/offering prices of the BESSs without TSIRC (a) and with TSIRC (b) method.

Firstly, it can be seen that optimal locations of the ESSs are changed from buses 5, 18 and 23 to buses 7, 17 and 23. It is evident that using the TSIRC, optimal bidding/offering prices of the ESS which is connected to bus 21 is significantly increased which starts from 40\$ and has been stabilized to the end of the day. The same behavior can be seen during  $t = 20-22$  when the ESS which is connected to bus 17 increased its bidding/offering price almost 3 times higher than the one offered without TSIRC method within the same hours.

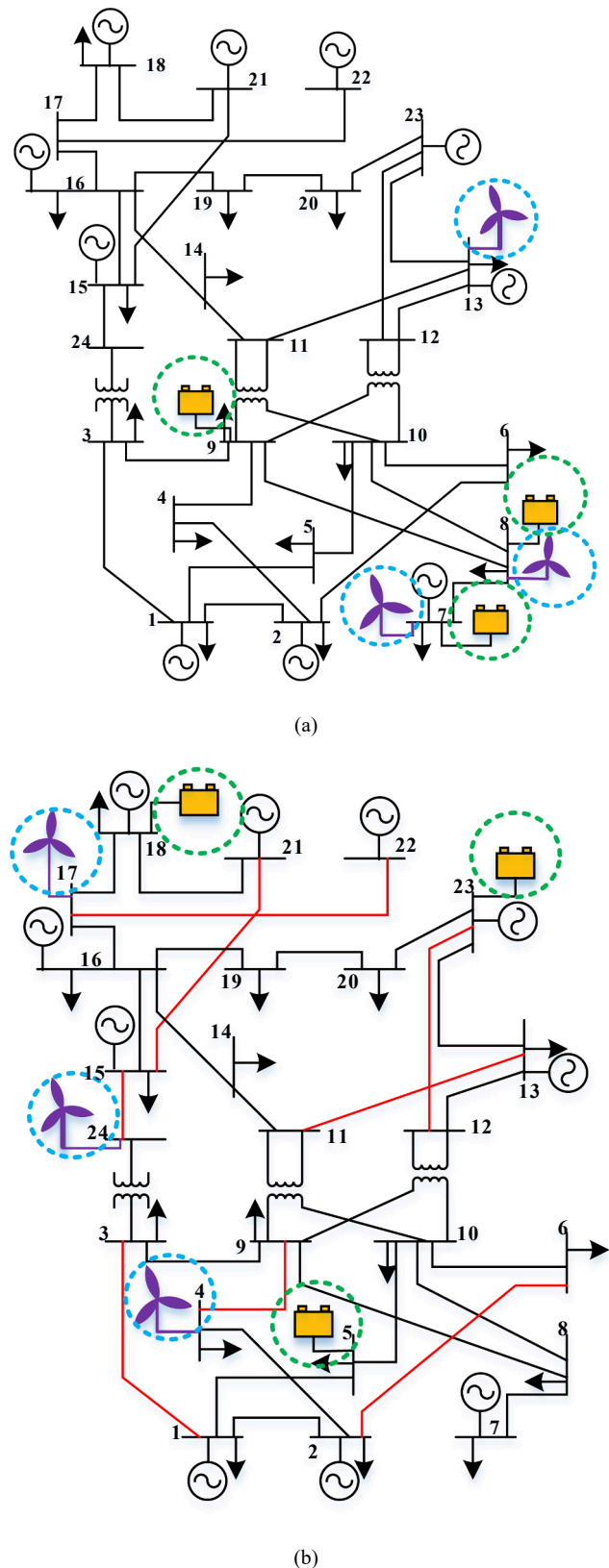

Fig. 2. Locations of ESSs and WTs: (a) without congestion (b) with congestion.

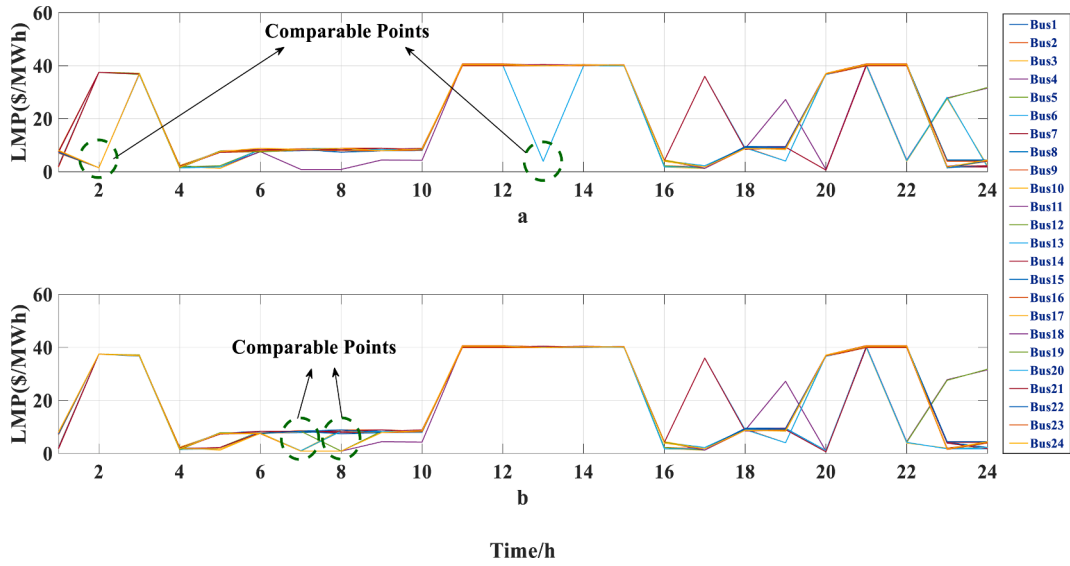

Fig. 3. LMP of the buses: (a) without TSIRC (b) with TSIRC.

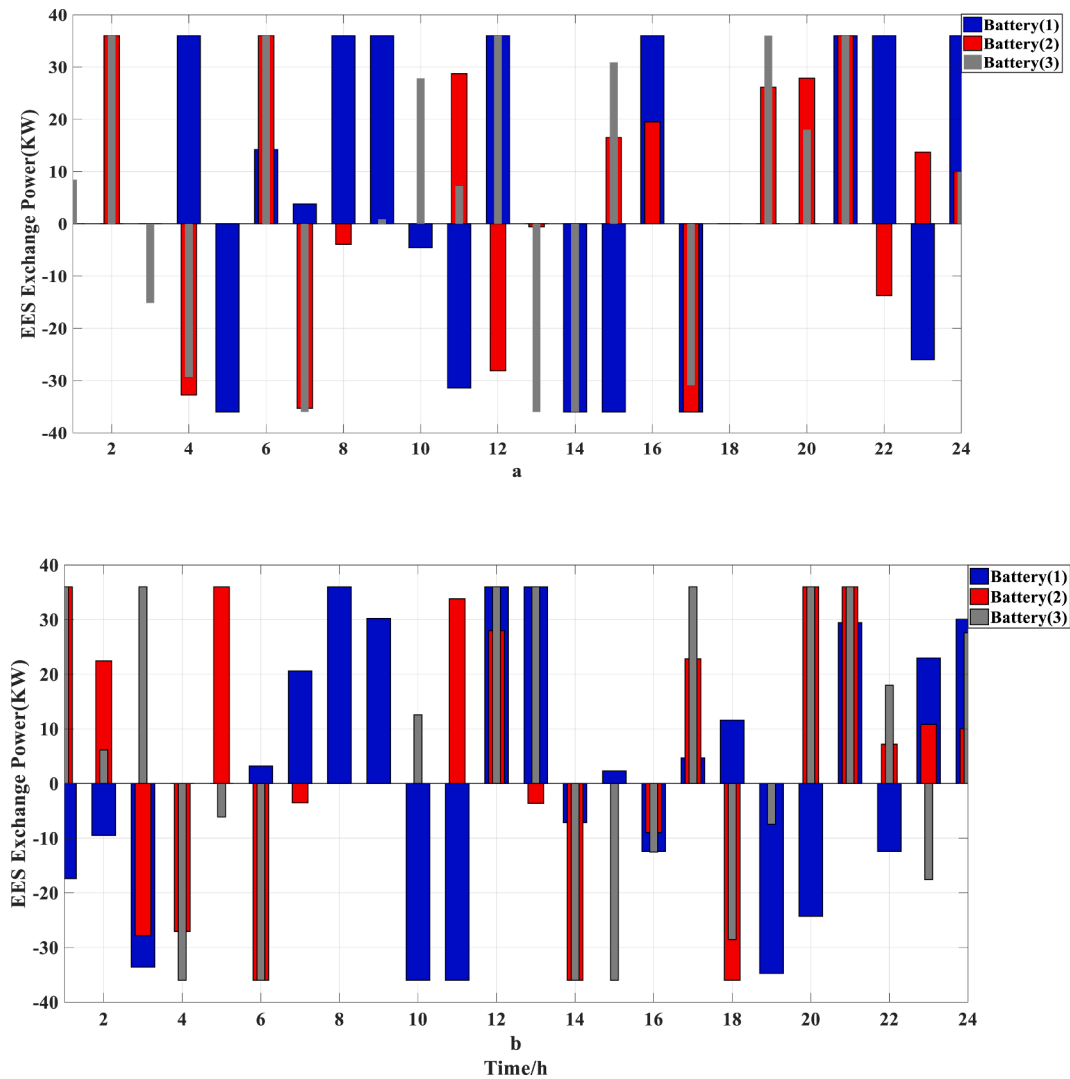

Fig. 4. The ESSs power exchange: (a) without TSIRC (b) with TSIRC.

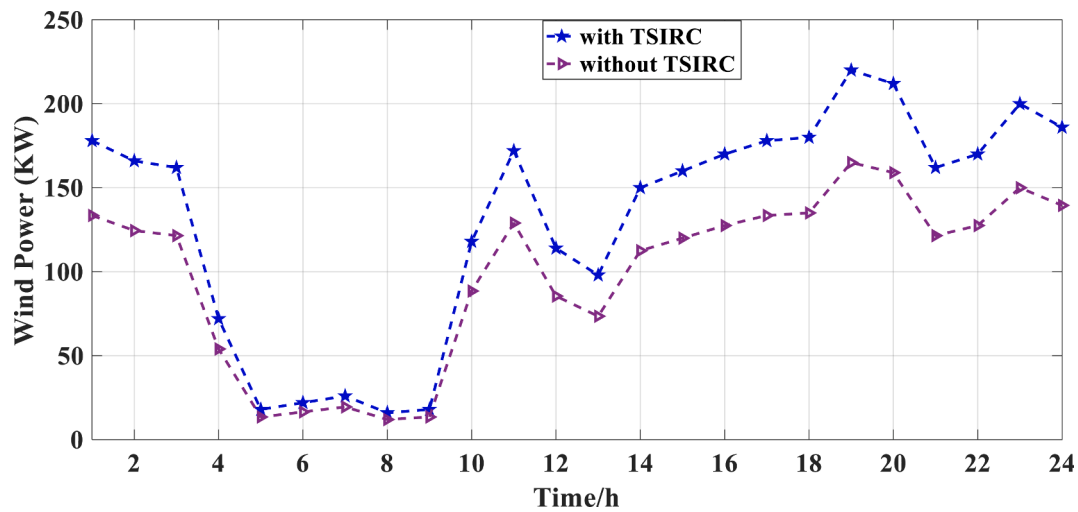

Fig. 5. The power output of the WTs.

In Fig. 7, the bidding/offering prices of the WTs are shown without considering the TSIRC (a) and considering the TSIRC (b). The optimal locations of the WTs are also varied from buses 4, 17 and 24 to buses 6, 7 and 8. The same definitions are compatible for the WTs' bidding/offering prices where it is more preferred to increase the bidding/offering prices WPPs (1) and (3) from almost 2 \$ to 8\$. Also, the convergence characteristic of the proposed algorithm has been compared with respect to other methods, i.e., FA, GA, and BF, in Fig. 8.

On average, one can say that the bidding/offering prices on WPP (3) have been increased almost 37.7% over the day. One can conclude that in addition to the increase of the power and price bidding values of the WTs and ESSs, the proposed model has led the optimal places of the WTs and ESSs to be changed aiming to increase the price-maker unit's profit during the congestion circumstances.

#### 4.3. Case III: Impact of uncertainty in allocation problem

As it was mentioned before, another case pursued in this paper is how the uncertainty of the renewable sources affect the performance of the price-maker WT and ESS units. Results of different case studies including the basic and proposed model in both normal and critical mode and the impact of uncertainty on the proposed model are provided in Table 1. The uncertainty in the studies are either continues such as wind speed and sunlight or discrete such as line or generator outage [26]. The wind speed uncertainty and the correlation effect among WTs are modelled in this work.

Table 2 shows a comparison between different analyses of the work. In this regard, optimal locations of the ESSs and WTs as well as their bidding values are provided considering five different study cases. As can be seen, the locations of the ESSs are changed from buses 6, 7 and 20

in the proposed model to buses 1, 7 and 8 due to the uncertainty factors. This is compatible with locations of the WTs. Also, the bidding values are varied and decreased by almost 55 %. All these explanations show the inevitable impact of the uncertainty factors on optimal solutions of the problem.

In order to clarify the effectiveness of the studied method in the allocation problem, the convergence speed of the BPSO algorithm is compared with some of the well-known optimization methods including firefly algorithm (FA), genetic algorithm (GA) and bacterial foraging (BF) algorithm. As can be seen, the BPSO took 100 iterations to be converged which is a lot less than that of the GA and FA.

## 5. Conclusion

This paper investigated the optimal allocation of a price-maker WT-ESS unit as a market participant in the day-ahead electricity market. The proposed independently operated unit, which is made up of 3 WTs and 3 ESSs, tried to find its most profitable locations for connection to the network with the aim of maximizing its profit within the 24-hour daily horizon, both in normal and congestion circumstances. The main problem was provided as a tri-level optimization model in which the first level defined the profit maximization of the price-maker unit, the second level expressed the power dispatch cost of the network from the perspective of the ISO and the third level was an effective TSIRC approach as a robust model that assured the maximization of the output power of the WTs during the operation. By using the KKT conditions, the tri-level model was transformed into a bi-level problem. An appropriate binary PSO optimization algorithm was implemented to find the optimal location of the WTs and ESSs considering the market participation model of the price-maker unit in an iteration process. The proposed

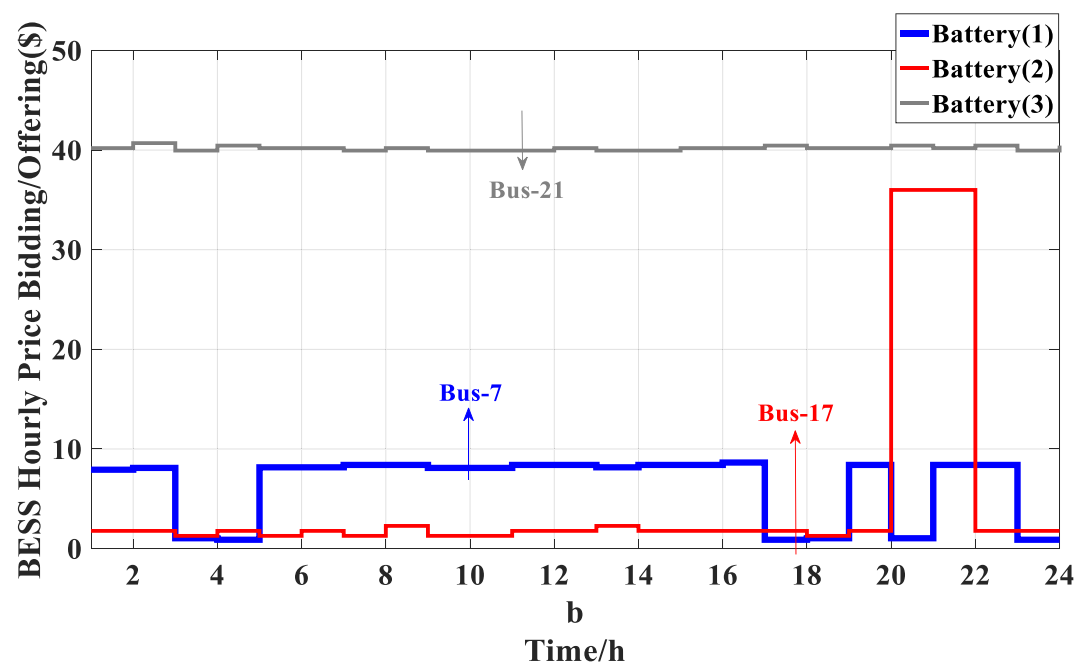
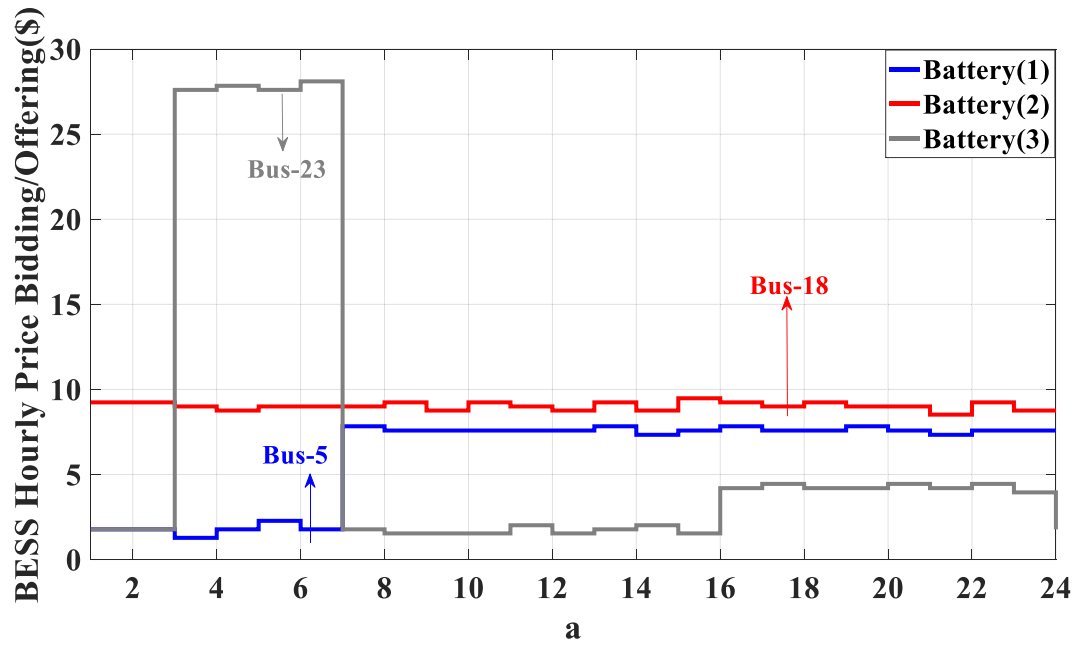

Fig. 6. BESSs hourly bidding and offering prices: (a) without TSIRC (b) with TSIRC.

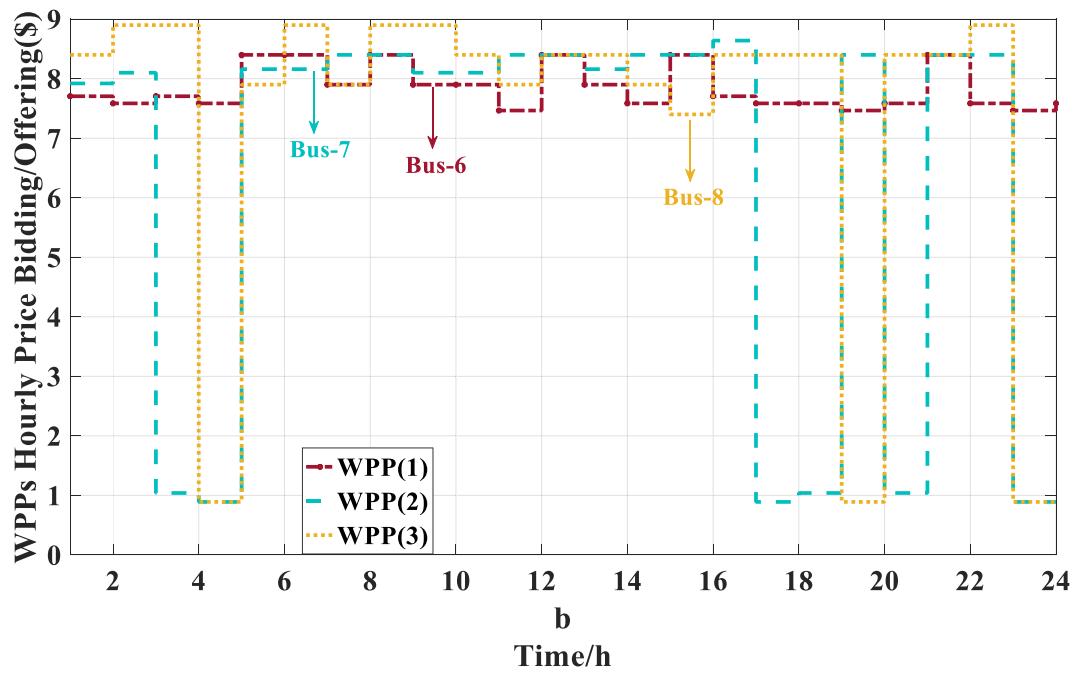
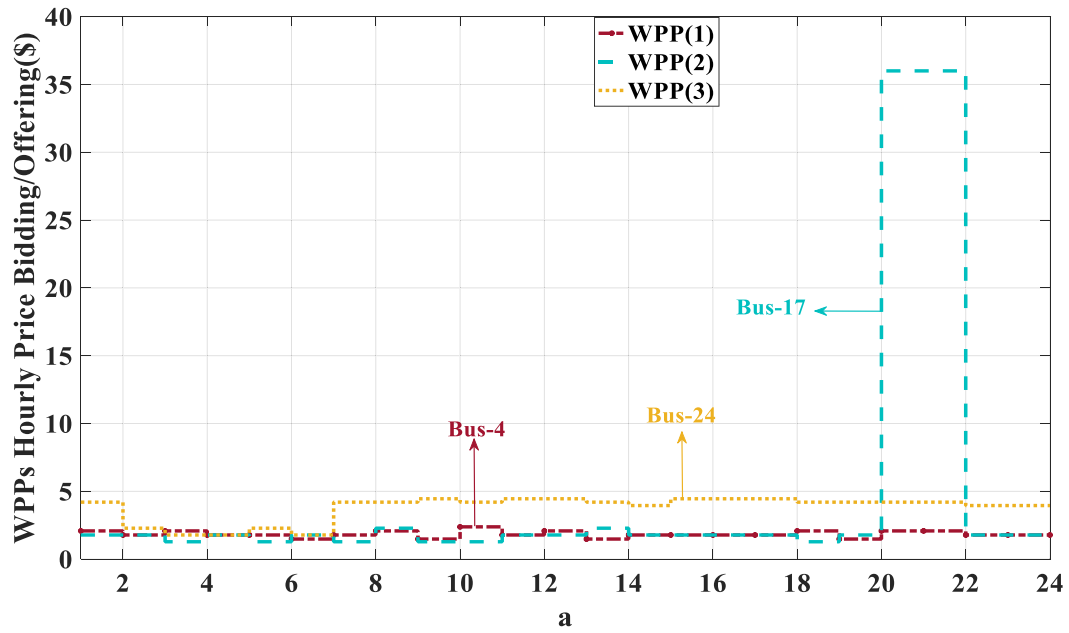

Fig. 7. The hourly bidding/offering prices of the WT: (a) without TSIRC (b) with TSIRC.

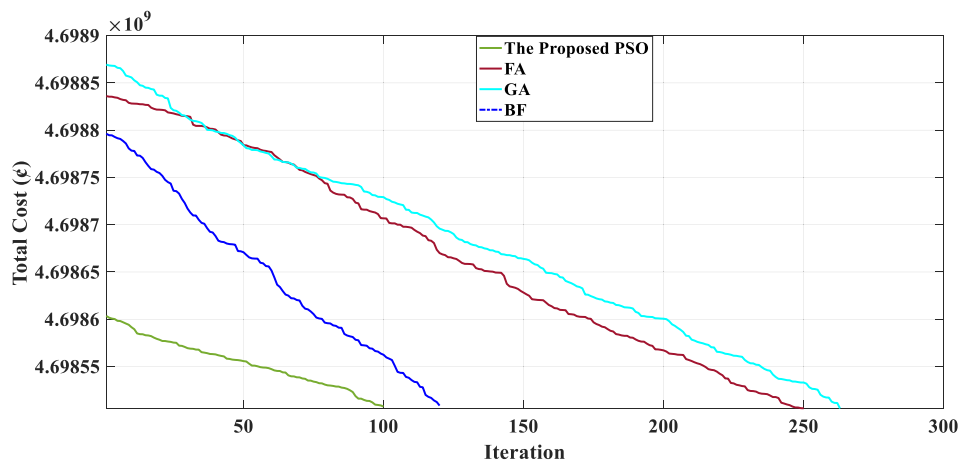

Fig. 8. Convergence of the proposed algorithm.

Table 2  
Comparison of different study cases.

Models	Battery Energy Storage Systems							Wind Power Plants						
	Battery (1)		Battery (2)		Battery (3)		Total Bid	WPP(1)		WPP(2)		WPP(3)		Total Bid
	Bus	Bid	Bus	Bid	Bus	Bid		Bus	Bid	Bus	Bid	Bus	Bid	
Basic model	7	195.59	8	194.09	9	389.68	779.36	7	195.59	8	194.09	13	329.8	719.48
Basic model during congestion	5	147.71	18	216.48	23	165.88	530.07	4	44.22	17	90.2	24	12.49	146.91
Proposed Model	6	445.46	7	191.93	20	637.39	1274.78	6	445.46	7	191.93	8	637.39	1274.7
Proposed Model during congestion	7	147.62	17	109.16	21	964.55	1221.33	6	188.19	7	147.62	8	171.56	507.37
Proposed Model With uncertainty	1	178.99	7	132.15	8	157.54	579.38	7	132.15	8	157.54	22	289.69	579.38

model was able to effectively determine the optimal locations of the WTs and ESSs during both congestion and normal circumstances. Also, the TSIRC method has led to an increase in the energy and price biddings of the WTs and ESSs while by optimally managing the congestion of the power lines, it improved the allocation process of the units, thus finding the most beneficial locations for WTs and ESSs even during congestion.

**CRedit authorship contribution statement**

**Hossein Chabok:** Conceptualization, Methodology, Software, Writing – original draft. **Jamshid Aghaei:** Supervision, Conceptualization, Methodology, Data curation, Writing – review & editing. **Morteza Sheikh:** Writing – original draft, Methodology, Visualization, Investigation. **Mahmoud Roustaei:** Writing – original draft, Software, Visualization, Investigation. **Mohsen Zare:** Writing – original draft, Visualization, Investigation. **Taher Niknam:** Conceptualization, Supervision. **Matti Lehtonen:** Conceptualization, Supervision, Writing – review & editing. **Miadreza Shafi-khah:** Supervision, Writing – review & editing. **João P.S. Catalão:** Supervision, Writing – review & editing.

**Declaration of Competing Interest**

The authors declare that they have no known competing financial interests or personal relationships that could have appeared to influence the work reported in this paper.

**References**

[1] Zhao H, Wu Q, Hu S, Xu H, Rasmussen CN. Review of energy storage system for wind power integration support. *Appl Energy* 2015;137:545–53.  
 [2] Adefarati T, Bansal RC. Integration of renewable distributed generators into the distribution system: a review. *IET Renew Power Gener* 2016;10(7):873–84.  
 [3] Awad ASA, El-Fouly THM, Salama MMA. Optimal ESS allocation and load shedding for improving distribution system reliability. *IEEE Trans Smart Grid* 2014;5(5):2339–49.

[4] Atwa YM, El-Saadany EF. Optimal allocation of ESS in distribution systems with a high penetration of wind energy. *IEEE Trans Power Syst* 2010;25(4):1815–22.  
 [5] Awad ASA, EL-Fouly THM, Salama MMA. Optimal ESS allocation for load management application. *IEEE Trans Power Syst* 2015;30(1):327–36.  
 [6] Giannitrapani A, Paoletti S, Vicino A, Zarrilli D. Optimal allocation of energy storage systems for voltage control in LV distribution networks. *IEEE Trans Smart Grid* 2016;8(6):2859–70.  
 [7] Mohammadi F, Gholami H, Gharehpetian GB, Hosseini SH. Allocation of centralized energy storage system and its effect on daily grid energy generation cost. *IEEE Trans Power Syst* 2016;32(3):2406–16.  
 [8] Ogunjuyigbe ASO, Ayodele TR, Akinola OA. Optimal allocation and sizing of PV/Wind/Split-diesel/Battery hybrid energy system for minimizing life cycle cost, carbon emission and dump energy of remote residential building. *Appl Energy* 2016;171:153–71.  
 [9] Nick M, Cherkaoui R, Paolone M. Optimal allocation of dispersed energy storage systems in active distribution networks for energy balance and grid support. *IEEE Trans Power Syst* 2014;29(5):2300–10.  
 [10] Yan N, Zhang Bo, Li W, Ma S. Hybrid energy storage capacity allocation method for active distribution network considering demand side response. *IEEE Trans Appl Superconduct* 2019;29(2):1–4.  
 [11] Wen S, Lan H, Fu Q, Yu DC, Zhang L. Economic allocation for energy storage system considering wind power distribution. *IEEE Trans Power Syst* 2015;30(2):644–52.  
 [12] Wogrin S, Gayme DF. Optimizing storage siting, sizing, and technology portfolios in transmission-constrained networks. *IEEE Trans Power Syst* 2014;30(6):3304–13.  
 [13] Zheng Yu, Dong ZY, Luo FJ, Meng Ke, Qiu J, Wong KP. Optimal allocation of energy storage system for risk mitigation of DISCOs with high renewable penetrations. *IEEE Trans Power Syst* 2014;29(1):212–20.  
 [14] Zheng Y, Hill DJ, Dong ZY. Multi-agent optimal allocation of energy storage systems in distribution systems. *IEEE Trans Sust Energy* 2017;8(4):1715–25.  
 [15] Ding S, Cao Y, Vosough M, Sheikh M, Almagrabi A. A directed acyclic graph based architecture for optimal operation and management of reconfigurable distribution systems with PEVs. *IEEE Trans Ind Appl* 2020.  
 [16] Baziar A, Akbarzadeh MR, Hajizadeh A, Marzband M, Bo R. A robust integrated approach for optimal management of power networks encompassing wind power plants. *IEEE Trans Ind Appl* 2020.  
 [17] Mohamed MA, Jin T, Su W. An effective stochastic framework for smart coordinated operation of wind park and energy storage unit. *Appl Energy* 2020;272:115228. <https://doi.org/10.1016/j.apenergy.2020.115228>.  
 [18] Li J, Zhang Z, Shen B, Gao Z, Ma D, Yue P, et al. The capacity allocation method of photovoltaic and energy storage hybrid system considering the whole life cycle. *J Cleaner Prod* 2020;275:122902.  
 [19] Xiong L, Yang S, Huang S, He D, Li P, Khan MW, Wang J. Optimal allocation of energy storage system in DFIG wind farms for frequency support considering wake effect. *IEEE Trans Power Syst*; 2021.

- [20] Ahmad AAL, Sirjani R, Daneshvar S. New hybrid probabilistic optimisation algorithm for optimal allocation of energy storage systems considering correlated wind farms. *J Storage Mater* 2020;29:101335. <https://doi.org/10.1016/j.est.2020.101335>.
- [21] Oskouei MZ, Mohammadi-Ivatloo B, Erdinc O, Erdinc FG. Optimal allocation of renewable sources and energy storage systems in partitioned power networks to create supply-sufficient areas. *IEEE Trans Sust Energy* 2021;12(2):999–1008.
- [22] Luo F, Meng Ke, Dong ZY, Zheng Yu, Chen Y, Wong KP. Coordinated operational planning for wind farm with battery energy storage system. *IEEE Trans Sust Energy* 2015;6(1):253–62.
- [23] Ding H, Pinson P, Hu Z, Wang J, Song Y. Optimal offering and operating strategy for a large wind-storage system as a price maker. *IEEE Trans Power Syst* 2017;32(6):4904–13.
- [24] Mohsenian-Rad H. Optimal bidding, scheduling, and deployment of battery systems in California day-ahead energy market. *IEEE Trans Power Syst* 2016;31(1):442–53.
- [25] Wang X, Shahidehpour M, Jiang C, Li Z. Resilience enhancement strategies for power distribution network coupled with urban transportation system. *IEEE Trans Smart Grid* 2018;10(4):4068–79.
- [26] Nikoobakht A, Aghaei J, Shafie-khah M, Catalão JPS. Interval based robust chance constrained allocation of demand response programs in wind integrated power systems. *IET Renew Power Gener* 2019;13(6):930–9.
- [27] Sheikh M, Aghaei J, Letafat A, Rajabdorri M, Niknam T, Shafie-Khah M, et al. Security-constrained unit commitment problem with transmission switching reliability and dynamic thermal line rating. *IEEE Syst J* 2019;13(4):3933–43.
- [28] Aien M, Fotuhi-Firuzabad M, Aminifar F. Probabilistic load flow in correlated uncertain environment using unscented transformation. *IEEE Trans Power Syst* 2012;27(4):2233–41.
- [30] Force RT. The IEEE reliability test system-1996. *IEEE Trans Power Syst* 1999;14(3):1010–20.
- [31] Sheikh M, Aghaei J, Chabok H, Roustaei M, Niknam T, Kavousi-Fard A, Shafie-Khah M, Catalão JPS. Synergies between transportation systems, energy hub and the grid in smart cities. *IEEE Trans Intell Transport Syst*; 2021.
- [32] Roustaei M, Niknam T, Salari S, Chabok H, Sheikh M, Kavousi-Fard A, et al. A scenario-based approach for the design of Smart Energy and Water Hub. *Energy* 2020;195:116931.
- [33] Sheikh M, Aghaei J, Rajabdorri M, Shafie-khah M, Lotfi M, Javadi MS, et al. Multiobjective congestion management and transmission switching ensuring system reliability. In: 2019 IEEE international conference on environment and electrical engineering and 2019 IEEE industrial and commercial power systems Europe (EEEIC/I&CPS Europe). IEEE; 2019. p. 1–5.
- [34] Kavousi-Fard A, Niknam T, Fotuhi-Firuzabad M. Stochastic reconfiguration and optimal coordination of V2G plug-in electric vehicles considering correlated wind power generation. *IEEE Trans Sust Energy* 2015;6(3):822–30.