



Vaasan yliopisto  
UNIVERSITY OF VAASA

**OSUVA** Open  
Science

This is a self-archived – parallel published version of this article in the publication archive of the University of Vaasa. It might differ from the original.

# High Switching Frequency Operation of a Single-Phase Five-Level Hybrid Active Neutral Point Clamped Inverter with a Model Predictive Control Approach

**Author(s):** Najjar, Mohammad; Shahparasti, Mahdi; Heydari, Rasool; Nymand, Morten

**Title:** High Switching Frequency Operation of a Single-Phase Five-Level Hybrid Active Neutral Point Clamped Inverter with a Model Predictive Control Approach

**Year:** 2022

**Version:** Accepted manuscript

**Copyright** ©2022 IEEE. Personal use of this material is permitted. Permission from IEEE must be obtained for all other uses, in any current or future media, including reprinting/republishing this material for advertising or promotional purposes, creating new collective works, for resale or redistribution to servers or lists, or reuse of any copyrighted component of this work in other works.

## **Please cite the original version:**

Najjar, M., Shahparasti, M. Heydari, R. & Nymand, M. (2022). High Switching Frequency Operation of a Single-Phase Five-Level Hybrid Active Neutral Point Clamped Inverter with a Model Predictive Control Approach. In: *2022 24th European Conference on Power Electronics and Applications (EPE'22 ECCE Europe)*. IEEE.  
<https://ieeexplore.ieee.org/abstract/document/9907682>

# High Switching Frequency Operation of a Single-Phase Five-Level Hybrid Active Neutral Point Clamped Inverter with a Model Predictive Control Approach

Mohammad Najjar<sup>1</sup>, Mahdi Shahparasti<sup>2</sup>, Rasool Heydari<sup>3</sup>, Morten Nymand<sup>3</sup>

<sup>1</sup> Schneider Electric, Kolding, Denmark

<sup>2</sup> School of Technology and Innovations, University of Vaasa, 65200, Vaasa, Finland

<sup>3</sup> University of Southern Denmark, Odense, Denmark

E-Mail: [mdn.najjar@gmail.com](mailto:mdn.najjar@gmail.com), [mahdi.shahparasti@uwasa.fi](mailto:mahdi.shahparasti@uwasa.fi),  
[Rasool.heydari@gmail.com](mailto:Rasool.heydari@gmail.com), [mny@sdu.dk](mailto:mny@sdu.dk)

## Keywords

«Voltage Source Inverter (VSI)», «Model Predictive Control», «Multi-level converters», «Silicon Carbide (SiC)», «Capacitor voltage balancing».

## Abstract

Wide bandgap (WBG) devices such as Silicon-Carbide (SiC) MOSFETs, can be utilized to increase the switching frequency of power electronic converters. The size of passive components of output filter can be reduced by increasing the switching frequency of converters or the number of output levels through employment of multilevel topologies. Therefore, the combination of multilevel converters and WBG switches with high switching frequency can improve the dynamic of converter. Meanwhile, a high bandwidth controller is also required to reach a fast dynamic response of the system. In this paper, an advanced model predictive control (MPC) approach, based on the concept of hysteresis current control, is presented for a single-phase five-level hybrid active neutral point clamped (ANPC) inverter. A hybrid modulation technique with different switching frequencies is considered in this paper. As a result, different semiconductor technologies including SiC and Si are employed in the structure of the converter. Considering the AC and DC sides mathematical modeling of the converter, a MPC with the ability to control the neutral point (NP) voltage is designed. Finally, experimental results show that by utilizing the SiC MOSFETs and the proposed advanced MPC structure, the inverter's switching frequency is increased, with lower current ripple and fast dynamic performance.

## Introduction

Multilevel converters offer lower  $dv/dt$ , common-mode voltage, current and voltage total harmonic distortion (THD), and smaller filter inductance compared to the conventional two-level converter [1], [2]. Among different utilization of multilevel converter, single-phase power converter have been employed in photovoltaic (PV), electric railway traction, and power factor correction applications [3]–[8]. One interesting topology for these applications is the hybrid active neutral-point-clamped (H-ANPC) converter. In the converter structure, eight switches are utilized and can generate up to five output voltage levels [5], [9], [10].

Different control strategies have been proposed for single-phase applications. Meanwhile, with the development of the advanced and fast microprocessor, the implementation of complex control algorithms such as model predictive control can be considered. The main concept of MPC control is based on the utilization of the discrete characteristics of power electronic converters. The system outputs' future behavior is predicted based on the mathematical model of the system and present values of outputs. In addition, system constraints and purposes are employed through a cost function. At each sampling time, the cost function is evaluated for different switching states, and the optimized solution will be utilized to determine the next switching state of the converter [11]–[13].

Amon various MPC techniques, finite control set MPC (FCS-MPC) is a popular MPC strategy. In this strategy, the output voltage vectors of a converter are considered as the control inputs, which are applied to handle the optimal control problem [9], [14]–[17]. Fast-dynamic response, simple implementation, and the ability to integrate advanced control objectives in the design of its cost function can be counted as the features of FCS-MPC [12], [14], [18]. Considering the elimination of switching modulators and inner control loops and their delays by employing the FCS-MPC, the system can be operated with higher bandwidth [19].

In this paper, an MPC based on hysteresis current control is proposed for a single-phase five-level hybrid ANPC inverter. A hysteresis band for the current of the filter inductor is defined to limit the current ripple. The proposed method is implemented by utilizing both a microprocessor and an FPGA. Thus, the overall sampling frequency of the controller is set to 100kHz. A prototype inverter with two different switch technologies, including Si and SiC MOSFETs, is selected to validate the controller.

## Structure of single-phase five-level Hybrid ANPC Inverter

The structure of the single-phase hybrid ANPC is shown in Fig.1. The converter is comprised of 8 switches and two dc-link capacitors. The hybrid switching states of this converter are listed in Table I. As it can be seen in Table I, five voltage levels at the output ( $v_{ab}$ ) of the converter can be obtained. During the positive half cycle  $S_5$  and  $S_8$  are conducting; meanwhile,  $S_6$  and  $S_7$  are in on-state condition at the negative half cycle. Thus, the switching frequency of  $S_5$ - $S_8$  is fundamental (low frequency switches). Meanwhile, during the positive and negative half cycles, the switching states of  $S_1$ - $S_4$  (high frequency switches) are altered to obtain different output voltage levels. Due to devices switching frequencies, two different switch technologies can be considered for low and high frequency switches. In this study, SiC and Si MOSFETs are employed in the structure of the converter.

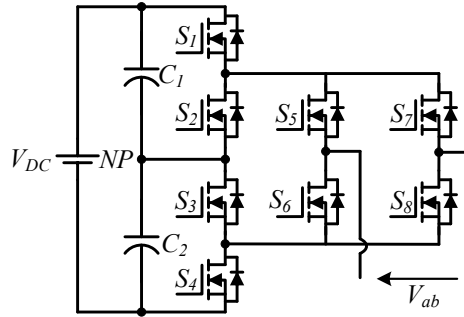

Fig. 1: The structure of the hybrid active neutral point clamped inverter.

**Table I: The switching states of 5-level single-phase ANPC**

Output Vector	Switching states								$v_{ab}$
	$S_1$	$S_2$	$S_3$	$S_4$	$S_5$	$S_6$	$S_7$	$S_8$	
$V_1$	1	0	0	1	1	0	0	1	$V_{dc}$
$V_2$	1	0	1	0	1	0	0	1	$V_{dc}/2$
$V_3$	0	1	0	1	1	0	0	1	$V_{dc}/2$
$V_4$	0	1	1	0	1	0	0	1	0
$V_5$	0	1	1	0	0	1	1	0	0
$V_6$	1	0	1	0	0	1	1	0	$-V_{dc}/2$
$V_7$	0	1	0	1	0	1	1	0	$-V_{dc}/2$
$V_8$	1	0	0	1	0	1	1	0	$-V_{dc}$

The general schematic of the system is shown in Fig. 2. As it can be seen, the load is supplied through an LC filter. To control the NP voltage, the effect of each vector on the NP voltage variation should be

considered. The output vectors can be divided into three groups of large, small, and zero vectors. The large ( $V_1, V_8$ ) and zero ( $V_4, V_5$ ) do not have any influence on the NP voltage. Meanwhile, the small vectors ( $V_2, V_3, V_5, V_6$ ) can change the NP voltage, in which the output current passes through one of the dc-link capacitors. Table II shows the effect of small vector on the NP voltage [9].

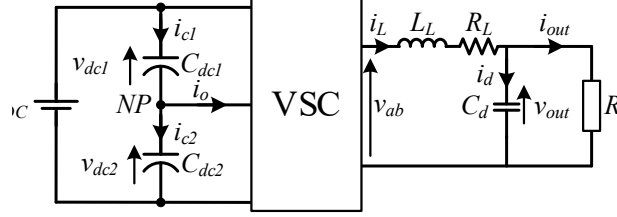

Fig. 2: The general schematic of the system.

**Table II: The effect of small vector on the NP voltage.**

Vector	Output current	$v_{NP}=v_{dc1}-v_{dc2}$
$V_2$	$i_L > 0$	↓
	$i_L < 0$	↑
$V_3$	$i_L > 0$	↑
	$i_L < 0$	↓
$V_6$	$i_L > 0$	↑
	$i_L < 0$	↓
$V_7$	$i_L > 0$	↓
	$i_L < 0$	↑

## Mathematical Modeling of the System

The mathematical model of the converter, including AC and DC sides, should be obtained to develop a MPC system. Considering the schematic of the system shown in Fig. 2, the voltage across the load ( $v_{out}$ ) and filter inductor current ( $i_L$ ) can be shown as state-space as follows [9]:

$$\frac{d}{dt} \begin{bmatrix} i_L \\ v_{out} \end{bmatrix} = A \begin{bmatrix} i_L \\ v_{out} \end{bmatrix} + B \begin{bmatrix} v_{ab} \\ i_{out} \end{bmatrix} \quad A = \begin{bmatrix} -\frac{R_L}{L} & -\frac{1}{L} \\ \frac{1}{C_d} & 0 \end{bmatrix}, B = \begin{bmatrix} \frac{1}{L} & 0 \\ 0 & -\frac{1}{C_d} \end{bmatrix} \quad (1)$$

where  $L_L, R_L$  are the inductance and resistance of filter inductor, and  $C_d$  is the value of the filter capacitor.

For the DC side of the converter, whenever the small vectors are applied the NP current ( $i_o$ ) is equal to the filter inductor current. Thus, the voltage of dc-link capacitors can be obtained through the following equations [9]:

$$i_{c1} = C_{dc1} dv_{dc1}/dt \quad (2)$$

$$i_{c2} = C_{dc2} dv_{dc2}/dt \quad (3)$$

Moreover, the NP voltage is defined as:

$$v_{NP} = v_{dc1} - v_{dc2} \quad (4)$$

Assuming the sampling frequency is relatively high, the equations can be discretized based on the discrete step time of  $T_s$ . For example, the voltages of dc-link capacitors are discretized as follows:

$$v_{dc1}(k+1) = v_{dc1}(k) + \frac{T_s}{C_{dc1}} i_{c1}(k) \quad (5)$$

$$v_{dc2}(k+1) = v_{dc2}(k) + \frac{T_s}{C_{dc2}} i_{c2}(k) \quad (6)$$

which  $v_{dc1}(k+1)$  and  $v_{dc2}(k+1)$  are the predictive voltages of upper and lower dc-link capacitors at the  $(k+1)^{\text{th}}$  instant.

## MPC Algorithm

The cost function for MPC should be defined to reach the desired purposes as tracking the reference voltage, keeping the current ripple of filter inductor in the hysteresis band, and regulating the NP voltage. Consequently, the cost function is comprised of three subfunctions defined as follows:

$$CF: |v_{out}(n+1)^* - v_{out}(n+1)| + \lambda_1 (|v_{dc1}(n+1) - v_{dc2}(n+1)|) + hys(n+1) \quad (7)$$

where  $\lambda_1$  is the weighting factor to balance the NP voltage. The first subfunction is used for tracking the reference voltage. The aim of the second subfunction is to keep the NP voltage constant and zero. The subfunction of  $hys(n+1)$  is employed to reduce the current ripple in the filter inductor, which is defined as follows:

$$hys(n+1) = \begin{cases} \infty, & \text{if } |i_L(k+1)| > |i_L^*(k+1)| + lim \ \& \ |i_L(k+1)| < |i_L^*(k+1)| - lim \\ 0, & \text{if } |i_L(k+1)| < |i_L^*(k+1)| + lim \ \& \ |i_L(k+1)| > |i_L^*(k+1)| - lim \end{cases} \quad (8)$$

where  $lim$  is the hysteresis band as it is shown in Fig. 3.

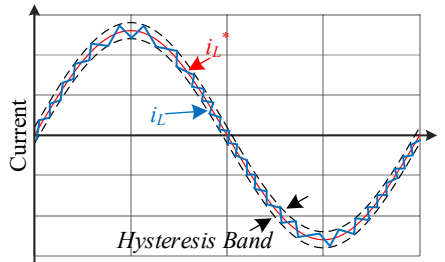

Fig. 3: The defined hysteresis band of the filter inductor current

Each of the output vectors ( $V_i$ ,  $i=1-8$ ) has a different effect on the value of the cost function (7) through (1), in which  $v_{ab}$  is replaced with the output voltage vectors. As mentioned earlier, the small vectors change the NP voltage and, consequently, the value of the cost function through (2) and (3). In each step, the value of cost function is calculated for all the vectors and a vector with minimum related cost function is chosen to apply.

## Experimental Results

To verify the performance of the proposed MPC, different experiments are performed. The prototype of the converter including an LC filter is shown in Fig. 4. To control the converter dSPACE Micro-Lab Box ds1202 is used. The suggested method is implemented in dSPACE microprocessor with a frequency of 100kHz. Meanwhile, the dSPACE FPGA is employed to apply the selected vector with consideration of deadtimes between switches. The parameters of the built system are listed in Table III.

The steady-state experimental results of the system are shown in Fig. 5. Fig. 5(a) shows the output voltage ( $v_{out}$ ), the inductor current ( $i_L$ ), and the load current ( $i_{out}$ ). In addition, Fig. 5(a) includes a zoomed view of the inductor current during the peak current.

The voltages of dc-link upper and lower capacitors ( $v_{dc1}$ ,  $v_{dc2}$ ) and the output of the converter ( $v_{ab}$ ) are shown in Fig. 5 (b). It can be seen, the proposed MPC regulates the NP voltage and controls the output voltage of the converter.

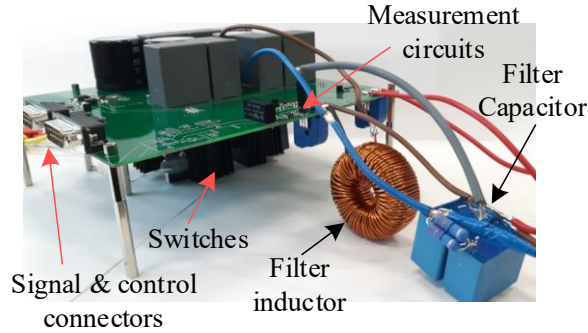

Fig. 4: The single-phase 5-level hybrid ANPC inverter with an LC filter.

Table III: The system parameters

Parameter	Definition	value
$V_{DC}$	DC supply voltage	200 V
$V_{out}$	The voltage across the load	110 V (rms)
$C_1, C_2$	DC-link capacitors	1 mF
$L$	Filter inductance	600 $\mu$ H
$R_L$	The resistance of filter inductor	0.1 $\Omega$
$C_d$	Filter capacitor	2 $\mu$ F
$R$	Load	20 $\Omega$
$f$	Reference output frequency	50 Hz
$T_s$	Sampling time	10 $\mu$ s

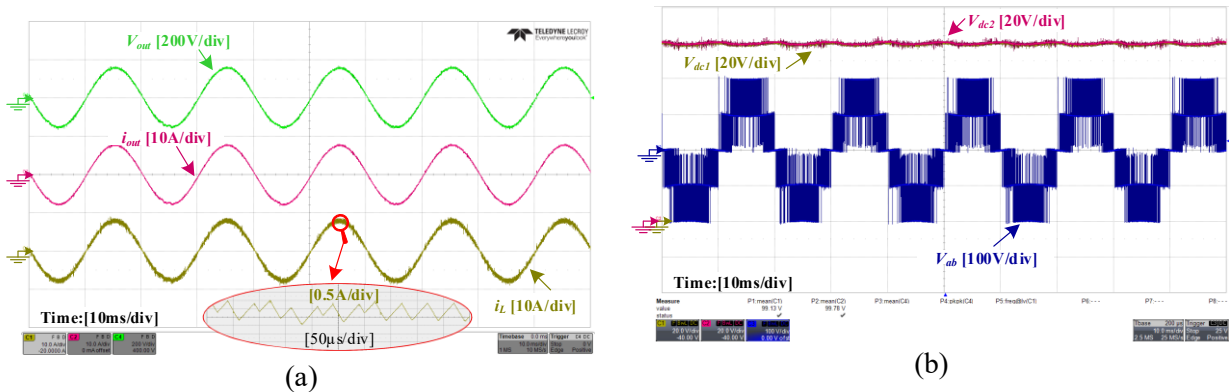

Fig. 5: The steady-state results of proposed MPC (a) The inductor current, output voltage, and load current (b) the voltages of dc-link upper and lower capacitors and output voltage of the converter.

The harmonics spectrum of load current is shown in Fig. 6. The main harmonics are in the frequency range up to 30kHz.

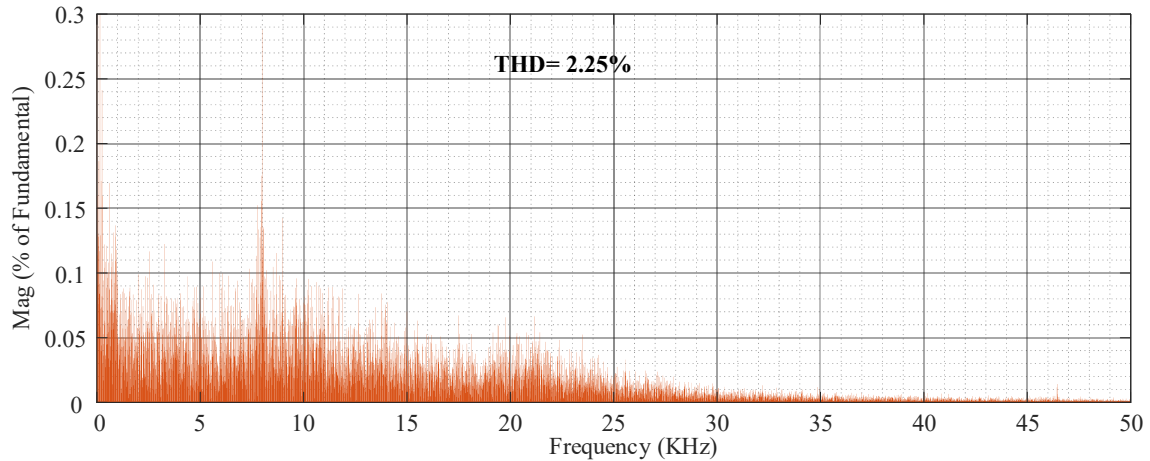

Fig. 6: The harmonics spectrum of output current.

To evaluate the performance of the suggested method during the transition, a step-change in the load value is introduced. The output voltage, the current of the filter inductor and load are shown in Fig. 7. As it can be seen, the proposed MPC is able to keep the output voltage constant quickly and to follow the reference waveform.

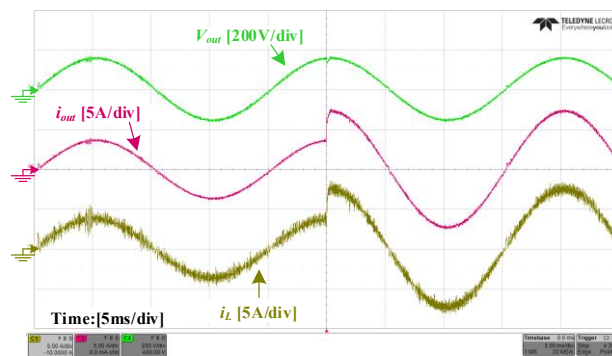

Fig. 7: The dynamic experimental results of proposed MPC when the load is changed.

## Conclusion

In this paper, an MPC based on the hysteresis current control for a single-phase 5-level hybrid ANPC has been proposed. In the structure of the converter, SiC MOSFETs are utilized to increase the switching frequency of the converter in order to reduce the size of the filter and current ripples. The proposed MPC was implemented with FPGA to have superior performance and fast dynamic response. Experimental results verify the performance of the proposed MPC both at steady-state and transition conditions.

## References

- [1] J. I. Leon, S. Vazquez, and L. G. Franquelo, "Multilevel Converters: Control and Modulation Techniques for Their Operation and Industrial Applications," *Proceedings of the IEEE*, vol. 105, no. 11, pp. 2066–2081, Nov. 2017.
- [2] J. Rodriguez, Jih-Sheng Lai, and Fang Zheng Peng, "Multilevel inverters: a survey of topologies, controls, and applications," *IEEE Transactions on Industrial Electronics*, vol. 49, no. 4, pp. 724–738, Aug. 2002.
- [3] M. Malinowski, J. I. Leon, and H. Abu-Rub, "Solar Photovoltaic and Thermal Energy Systems: Current Technology and Future Trends," *Proceedings of the IEEE*, vol. 105, no. 11, pp. 2132–2146, Nov. 2017.
- [4] S. B. Kjaer, J. K. Pedersen, and F. Blaabjerg, "A review of single-phase grid-connected inverters for photovoltaic modules," *IEEE Transactions on Industry Applications*, vol. 41, no. 5, pp. 1292–1306, 2005.
- [5] L. Zhang, K. Sun, L. Feng, H. Wu, and Y. Xing, "A family of neutral point clamped full-bridge topologies for transformerless photovoltaic grid-tied inverters," *IEEE Transactions on Power Electronics*, vol. 28, no. 2, pp. 730–739, 2013.

- [6] C. B. Jacobina, E. C. Dos Santos, N. Rocha, and E. L. L. Fabrício, "Single-phase to three-phase drive system using two parallel single-phase rectifiers," *IEEE Transactions on Power Electronics*, vol. 25, no. 5, pp. 1285–1295, 2010.
- [7] W. Song, X. Feng, and K. M. Smedley, "A carrier-based pwm strategy with the offset voltage injection for single-phase three-level neutral-point-clamped converters," *IEEE Transactions on Power Electronics*, vol. 28, no. 3, pp. 1083–1095, 2013.
- [8] M. S. Ortmann, S. A. Mussa, and M. L. Heldwein, "Generalized analysis of a multistate switching cells-based single-phase multilevel PFC rectifier," *IEEE Transactions on Power Electronics*, vol. 27, no. 1, pp. 46–56, 2012.
- [9] M. Najjar, M. Shahparasti, R. Heydari, and M. Nymand, "Model Predictive Controllers With Capacitor Voltage Balancing for a Single-Phase Five-Level SiC/Si Based ANPC Inverter," *IEEE Open Journal of Power Electronics*, vol. 2, 2021.
- [10] M. Najjar, M. Shahparasti, A. Kouchaki, and M. Nymand, "Operation and Efficiency Analysis of a Five-Level Single-Phase Hybrid Si/SiC Active Neutral Point Clamped Converter," *IEEE Journal of Emerging and Selected Topics in Power Electronics*, vol. 10, no. 1, 2022.
- [11] P. Cortés, M. P. Kazmierkowski, R. M. Kennel, D. E. Quevedo, and J. Rodriguez, "Predictive control in power electronics and drives," *IEEE Transactions on Industrial Electronics*, vol. 55, no. 12, pp. 4312–4324, 2008.
- [12] Y. Yang, H. Wen, M. Fan, M. Xie, R. Chen, and Y. Wang, "A Constant Switching Frequency Model Predictive Control Without Weighting Factors for T-Type Single-Phase Three-Level Inverters," *IEEE Transactions on Industrial Electronics*, vol. 66, no. 7, pp. 5153–5164, 2019.
- [13] S. Vazquez, P. Acuna, R. P. Aguilera, J. Pou, J. I. Leon, and L. G. Franquelo, "DC-Link Voltage-Balancing Strategy Based on Optimal Switching Sequence Model Predictive Control for Single-Phase H-NPC Converters," *IEEE Transactions on Industrial Electronics*, vol. 67, no. 9, pp. 7410–7420, 2020.
- [14] S. Vazquez, P. Acuna, R. P. Aguilera, J. Pou, J. I. Leon, and L. G. Franquelo, "DC-Link Voltage-Balancing Strategy Based on Optimal Switching Sequence Model Predictive Control for Single-Phase H-NPC Converters," *IEEE Transactions on Industrial Electronics*, vol. 67, no. 9, pp. 7410–7420, 2020.
- [15] X. Zhang, G. Tan, T. Xia, Q. Wang, and X. Wu, "Optimized Switching Finite Control Set Model Predictive Control of NPC Single-Phase Three-Level Rectifiers," *IEEE Transactions on Power Electronics*, vol. 35, no. 10, pp. 10097–10108, Oct. 2020.
- [16] R. O. Ramirez *et al.*, "Finite-State Model Predictive Control With Integral Action Applied to a Single-Phase Z-Source Inverter," *IEEE Journal of Emerging and Selected Topics in Power Electronics*, vol. 7, no. 1, pp. 228–239, Mar. 2019.
- [17] M. Novak, U. M. Nyman, T. Dragicevic, and F. Blaabjerg, "Analytical Design and Performance Validation of Finite Set MPC Regulated Power Converters," *IEEE Transactions on Industrial Electronics*, vol. 66, no. 3, pp. 2004–2014, Mar. 2019.
- [18] S. Vazquez *et al.*, "Model Predictive Control for Single-Phase NPC Converters Based on Optimal Switching Sequences," *IEEE Transactions on Industrial Electronics*, vol. 63, no. 12, pp. 7533–7541, 2016.
- [19] R. Heydari, T. Dragicevic, and F. Blaabjerg, "High-Bandwidth Secondary Voltage and Frequency Control of VSC-Based AC Microgrid," *IEEE Transactions on Power Electronics*, vol. 34, no. 11, pp. 11320–11331, Nov. 2019.