

## TOPICAL REVIEW

# Anti-Islanding Techniques for Integration of Inverter-Based Distributed Energy Resources to the Electric Power System

ÊNIO COSTA RESENDE<sup>1</sup>, MARCELO GODOY SIMÕES<sup>2</sup>, (Fellow, IEEE),  
AND LUIZ CARLOS GOMES FREITAS<sup>1</sup>

<sup>1</sup>Faculty of Electrical Engineering, Federal University of Uberlândia (UFU), Uberlândia 38400-902, Brazil

<sup>2</sup>School of Technology and Innovations, Electrical Engineering, University of Vaasa, 65200 Vaasa, Finland

Corresponding author: Luiz Carlos Gomes Freitas (lcfgreitas@ufu.br)

This work was supported in part by the Federal University of Uberlândia, and in part by the following Brazilian research funding agencies: Fundação de Amparo à Pesquisa do Estado de Minas Gerais (Fapemig) under Grant APQ-04929-22, Coordenação de Aperfeiçoamento de Pessoal de Nível Superior - Brasil (CAPES) - Finance Code 001, Conselho Nacional de Desenvolvimento Científico e Tecnológico (CNPq) under Grants 303085/2022-3, 407403/2022-1, 406881/2022-7.

**ABSTRACT** The emergence of microgrids and the increasing adoption of Distributed Generation Systems (DGS) have created an opportunity to replace traditional fossil fuels with renewable resources. Such a shift poses security and power quality challenges that must be addressed by academics and industrial research paradigms. Unintentional islanding is an important security concern, as it can result in power quality degradation, electrical hazards, and equipment damage. To address this problem and find efficient solutions, many anti-islanding techniques to detect and eliminate the phenomenon can be found in the specialized literature. These solutions can be classified as passive, active, remote, hybrid, or based on machine learning and signal processing techniques. In this context, this paper provides a comprehensive review of existing anti-islanding methods, highlighting their importance in preventing dangerous situations. The review includes a detailed analysis of the advantages and limitations found for each method, as well as its suitability for practical applications. The goal is to provide a valuable resource for researchers and practitioners in the field of distributed power systems, enabling them to choose the most appropriate anti-islanding method for their specific needs. Overall, this paper aims to address the challenges posed by unintentional islanding and promote the adoption of renewable energy resources for a more sustainable future.

**INDEX TERMS** Distributed generation, grid-tie inverters, islanding detection, microgrid, non-detection zone, power quality, renewable energy.

## I. INTRODUCTION

The global concern with sustainability, along with the need to diversify the global energy production matrix, has been the great catalyst of the growing penetration of renewable resources-based distributed generation into the distribution grid. Although Distributed Energy Resources (DERs) have

significant economic potential, their emergence presents a range of electrical safety challenges for power systems engineers and researchers. The main considerations that must be addressed include: short-circuits, voltage sags and swells, power quality degradation, phases unbalancing, and the main topic of this work: Islanding [1].

The islanding phenomenon is defined as the electrical operation of DGS even after the distribution or transmission electrical grid interruption [2]. The phenomenon can be

The associate editor coordinating the review of this manuscript and approving it for publication was Fabio Mottola<sup>1</sup>.

intentional or unintentional. It is important to note that intentional islanding has a positive impact, as it is an important way to electrically feed isolated areas or to maintain power supply in areas affected by natural disasters. Conversely, unintentional islanding presents a range of dangerous risks [3], such as: (1) Personal safety since maintenance personnel may assume the lines are shut down and perform maintenance procedures without adopting the necessary safety considerations; (2) Overvoltage and over frequency since after the loss of mains, voltage and frequency can extrapolate the allowed range of values and cause damage to equipment; (3) Power quality degradation due to the interactions between the harmonic content of the output inverter current and the local load impedances; (4) Reconnection out of phase since reconnecting out of phase can cause high transient torques to synchronous generators or other rotating machines.

The main causes of the unintentional islanding phenomenon are deliberate shutdown of the electrical grid due to maintenance procedures, electrical faults, human mistakes, or sabotage [4]. Consequently, a massive number of Anti-Islanding Protection (AIP) strategies were proposed to guarantee fast and reliable inverter shutdown after the islanding condition formation. Those methods can be classified according to their location and operating principle.

According to the location, AIP methods are divided into remote and local. Remote methods, also known as grid-resident methods are located on the utility side and provide a highly accurate detection, eliminating the problem of the Non-Detection Zone (NDZ) that will be addressed over the next sections. Despite their accuracy, remote solutions face the problem of high cost and implementation complexity [5], once they depend on high-level communication technologies. The main examples of strategies of this group are Impedance Insertion [6], Power-Line Carrier Communication [7] and Transfer-Trip Schemes [8], Phasor Measurement Unit [9], Micro Phasor Measurement Unit [10], and SCADA [11].

On the other hand, local AIP solutions, also known as inverter-resident methods, are embedded in the inverter microprocessor. Due to its low-cost implementation, local methods are widely common in residential inverters. Despite its popularization, local AIP algorithms are prone to false tripping and large NDZ. These problems, however, can be mitigated and almost eliminated by the application of mathematical or computational tools such as positive voltage or frequency feedback and machine learning algorithms. This way, one can see that remote AIP reach their reliability through high financial prices, while local AIP reliability depends on the intellectual efforts of academic and industrial research.

Local methods, on the other hand, can be divided into three categories: passive, active, and hybrid solutions. The passive methods are characterized by the pure monitoring of some electrical information in the Point of Common Coupling (PCC) [12], such as frequency [13], rate of change of frequency [14], voltage [15], phase jump [16], total or

individual [17] harmonic distortion. The main advantage of passive AIP lies in the fact that they are non-intrusive in relation to power quality. Nevertheless, they suffer from low accuracy and high NDZ. Differently, active AIP inserts small perturbances in some variables of the inverter operation. The main goal is to create conditions to destabilize the inverter after the grid interruption, deviating the operation point out of the range of the limits imposed by international standards [18]. Representative examples of this category include frequency and voltage drift-based methods, harmonic insertion, and high frequency signal injection. Active islanding detection involves a trade-off between efficiency and its impact on power quality.

Hybrid AIP solutions work as an average of the strengths and drawbacks of passive and active AIP. The operating principle involves monitoring electrical variables, and, if the control system suspects an islanding contingency, an active perturbation is inserted into some of the inverter parameters for a preset period. Therefore, if islanding is confirmed, the inverter is shut down. If the islanding hypothesis is rejected, the active perturbation is deactivated. The main representatives of this kind of solution are SFS-based approaches [19], Voltage unbalance and frequency set point [20], ROCOF-based methods [21], Voltage and real power shift [22] and SMS-based approaches. Hybrid AIP combines the benefits and drawbacks of both active and passive solutions. In this sense, it will present less harmonic distortion than the active methods but more than the passive solutions. Regarding the NDZ, hybrid schemes will have a smaller NDZ than passive methods but a larger one than active solutions.

Recently, many authors have focused on the development of AIP protection based on artificial intelligence or machine learning algorithms such as Artificial neural network (ANN) [23], Deep Learning (DL) [24], Decision tree (DT) [25], Fuzzy logic [26], Support vector machine (SVM) [27], ANFIS [28]. The great advantage of these approaches lies in the no need of communication lines. Additionally, there is no intrusion in relation to the power quality and in efficiency. These methods, however, depend on a high computational burden and on an elevated number of sensors depending on how much are the inputs of the algorithm. Finally, there is another set of AIP methodologies based on passive detection that use signal processing methods to improve durability, reliability, and effectiveness, namely: Fourier Transform (FT) [29], Wavelet Transform (WT) [30], Stockwell Transform (ST) [31], Mathematical Morphology (MM) [32], Kalman Filter (KF) [33], Variation Mode Decomposition (VMD) [34] and Empirical Mode Decomposition (EMD) [35].

Given this scenario, it is noted that the development of AIP strategies attracts great interest from the scientific community and several authors have contributed to the development of innovative and, above all, effective techniques. Many authors dedicated their time and effort to deepen their knowledge and make available to the scientific community works that demonstrate the state of the art on AIP strategies.

In [36] the authors presented an analysis of 117 works that inserts an important discussion about the future of islanding detection strategies. The possibility of emerging technologies such as machine learning or signal processing technologies occupying the state of the art of AIP strategies was discussed, however, it lacks a deeper study of the remote techniques and does not cover the timeline evolution of the active strategies.

In [3] the authors carried out a deep analysis of 96 works congregating not only the passive and active AIP strategies but also local hybrid and remote solutions. This paper presents one of the first studies related to smart AIP strategies for power systems and microgrids, providing a comprehensive assessment of their strengths and weaknesses. However, important passive strategies such as harmonic detection and voltage unbalance were not analyzed. Furthermore, it does not delve into recent advances reported in the technical literature regarding hybrid and active anti-islanding techniques, nor does it fully cover machine learning and signal processing technologies.

In [37], a comprehensive review of passive, hybrid, and active techniques is provided. The main strength of this paper lies in comparing the Non-Detection Zone (NDZ) of passive approaches to key network code requirements. Furthermore, it offers a detailed examination of the historical development of passive and active solutions, explaining not only their basic principles but also the strategies employed to deal with their limitations. However, this review does not address remote strategies as well as smart and signal processing-based techniques.

On the other hand, in [3] the authors contributed by presenting a review of AIP approaches which covers the main remote, active, passive, and hybrid technologies. However, it falls short in exploring recent advances in passive and active methods, neglects remote PMU and Micro PMU-based methods, and lacks a comprehensive analysis of key challenges encountered in AIP research, including AIP regulatory requirements.

Some other works focus on scrutinizing specific approaches rather than providing a holistic view of the specialized technical literature. In [38], for example, a systematic review of intelligence-based AIP approaches is provided. The analysis considers the main intelligent classifiers and technologies used to extract features from the detected data. In [39], a complete review of AIP techniques based on signal processing is performed and in [40] the authors summarized the main AIP patents granted in the USA.

While each work has its merits, the specificity of their proposals prevents them from adequately addressing the significant research gap concerning anti-islanding protection techniques. This gap is mainly related to the lack of a comprehensive review that consolidates the main regulatory requirements and identifies the main challenges that anti-islanding strategies must overcome to be functional. In addition, it presents a timeline of the evolution of the main methods, incorporating the most recent contributions found in the specialized technical literature.

Therefore, in light of what has been exposed, this work intends to contribute to the scientific community by presenting, in Section II, a precise description of the general AIP theory, highlighting the main challenges for correct islanding detection and the technologies for NDZ demarcation; in Section III the authors present a review of the main grid code requirements for islanding protection, contemplating the test methodologies and the recommended detection thresholds; Section IV is dedicated to present a complete review regarding remote, passive, active, hybrid, machine learning, and signal processing-based approaches, highlighting their timeline evolution and solutions to address each approach's drawbacks; finally, in Section V the concluding remarks found through the analysis of 215 technical documents are presented.

## II. STANDARDS AND ISLANDING DETECTION

Despite all the economic, social and environmental opportunities that come with the growing penetration of renewable resources-based DGS, it can also generate a series of problems of electrical security and power quality degradation. In this context, the commercialization of inverters or other technologies related to the interconnection of DGS into the main grid must obey the recommendations of the Standards. This section, in this sense, goals to present the main Standards recommendations about the integration of the DGS into the main grid. Posteriorly, it will carry out a revision about the considerations of AIP. Table 1 summarizes the main voltage, frequency, DC current injection, voltage, frequency total and individual harmonic content recommended thresholds of the following Standards: ABNT NBR 16149 [41], IEEE 929-2000 [2], IEEE 1547-2018 [42], UL741 [43].

### A. AIP STANDARDS RECOMMENDATIONS

The anti-islanding protection is a mandatory feature for inverter commercialization and for the connection of DGS in the main utility grid. Several Standards provide recommendations on the minimum requirements for Anti-Islanding Protection (AIP) to commercialize inverters and connect Distributed Generation Systems (DGS) to the main utility grid. In general, there is no consideration if the AIP must be a physical device or a code embedded into the inverter microprocessor or whether the adopted solution should be an active or a passive method. Despite the differences between the normative texts, all of them determine the same setup for the islanding detection test procedure. Figure 1 illustrates the generic setup for an AIP test. It is formed by a DC source connected to the same point that an RLC parallel load and an AC source. The DC source can be a PV plant simulator or a real one. In relation to the AC source, it can be a controlled source or the main grid, since some quality power criteria be reached: the amplitude must be  $\pm 2\%$  of the nominal value, the frequency must be kept at  $\pm 0.1$  Hz of its rated value and the THDv must be lower than 2.5%. For three-phase systems, the phase delay between the phase voltages must be  $120^\circ \pm 1.5^\circ$ .

TABLE 1. Standards considerations.

Standards	ABNT NBR 16149		IEEE 929-2000		IEEE 1547-2008		UL1741		
Rated Power	-		10 kW		30 kW		-		
	Order (h)	Threshold	Order (h)	Threshold	Order (h)	Threshold	Order (h)	Threshold	
THD	3-9	< 4.0 %	3-9	4.0%	3-9	4.0%	3-9	4.0%	
	11-15	< 2.0 %	11-15	2.0%	11-15	2.0%	11-15	2.0%	
	17-21	< 1.5%	17-21	1.5%	17-21	1.5%	17-21	1.5%	
	23-33	< 0.6 %	23-33	0.6%	23-33	0.6%	23-33	0.6%	
					>33	0.3%	>33	0.3%	
	2-8	< 1.0 %	Even components must be <25% than the respective odd one.						
	10-32	< 0.5 %							
		DHT<5%		DHT<5%				2-10	1%
								12-16	0.5%
							18-22	0.25%	
							24-34	0.15%	
							>34	0.075%	
Voltage Deviation	Range (%)	Time (s)	Range (%)	Time (s)	Range (%)	Time (s)	Range (%)	Time (s)	
	V<80	0.4	V<50	0.1	V<50	0.16	V<50	0.16	
	80≤V≤110	-	50≤V<88	2	50≤V<88	2	50≤V<88	2	
	110<V	0.2	110≤V<120	2	110≤V<120	1	110≤V<120	1	
			V≥120	0.05	V≥120	0.16	V≥120	0.16	
Frequency Deviation	Range (Hz)	Time (s)	Range (Hz)	Time (s)	Range (Hz)	Time (s)	Range (Hz)	Time (s)	
	59.5<f<60.5	-	49<f<51	0.2	59.3<f<60.5	-	58.5 < f < 60.5	-	

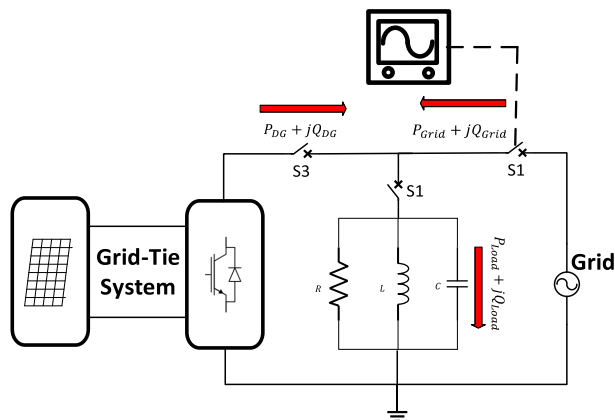

FIGURE 1. General setup for AIP test recommended by the cited standards.

The main goal of the load is to mitigate the influence of the utility grid on the equilibrium of the system. Thus, the resistive parameter must exactly match the inverter output power, reducing the active power demanded from the grid, and the LC pair must resonate at the rated grid frequency, in order to diminish the reactive power contribution from the utility grid. In this sense, the equations (1), (2) and (3) demonstrate the calculus of R, L, and C, respectively. Due to the

non-idealities of the load parameters, such as the resistance of the inductors and capacitors and the residual inductance of the line, it is necessary to monitor the grid current contribution. Small adjustments to the load parameters must be performed until the fundamental component of the grid current is less than ±1% of the fundamental order of the inverter output current.

$$R = \frac{V^2}{P} \tag{1}$$

$$L = \frac{V^2}{2\pi f_0 P Q_f} \tag{2}$$

$$C = \frac{Q_f P}{2\pi f_0 V^2} \tag{3}$$

where  $Q_f$  is the load quality factor,  $P$  is the output-rated power,  $f_0$  is the resonant frequency and  $V$  is the nominal voltage.

It is important to mention that the previous equations are the nominal values of load parameters. Beyond the values coming from those mathematical relations, it is important to perform small variations in the resistive and in one of the reactive (inductance or capacitance) parameters of the load in order to reach all of the Standard recommendations. More than that, it is necessary to conduct islanding tests for

different power conditions. The test can be performed either with a passive load or an electronic one [44], [45].

Multiple standards provide recommendations for carrying out AIP tests on distributed generation systems. Standard [2] recommends repeating the AIP test with varying reactive parameters of the load (inductor or capacitor) in the range of 95% to 105% for 1% adjustments, at power levels of 25%, 50%, 100%, and 125%. Standard [64] recommends conducting the AIP test at power levels of 100%, 66%, and 33%, with adjustments to resistive and capacitive parameters in the same range as [2]. Standard [68] also recommends power levels of 100%, 66%, and 33%, with positive and negative adjustments to reactive parameters in the range of 95% to 105% for the lower power levels and  $\pm 5\%$  for the highest power level. The Japanese Standard [50] requires testing AIP for different types of loads and multiple distributed generation units, with each working at 100% of its rated power. The maximum detection time ranges from 0.5s for passive schemes to 1s for active tactics.

### III. ANTI-ISLANDING THEORY

As previously mentioned, the islanding phenomenon can occur intentionally or unintentionally. Intentional islanding is a powerful strategy, applied in the contexts of cogeneration, hybrid photovoltaics systems or microgrids, that can be used to ensure power to a locality even in the absence of an external electrical grid [1]. In addition, intentional islanding can provide reliable power to consumers during blackouts or other electrical faults and allows power utilities to perform maintenance procedures without interrupting the energy supply.

The unintentional islanding, in turn, is defined as an unexpected interruption in the grid and has no positive benefits. In fact, it can lead to several negative consequences, ranging from degradation in power quality to the real risk of fatal electrical accidents. Unintentional islanding is especially dangerous due to its distinct characteristics. Unlike other electrical contingencies such as short circuits, flickers, or voltage fluctuations that produce significant and abrupt variations in electrical parameters and trigger protection devices, unintentional islanding can occur without causing noticeable changes in voltage, current, or frequency over a certain period. This can create a false sense of normality and make it difficult to detect the grid interruption [46].

In this context, it is important to understand how the electrical variables behave during an islanding occurrence, including the role of the local load in the variation of parameters before and after disconnection from the grid. During normal operation, there are active and reactive power contributions flowing from the DGS and from the utility grid to the local load, according to (4) and (5).

$$P_{load} = P + \Delta P \tag{4}$$

$$Q_{load} = Q + \Delta Q \tag{5}$$

where:

- P and Q – Active and reactive power from the DGS;
- $P_{load}$  and  $Q_{load}$  – Active and reactive power of the load;
- $\Delta P$  and  $\Delta Q$  – Active and reactive power of the grid;

During normal operation, the PCC voltage is controlled by the external grid. However, after an islanding event, the PCC voltage will be determined by the interaction between the DGS output current and the load impedance. In [47], the relationship between the PCC voltage before and after the grid interruption is derived and presented in equation (6). One can note that the voltage variation depends on the mismatch between the power supply from the DGS and the power demand of the load. In a situation of equilibrium generation-consume, the voltage will not present significant modification and, therefore, no voltage relay will be tripped.

$$V' = \sqrt{\frac{P}{P_{load}}} V \tag{6}$$

where:

- $V'$  – PCC voltage after the islanding;
- $V$  – PCC voltage before the islanding;

The angular frequency behavior, in turn, is given by (4). As it is possible to notice, the angular frequency of the electrical islanding is influenced by the reactive parameters of the local load. If the reactive parameters of the local load are such that  $Q_{load} = 0$  at the nominal grid frequency, (7) will be reduced to (8), which represents the resonance frequency. Therefore, if the pair LC has resonance at the grid nominal frequency, the frequency of the island will not vary.

$$\omega' = \frac{-\frac{Q_{load}}{CV'} + \sqrt{\left(\frac{Q_{load}}{CV'}\right)^2 + \frac{4}{LC}}}{2} \tag{7}$$

$$\omega' = \frac{1}{\sqrt{LC}} \tag{8}$$

Finally, it is important to highlight the voltage harmonic behavior. During normal operation, the DHTv is determined by the interaction of the harmonic content of the inverter output current and the equivalent impedance of the grid and the load. After the grid interruption, however, the DHTv is the product of the inverter current harmonic content and the load impedance. In general, ( $Z_{load} \gg Z_{grid}$ ) and, therefore, the parallel equivalency of the two impedances produces less THDv than the load one itself. This way, the problem of the increasing of voltage harmonic degradation is justified, especially for strong grids. Exceptions can be found in the weak grid context.

The next subsections will address the main challenges for islanding detection. They will cover the following topics: NDZ, detection time, power quality degradation, implementation cost, computational burden, multi-DG efficiency, quality factor of the load and, fault detection zone.

TABLE 2. AIP standards recommendations.

Standard	$Q_f$	Detection time	Frequency (Hz)	Voltage (V)	Power Conditions	Parameter Variation	Multiple inverter
IEEE Std. 1547-2003	1	$t < 2$ s	[59.3:60.5]	[0.88:1.1]	33%, 66%, 100%	$\Delta P$ : [95%: 105%] $\Delta Q$ : [95%: 105%]	No
IEEE Std. 929-2000	2.5	$t < 2$ s	[59.3: 60.5]	[0.88:1.1]	25%, 50%, 100%, 125%	$\Delta P$ : [95%: 105%] $\Delta Q$ : [95%: 105%]	No
IEC 62116	1	$t < 2$ s	[58.5: 61.5]	[0.85:1.15]	33%, 66%, 100%	$\Delta P$ : $\pm 5\%$ ; $\pm 10\%$ $\Delta Q$ : $\pm 5\%$ ; $\pm 10\%$	No
UL 1741	$\leq 1.8$	$t < 2$ s	Set value	Set value	33%, 66%, 100%	$\Delta P$ : [95%: 105%] $\Delta Q$ : [95%: 105%]	No
JETGR000 3-4-1.0	0 (+ rotating machinery)	P: $t < 0.5$ s A: $0.5$ s $< t < 1$ s	Set value	Set value	33%, 66%, 100%	$\Delta P$ : $\pm 5\%$ ; $\pm 10\%$ $\Delta Q$ : $\pm 5\%$ ; $\pm 10\%$	Yes (up to 10)

**A. NON-DETECTION ZONE (NDZ)**

The NDZ can be defined as the set of load conditions in which an AIP is not capable of detecting the grid interruption. It is, therefore, an important criterion for evaluating the performance of an AIP scheme, as it indicates a priori whether the scheme can meet all the detection standards requirements. In this context, the literature has developed four principal NDZ mapping methodologies: the  $\Delta P \times \Delta Q$  plan, the  $L \times C_{norm}$  plan, the  $Q_f \times f_0$  plan and the  $Q_f \times C_{norm}$  plan.

The  $\Delta P \times \Delta Q$  plan, also called, power mismatch space, relates the active and the reactive power contributions of the grid in the imminence of the islanding. This mapping strategy is mainly used for passive solutions, once it only considers the influence of the grid on the electrical variables' behavior. Therefore, the  $\Delta P \times \Delta Q$  plan only forecasts the voltage and frequency drift tendency imposed by the local load. Active or hybrid strategies, on the other hand, insert disturbances proposedly. Thus, in an islanding occurrence, there will be two driving forces acting over the electrical variables of the PCC: one imposed by the local load and other imposed by the inserted disturbance. In this scenario, the AIP literature developed other methodologies capable of recognizing and contemplating, in the same model, the two drift influences.

Thus, to ensure the NDZ mapping of active methods, [48] proposed the  $L \times C_{norm}$  plan that relates the load inductance to the load normalized capacitance, defined by (9). Despite its adherence to the active AIP schemes, neither the inductance nor the normalized capacitance considers the resistive load parameter (R), being necessary to plot the NDZ for each possible R value.

$$C_{norm} = \frac{C}{\omega_o L} \tag{9}$$

where:

- C – Load Capacitance [F];
- $\omega_o$  – Nominal grid angular frequency [rad/s];
- L – Local Load Inductance [H];

Following the evolution timeline of the NDZ mapping technologies, [49] proposed the  $Q_f \times f_0$  plan that relates, respectively, the load quality factor and its resonance frequency. The  $Q_f$  can be defined as the ratio between the power absorbed and the power consumed by the load and is

mathematically established by (10). The  $f_o$ , in turn, is known as the frequency in which the inductive and the capacitive reactance are equal and its value is indicated by (11). By (10) it is possible to notice that  $Q_f$  is determined in function of the load R, eliminating the need of plotting the NDZ for each possible value of the load resistance.

$$Q_f = R \sqrt{\frac{C}{L}} \tag{10}$$

$$f_o = \frac{1}{2\pi \sqrt{LC}} \tag{11}$$

where:

- C – Load Capacitance [F];
- R – Load Resistance [ $\Omega$ ];

Nonetheless, this plan has a disadvantage when compared to the Anti-Islanding Standards recommendations, since it is mandatory to test the AIP in different conditions, making small adjustments in the load reactive parameters. Therefore, it was proposed the  $Q_f \times C_{norm}$  plan that relates the load quality factor to the normalized capacitance [50]. In this sense, the NDZ is the area of the  $Q_f \times C_{norm}$  plan located between two curves, relative to the upper and lower thresholds of frequency variation. The lower curve refers to the maximum frequency allowed by the normative texts, while the upper curve refers to the minimum operating frequency allowed by the normative texts, as determined by (12) and (13), respectively.

$$C_{min} = 1 - \frac{2(\omega_{max})}{\omega_o} + \frac{tg(\theta_{inv})}{Q_f} \tag{12}$$

$$C_{max} = 1 + \frac{2(\omega_{min})}{\omega_o} + \frac{tg(\theta_{inv})}{Q_f} \tag{13}$$

where:

- $C_{min}$  – Normalized capacitance of the lower curve;
- $C_{max}$  – Normalized capacitance of the upper curve;
- $\omega_{min}, \omega_{max}$  – Minimum and maximum angular frequency thresholds, respectively;
- $\theta_{inv}$  – Phase difference between the PCC voltage and the inverter output current.

Finally, the NDZ is described by (14).

$$C_{min} < C_{norm} < C_{max} \quad (14)$$

### B. DETECTION TIME

One of the main Key Performance Indicators (KPIs) for AIP performance is the time elapsed between the islanding occurrence and its detection, called detection time. The main standards determine this time cannot exceed 1s [51] or 2s [2]. However, the literature has already proposed AIP schemes capable of detecting grid interruption in less than 100ms [46].

### C. POWER QUALITY DEGRADATION

Power quality emerges as a critical consideration in the integration of renewable resources into distribution grids. Regulatory codes impose stringent limits on both total harmonic distortion and individual harmonic levels. In this context, active and hybrid AIP schemes need to inject disturbances on some of the inverter parameters and, therefore, can lead to power quality degradation. In this sense, some strategies intend to create a phase difference for drifting the frequency and, therefore, can affect the output inverter power factor. Other solutions insert distortion on the current waveform increasing the THDi. This can result in the inverter failing to meet THDi thresholds set by industry standards for marketable products, potentially leading to disqualification from commercial use. In this sense, the choice of an AIP scheme must consider a trade-off relation between efficiency and THDi.

### D. IMPLEMENTATION COST

Generally speaking, active, passive or hybrid AIP technologies can be embedded in a microprocessor, being implemented without extra costs, especially in inverter-based DGS. The remote techniques, on the other hand, depend on extra devices connected to the PCC [52] or high-cost communication structures [8] which make them economically unfeasible for medium or small DGS. Those techniques, therefore, present a trade-off relation between the AIP effectivity and the cost of the communication lines. Although it is a commonly mentioned fact, the literature of remote AIP still lacks detailed studies to determine the optimum efficiency-investment point for different contexts.

### E. COMPUTATIONAL BURDEN

The computational burden can be defined as the number of computational efforts a microprocessor must employ to perform a determined task. In [53], is concluded that the computation efforts demanded by the modern deep learning algorithms are growing faster than the resources needed to train the model. This fact, in turn, alerts to the computational burden each AIP scheme demands to perform the islanding detection, specialty for those that are based on machine learning or signal processing techniques. Machine learning-based algorithms demand a long dataset for algorithm training in order to achieve accuracy. In this sense, designers must con-

sider the trade-off relation between computation burden and efficiency, achieving an optimum point for each application.

### F. FAULT DETECTION ZONE (FDZ)

The Fault Detection Zone can be defined as the set of operational cases in which an AIP system provides a false positive islanding diagnosis. The problem derives from the fact that some non-islanding contingencies such as the switching of motors or capacitor banks, for instance, can provoke transient changes in the voltage magnitude, current or frequency and provoke false detection. This problem has been related to harmonic detection schemes [37], methods based on positive feedback [54], signal processing and artificial intelligence-based algorithms [55]. For the first group, it is possible to reduce the FDZ by increasing the detection threshold. The main drawback, however, is the growing of the NDZ. For the second group, it is necessary to perform a critical analysis of the inverter stability in order to determine the maximum positive feedback gain that does not lead the inverter operation to instability. Finally, for the last set of AIPs, the FDZ problem can be solved by enlarging the training data set or the number of input features.

### G. QUALITY FACTOR

The load quality factor is defined as the ratio between the storage and the consumed energy of a system. As aforementioned, it can also be defined as a function of the three load parameters according to (7). In order to better understand the effects of the quality factor on the islanding detection, it is important to understand the frequency response of a parallel RLC circuit. In this sense, the general transfer function of the equivalent impedance of a generic RLC parallel load is given by (12) [56]. Figure 2, in its turn, illustrates the magnitude and phase bode diagram of the transfer function described by (15).

$$Z_{RLC}(s) = \frac{RLs}{RLCs^2 + Ls + R} \quad (15)$$

As it is possible to notice that the bigger is the quality factor, the bigger is the attenuation for signals out of the cut frequency. In this way, insertion harmonic-based methods can incur in NDZ cases for high quality factors due to the load filtering capabilities. More than that, AIP strategies based on the monitoring of frequency can be highly influenced by the high quality factors as reported in [57], [58], once it increases the selectivity of the circuit.

### H. MULTI-DG EFFICIENCY

In the literature is relatively common to find papers that analyze the performance of AIP schemes in a single DG environment. However, attesting the correct efficiency of a protection scheme for one islanded inverter does not guarantee that the AIP method will be able to diagnosis islanding if the electrical island contains more than one inverter. This problem is specially related to the active solutions. As their philosophy of operation is based on the insertion of some

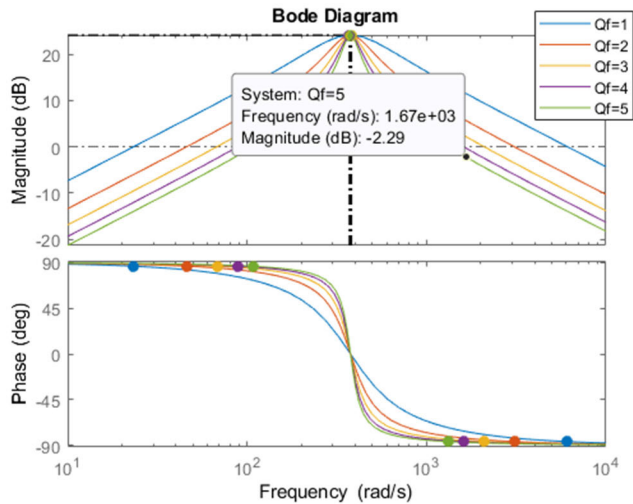

**FIGURE 2.** Bode diagram of a parallel RLC load with multiples quality factors and resonance frequency at 60 Hz.

disturbance in the PCC parameters, in a multi-DG islanding the perturbations injected by each inverter unit can be mutually cancelled, affecting the detection capability. This problem is duly described for harmonic based methods [59], [60] and active frequency drift methods [61].

### I. STABILITY CONCERNS

In general, passive AIP does not insert any disturbance on the operational inverter parameters and, therefore, their operation is not linked to any converter stability concern. The same considerations can be generalized for the remote techniques and for those that do not insert any disturbance on the PCC variables. The hybrid and the active solutions, by the other hand, are inherently linked to perturbation insertion and, therefore, have the potential to negatively impact inverter stability, especially those that use positive feedback [62], [63].

### J. CYBER SECURITY

Remote AIP depends on the use of communication channels or internet connection. This approach brings several advantages for islanding detection related to reliability and accuracy. However, the use of communication lines creates problems related to cyber security. In this context, a hacker attack can lead to false data injection or real data replication, provoking a false positive islanding diagnosis.

## IV. ANTI-ISLANDING METHODS

An anti-islanding method refers to any algorithm or physical relay that can detect a loss of mains event and interrupt the islanded operation within the time period required by the cited standards. There are six categories of strategies proposed in the literature to tackle the islanding phenomenon, including remote, passive, active, hybrid, machine learning, and signal processing-based approaches. This section

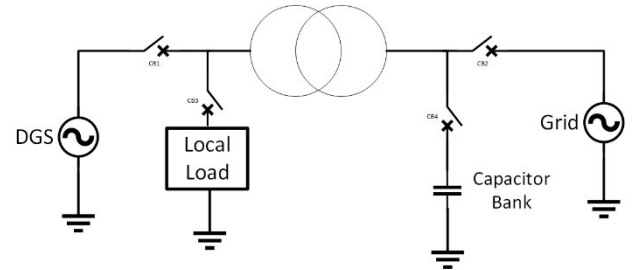

**FIGURE 3.** General representation of the impedance insertion AIP.

will cover each of these categories, discussing their main approaches and the corresponding timeline of evolution.

### A. REMOTE TECHNIQUES

The remote or grid-resident AIP strategies are defined by the use of communications or signal processing technologies in to perform islanding detection. The adoption of remote AIP is justified as it avoids several drawbacks related to the local AIP such as losses of effectiveness in the multi-DG islanding, impact on the power quality and the existence of the NDZ. However, remote islanding detection suffers with high-cost and complex implementation, and, therefore, it is economically impractical for small or medium DGS. The main representative remote strategies are Power Line Carrier Communication (PLCC), Direct Transfer Trip (DTT) and, External Capacitor Switching (ECS) [5].

#### 1) IMPEDANCE INSERTION

The Impedance Insertion method is based on the switching of some kind of impedance, generally a capacitor bank, in to create a reactive power mismatch and deviate the frequency of the PCC voltage to out of the allowed range of operational values. The general representation of this AIP scheme is shown in Figure 3. The main disadvantages of this strategy are: the price of a capacitor bank, the low response time and the possibility of incurring in NDZ [6]. This method was widely applied at the first AIP analysis on the Rokko Test Center, in studies dating back to the 1990s [64], [65]. However, the necessity of an extra device connected at the PCC and the consequent high cost of its implementation discourage its application.

#### 2) DIRECT TRANSFER TRIP (DTT)

In the Direct Transfer Trip (DTT) based anti-islanding strategies, the central main monitors all breakers capable of isolating the DGS, determining which areas are islanded [3]. This scheme has the same advantages than other remote AIP techniques, i. e. high effectiveness and accuracy, but it also suffers with the high cost and complex implementation, since it depends on communication infrastructure such as leased phone lines, radio or dedicated fiber and also requires a supervisory system [8].

In [66] was performed a study about three naturally occurring islanding events in a power plant with hydraulic, natural

gas and wind-based generators that applied the DTT scheme to perform protection against islanding. The analyzed data suggests that the DTT scheme should be avoided in systems with load-shedding capabilities in order to avoid high detection times. Beyond that, its performance can be seriously affected by reactive compensators.

### 3) POWER LINE CARRIER COMMUNICATION (PLCC)

A PLCC is defined by the presence of a transmitter (T) at the utility grid side and a receiver (R) that communicates using the power line itself. Generally, the islanding signal is sent during four conduction cycles and the grid interruption diagnosis is performed if the signal disappears during this time [67]. PLCC-based AIP schemes require repeaters for communication lines longer than 15km in to avoid signal attenuation [5]. Due to high complexity and implementation cost, the method was targeted by few publications in the literature.

The use of a PLCC to detect islanding was first proposed in [7]. This work has made significant contributions for understanding the importance of selecting an appropriate transmitted signal, as high frequency signals are attenuated by the series inductors of the distribution transformers and must be avoided, particularly for small generation systems. Beyond that, the information transmitted must be very slow to reduce complexity. In addition, it uses a commercial automatic meter reading and a self-made low-cost receiver to avoid extra implementation expenses and also provides a set of requisites that must be accomplished by a PLCC-based AIP strategy to reach economic feasibility.

In [68] is proposed a performance analysis of a PLCC-based AIP on a real distributed generation system. This work presents a series of conclusions about the attenuation of the sent signal in virtue of natural features of the line, such as the length, the cables constituted material and the local loads characteristics. In [69] is studied the sent signal attenuation provoked by a medium voltage transform and the mathematical expression of this attenuation is derived. Finally, [70] performs a sensitivity analysis of a PLCC AIP scheme.

### 4) SUPERVISORY CONTROL DATA ACQUISITION APPROACH (SCADA)

A Supervisory Data Control Acquisition (SCADA) is defined as a data acquisition system that allows remote control of industrial processes [11]. This system monitors several breakers, including the switches responsible for the interconnection between the DGS and the main grid. Therefore, it can be successfully applied for performing the islanding detection. The scheme presents the same advantages and drawbacks of other remote techniques. This way, this method is able to eliminate the NDZ without demanding any power quality degradation. However, the high complexity, cost and necessity of remote operators make SCADA based AIP unfeasible for small or medium DG [71].

### 5) PHASE MEASUREMENT UNIT APPROACH

A Phasor Measurement Unit (PMU) provides real time data of phase and magnitude of an electrical phasor of the electrical system [72]. PMU has been utilized in various applications within power systems, including synchronization, monitoring, intentional islanding maneuver, and unintentional grid interruption detection at the transmission voltage level.

In relation to the intentional islanding maneuvers, [73] provided a complete analysis of an intentional islanding of an 80 MW power plant connected to a 132 kV transmission line connected to an urban substation. The collected results demonstrated that the PMU device performed a reconstruction of the analyzed signals with low amplitude and phase errors. Furthermore, the study concluded that PMU devices are capable of providing a more reliable representation of transient frequency, power, positive sequence voltage, and phase variations compared to SCADA systems.

On the other hand, PMU is also employed to perform unintentional islanding detection. In [74] is proposed two different PMU AIP schemes: Frequency Difference Method (FDM) and Change of Angle Difference Method (CADM). The first one conducts the loss of mains detection through the comparison of the measured frequency with a preset value. The second approach, on its hand, uses the phase difference between two buses. The results showed that both methods were able to perform islanding detection for three different contingencies. More than that, it is analyzed that the combination of FDM and CADM were sufficiently selective to avoid the false tripping of the DGS under 6 non-islanding occurrences.

In [75] is proposed a new detection strategy composed by a PMU system that uses an intelligent tree algorithm to perform the loss of mains diagnosis in a wild area electrical system. The results demonstrated a 98% of effective in islanding detection. In [9], is presented Synchro phasor-AIP using Systematic Principal Component Analysis (SPCA) that presents good performance with or without updating training data. In [76] is proposed a remote technique that amalgamates the PMU and the SCADA approaches. The results indicate corrected islanding performance with no misclassification cases. Other successful unintentional islanding detection schemes using PMU based techniques are described in [77] and [78].

### 6) MICRO PHASE MEASUREMENT UNIT (MPMU)

The concept of Micro Phasor Measurement Unit (MPMU) was firstly proposed in [79] as a means to provide accurate real-time data for supervisory, control, or protection systems at distribution voltage levels. These units are designed according the specific characteristics of distribution lines, such as multiple nodes, short distances, small amplitude and angle differences between nodes, faster dynamics, and a lack of standard documentation [80].

In [10] is presented a MPMU based AIP scheme based on the monitoring of two features: Cumulative Sum of Frequency Difference (CMFD) and Phase Angle difference

(PAD), exploiting, therefore, the influence phase affects in frequency after the loss of sources. This method uses a Pearson correlation coefficient in order to detect the islanding event. The results show that the system is able to detect islanding correctly within 0.25 seconds when there is a 0.01 Hz frequency deviation, while being immune to measurement noise and capable of distinguishing non-islanding contingencies.

In [81] is proposed a new MPMU AIP that depends on four MPMU devices connected to different buses of the electrical system. It uses six parameters in order to detect the grid interruption: voltage magnitude, phase angle, ROCOV, frequency, ROCOF, voltage phase difference and ROCPAD. These features are sent to a central controller formed by logic gate arrays that diagnose the islanding event. The results indicated the capability of detecting islanding in power balance conditions and selectivity regarding to non-islanding events.

One of the main drawbacks of MPMU based AIP refers to the possibility of cyberattacks due to communication systems and data exchange over the internet. This problem is addressed in [82], that proposes an entire sub channel dedicated to the islanding detection. This approach presents immunity to the following cyberattack types: cables physical obstruction, data replication, false data injection, network traffic obstruction.

### B. LOCAL PASSIVE TECHNIQUES

Passive Islanding Detection (PID) is a generic classification for a huge set of AIP schemes based on the pure monitoring of some PCC variable. The principal advantage of this approach lies in the fact that PID does not insert any kind of disturbance or impact on the power quality. However, PID has an important drawback in terms of reliability due to its large NDZ and poor detection speed. The main examples of this category include under/over voltage (OUV) or frequency (OUF), Phase Jump (PJ) detection, Harmonic Distortion (HD) detection, Rate of Change of Frequency (ROCOF), Rate of Change of Voltage (ROCOV), Rate of Change of Phase Angle Difference (ROCPAD), Rate of Change of Active Power (ROCOP), and Rate of Change of Reactive Power (ROCOPR) [37].

#### 1) OVER/UNDER VOLTAGE (OUV) AND FREQUENCY (OUF)

The OUV/OUF scheme is based on the monitoring and comparison of instantaneous values of, respectively, voltage magnitude and frequency with the standardized thresholds and the inverter shutdown occurs when the method detects an abnormality during a preset time interval. This is certainly one of the simplest PID schemes, once frequency and voltage relays are inherently present in commercial inverters. According to the “IEEE Standard for Electrical Power System Device Function Numbers, Acronyms, and Contact Designations” [83], which aims to define codes for protection, monitoring, and control devices, the frequency monitoring device is assigned the ANSI 81 code, while the over and under voltage relays are assigned the ANSI 59 and ANSI 27 codes,

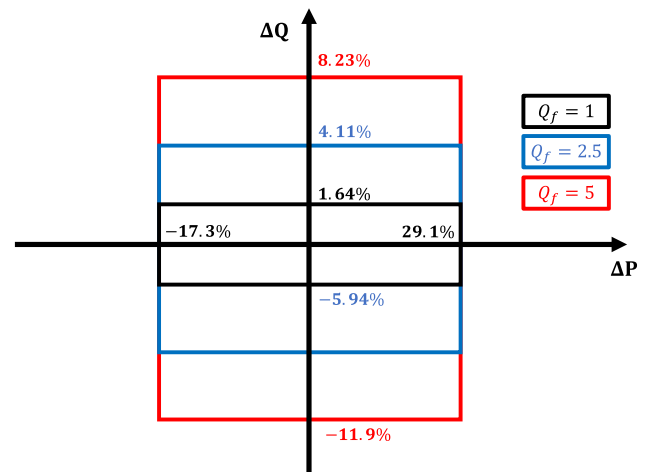

FIGURE 4. OUV/OUF NDZ for different values of quality factor.

respectively. Mathematically, the NDZ of this method can be plotted in the  $\Delta P \times \Delta Q$  plan using (16) and (17).

$$\left(\frac{V}{V_{max}}\right)^2 - 1 \geq \frac{\Delta P}{P_{DG}} \geq \left(\frac{V}{V_{min}}\right)^2 - 1 \quad (16)$$

$$Q_f \left(1 - \left(\frac{f}{f_{min}}\right)^2\right) \geq \frac{\Delta Q}{P_{GD}} \geq Q_f \left(1 - \left(\frac{f}{f_{max}}\right)^2\right) \quad (17)$$

Figure 4 displays a graphical representation of the region, taking into account both the maximum and minimum frequency thresholds specified by IEEE 929-2000. The figure also illustrates the impact of load quality factor in the NDZ size.

The  $\Delta P$  axis refers to the voltage variation, and the  $\Delta Q$  axis refers to the frequency variation. As one can see, the voltage variation is not sensitive to variation of the quality factor. The frequency variation, on the other hand, is highly impacted by the  $Q_f$  value, the bigger is  $Q_f$ , the bigger is the NDZ.

In order to illustrate algorithm NDZ, Figure 5 shows the current, PCC voltage and frequency results of the OUF/OUV AIP strategy, after an islanding event for  $C_{norm} = 1.02$ . It is possible to conclude that this method is not capable of deviating the frequency nor the RMS value of the PCC voltage out of the range of allowed values of operation and, therefore, the inverter is not able to detect the islanding occurrence.

#### 2) PHASE JUMP DETECTION (PJD)

This AIP strategy monitors the angle difference  $\theta_{inv}$  between the voltage and the inverter output current that can abruptly change after grid interruption, especially under power unbalance conditions.

This strategy can be faster than the OUV/OUF approach, as phase dynamics change more quickly than frequency under certain conditions [16]. However, it is important to state that the modern Phase-Locked Loop (PLL) algorithms have improved the robustness of the synchronization between the PCC voltage and inverter current and, therefore, the phase

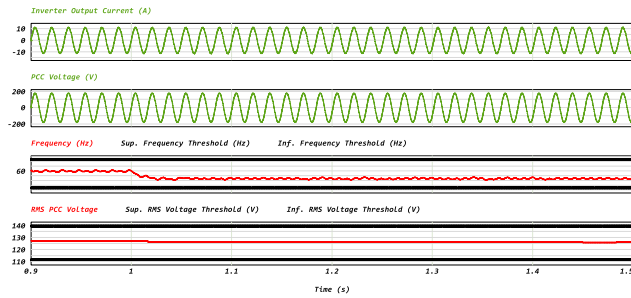

FIGURE 5. OUV/OUF current, voltage and frequency results for a NDZ case.

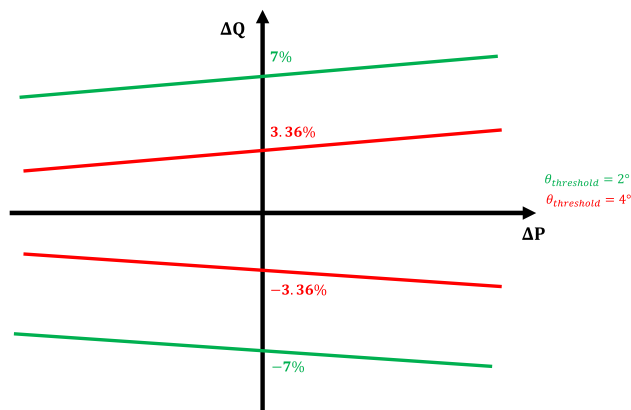

FIGURE 6. PJD NDZ for different values of threshold.

jump can be quickly absorbed, avoiding islanding detection. Another drawback related to its implementation is the choosing of a correct threshold to diagnose the grid disconnection. This is due because differently of voltage frequency and magnitude, there is no standardized recommendation for the phase jump [12]. Moreover, the PJD can lead to false tripping, as soon as the starting of motors and the switching of a capacitor bank can cause a transient change in the PCC voltage phase [84].

Lastly, it is necessary to analyze the NDZ problem of the PJD method, mathematically described by (18).

$$abs\left(\arctg\left(\frac{\frac{\Delta Q}{P}}{\frac{1+\Delta P}{P}}\right)\right) \leq \Theta_{threshold} \quad (18)$$

As one can see, the NDZ is not affected by the quality factor of the local load, however it is highly dependent on the chosen threshold. In this sense, Figure 6 illustrates the NDZ for the PJD for different values of the angle detection threshold. It is possible to notice that differently of the OUFV scheme, the PJD one presents NDZ for all values of the ΔP.

### 3) HARMONIC DETECTION (HD)

This method is based on the constant monitoring of the harmonic content of the PCC voltage. During the normal operation, the THDv is determined by the interaction between the harmonic components of the inverter output current and

the grid impedance. After the grid interruption, the THDv is determined by the product of the harmonic components of the inverter output current and the load impedance, which can be significantly higher than the grid impedance [84].

The main advantage of this strategy lies on its non-dependency of the power unbalance of generated and consumed power [47]. However, its implementation is marked by the difficulty of the protection relay parametrization. In this sense, a small islanding threshold can lead to the inverter false tripping and a big one, on the other hand, can lead to the increasing of the NDZ. In addition, it is important to note that the algorithm lacks selectivity, once several non-islanding contingencies can impose an increasing of the THDv [85]. Non-linear loads [86] and the grid background distortion [87] also impact the method performance. Lastly, the capacitance of the local loads can filter high frequency harmonic components and, therefore, mitigate the scheme efficiency.

Several papers have proposed HD-based AIP schemes in order to guarantee more robustness, efficiency and selectivity and correct the above-mentioned drawbacks. In this scenario, some strategies interlock the HD with other passive parameters to improve selectiveness. In [88], [89], and [90], for instance, are proposed passive AIP strategies that combine the harmonic measurement with an unbalance phase voltage relay. The results showed that the proposed solution reached correct islanding detection to balance and unbalance load conditions. Moreover, it was capable of distinguishing between islanding and non-islanding events. In [91] is proposed a hybrid solution that exploits the Gibbs phenomenon in parallel with the THDv. The performed tests proved the solution is efficient to detect the islanding formation in a multi-DG system, with less NDZ than passive versions of HD and less harmonic content than active AIP strategies.

Other solutions detect islanding based on specific harmonic components. In [92] is proposed a HD strategy based on the use of Kalman filter to evaluate the energy density of the third and the fifty harmonic components. In [93] is proposed an AIP solution based on the PWM harmonic signature of the inverter. In the study by [94], a HD passive islanding detection method based on the even harmonic components of the PCC voltage was proposed. The results proved that the scheme is able to perform the grid interruption detection for a multi-DG system. Finally, in [95], the islanding detection is obtained by applying a Discrete Fourier Transform to extract the second harmonic order of voltage and current.

### 4) RATE OF CHANGE OF FREQUENCY (ROCOF)

The Rate of Change of Frequency (ROCOF) is a passive AIP based on the measurement of the frequency derivative. Equation (19) shows the general expression of the ROCOF calculus. It is important to mention that the frequency derivative over time is influenced by some of the physical characteristics of the DGS. In this sense, inertia, nominal frequency, rated power and by the amount of active power supplied by the

main grid in the moment of the islanding, according to (20) [96].

$$ROCOF = \frac{1}{n} \sum_{k=1}^n \frac{df}{dt} (k) \quad (19)$$

$$\frac{df}{dt} = \frac{\Delta P}{2HG} f \quad (20)$$

where H represents the system's inertia constant, and G represents the system's damping coefficient.

The technique can be implemented with a Cross-Zero Detector (CZD), a Fast Fourier Transform (FFT) [97], a Phase Locked Loop (PLL) [98], with an Interpolated Discrete Fourier Transform and a Kalman Filter [33] or with Phasor-Measurement Units (PMU) [99].

One of the main challenges of the ROCOF AIP is the determination of the measuring window in which the ROCOF will be computed and the correct threshold for the islanding detection. In this context, [96] states that the time interval must figure in the interval of 0.3 to 0.7 s and the detection threshold is fixed in 0.3 Hz/s. Beyond that, [100] also proposes a setting methodology for ROCOF relays based on a field study of a biomass generation plant. Another issue of the strategy implementation is the difficulty of coordinating the ROCOF relay with other frequency protection devices. In this sense, [14] proposed a graphical design methodology to guarantee the coordination between the OUF relay with the ROCOF one.

Another serious ROCOF drawback is its susceptibility to nuisance trips after non-islanding events. Thus, several works tried to mitigate this problem through the combination of ROCOF with the measurement of another electrical variable. In [97], is proposed an under voltage interlock function to distinguish the grid interruption to transient contingencies like voltages dips. In [101], the actuation of the ROCOF protection is locked with the value of the THDi. In [102], it is presented an interlacing of ROCOF with the estimation of the grid impedance. Finally, in [103] is proposed an enhanced version of the ROCOF relay based on the adaptive Kalman filter estimation method. This solution has capability of distinguishing the grid interruption of other electrical contingencies once it reduces the sensitization of the relay for non-islanding faults.

On the other hand, the ROCOF approach offers important advantages. One of them is its portability, once the scheme can be used in PV systems [104], in Synchronous Generator based systems [102] or in different types of microgrids [105] with accuracy. More than that, several active AIP are implemented with the ROCOF relay in order to accelerate the grid interruption detection: [106] presents a combination of SMS and ROCOF; [19] presents a hybrid method combining SFS and ROCOF; [107] presents a RPV based AIP implemented with a ROCOF relay. There is also an active ROCOF relay, proposed in [108].

Differently of other passive solutions, the literature about the ROCOF strategy lacks an analytical determination of its

NDZ. However, diverse works tried to stipulate the boundaries of the NDZ through computational or experimental evaluations. In [109], for instance, it was proposed a computational study for the mapping of the non-detectable region through different RLC loads, with multiple values of quality factor and for PV systems with different inertial constants. The results showed the dependence of the NDZ on two primary factors: load quality factor and contributions of active and reactive power flowing from the grid to the PCC. In [13], in turn, is proved that the combination of the ROCOF with the ROCOV relay, has a smaller NDZ compared to the combination of the OUF and OUV. In [110], an extensive computational study is conducted to determine the maximum boundary of the ROCOF NDZ.

#### 5) RATE OF CHANGE OF VOLTAGE (ROCOV)

This method is based on the determination of the Rate of Change of Voltage (ROCOV), since the grid interruption can provoke a transient deviation of the PCC voltage [15]. Mathematically, the general expression of the algorithm implementation is given by (21).

$$ROCOV = \frac{\Delta (V_n - V_{n-1})}{\Delta t} \quad (21)$$

It is important to state that ROCOV can be used either to diagnose islanding or other electrical contingencies and is especially common to perform fault detection in High Voltage Direct Current (HVDC) systems [111], [112] or in DC microgrids [113]. This scheme is also able to perform the loss of main detection in AC microgrids, as reported in [114]. Beyond that, ROCOV can be used in parallel with other AIP. In [115], for instance, is proposed a hybrid strategy based on the combination of the ROCOV measurement and the Rate of Change of Active Power (ROCOAP) capable of performing islanding detection in a multi-DG environment.

It is necessary to state that in [116] it is concluded that ROCOV relays are superior in selectiveness and reliability to the conventional current and voltage protection devices. Finally, [117] proposes a coordination scheme for microgrids based on the ROCOV measurement.

#### 6) RATE OF CHANGE OF PHASE ANGLE DIFFERENCE (ROCPAD)

This method was proposed in [118] and is based on the constant monitoring of the Rate of Change of the Phase Angle Difference (ROCPAD) between the inverter output current and voltage and the determination of the variation rate of this quantity over time. Mathematically, the rate of change of the phase angle difference can be determined by (22). Reference [119] proposed a passive AIP that mixes ROCOF, ROCOV and ROCPAD to reduce NDZ.

$$ROCPAD = \frac{\Delta (\theta_{inv})}{\Delta t} \quad (22)$$

### 7) OTHER RATE OF CHANGE BASED-METHODS

As aforementioned, the islanding occurrence can generate abrupt and transient deviation of several electrical variables. Frequency and voltage are the most common and, therefore, they have a special subsection in this section. However, the literature has described other rate of change based relays such as: Rate of Change of Power (ROCOF) [120], Rate of Change of Reactive Power (ROCORP) [121], Rate of Change of Frequency over Power (ROCOFoP) [122] and Rate of Change of Voltage over Power (ROCOVOP) [22]. More than that, in [123] is proposed a combination of ROCOP and ROCOQ.

### 8) VOLTAGE UNBALANCE

Voltage unbalance is a phenomenon that occurs when three-phase system experiences different amplitudes of voltage or phase delays that are different from 120 degrees. This can be caused by various factors, such as heavy single-phase loads switching on and off, lack of symmetry in transmission lines, single-phase short circuits, and other issues. Additionally, islanding operations can also lead to voltage unbalance if the loads in each phase have different magnitudes or impedances.

In [88], for example, the voltage unbalance is used for interlocking the islanding analysis with the harmonic measurement, as it was aforementioned. A similar strategy was proposed in [89]. It uses the voltage unbalance in parallel with the measurement of the fifteenth harmonic order to improve the capability of distinguishing islanding and non-islanding events. Moreover, some hybrid methods used the voltage unbalance as the passive stage of their operation. These schemes will be carefully analyzed in the section related to the hybrid tactics.

### C. LOCAL ACTIVE TECHNIQUES

As aforementioned, passive AIP solutions lack reliability when exists a balance between the power generated by the DGS and the power demanded by the local loads. Thus, the need of correcting the passive AIP NDZ issues created the active anti-islanding solutions, characterized by the insertion of some perturbations in the inverter operation in order to deviate the point of operation to out of the Standards thresholds. Although the actives solutions are inherently marked by the power quality degradation, its adoption is justified due to the mitigation of the NDZ [18].

#### 1) ACTIVE FREQUENCY DRIFT (AFD)

The Classic AFD was proposed by [124] and inserts a dead time at the end of each semi-cycle, according to Figure 7. Its operating principle involves inserting a dead time at the end of each semi-cycle, creating a phase difference between the PCC voltage and inverter current output while maintaining synchronism at the zero crossing. The Classic AFD algorithm parametrization depends on the choice of the value of the chopping factor ( $c_f$ ), defined as the ratio of twice the dead time  $t_z$  to the nominal period (T), according to (23). Mathe-

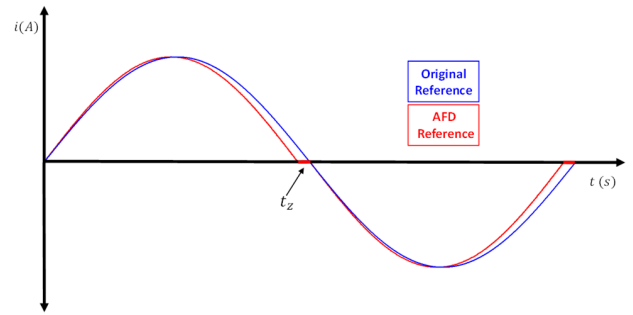

FIGURE 7. AFD reference.

matically, the waveform exposed in Figure 7, is given by (24).

$$c_f = \frac{2t_z}{T} \quad (23)$$

The main advantage of the AFD solution lies on its implementation simplicity. However, it is necessary to highlight that this algorithm has several drawbacks: lack of efficiency in multi-DG islanding, high levels of THDi and serious NDZ issues. Other operational limitation is related to the fixed value of  $c_f$ . This fact, in turn, leads to a problem related to the frequency drifting tendency generated by the load. For instance, when the  $c_f$  is positive, the frequency tends to drift to values higher than the nominal grid frequency, and more inductive loads generate a tendency to drift the frequency to less than the nominal grid frequency. This load frequency drifting tendency can cancel out the deviation frequency imposed by the AIP, resulting in a failure of grid interruption detection.

$$i_{afd}(t) = \begin{cases} I \sin\left(2\pi\left(\frac{f}{1-c_f}\right)t\right), & 0 < \omega t \leq \pi - t_z \\ 0, & \pi - t_z < \omega t \leq \pi \\ I \sin\left(2\pi\left(\frac{f}{1-c_f}\right)t\right), & \pi < \omega t \leq 2\pi - t_z \\ 0, & 2\pi - t_z < \omega t \leq 2\pi \end{cases} \quad (24)$$

In order to illustrate the algorithm NDZ, Figure 8 shows the current, PCC voltage and frequency results of the AFD AIP strategy, after an islanding event for  $C_{norm} = 1.05$  and  $c_f = 0.035$ . It is possible to conclude that this method is not capable of deviating the frequency for out of the range of allowed values of operation and, therefore, the inverter is not able of detecting the islanding occurrence.

#### 2) IMPROVED ACTIVE FREQUENCY DRIFT (Iafd)

In order to correct the THDi problem of the Classic AFD, [125] proposed the Improved Active Frequency Drift (Iafd) algorithm. Instead of inserting a dead time, IAFD replaces it with a step on the current magnitude during the odds quarter-cycles of current, as shown in Figure 9. The waveform described by Figure 9 is given by the system of equations (25).

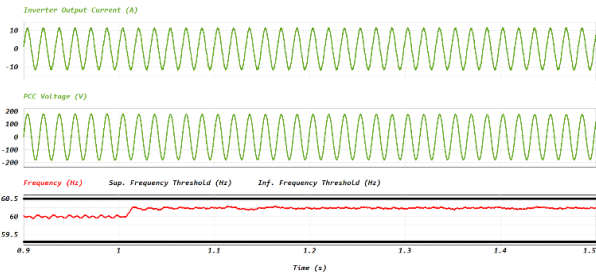

FIGURE 8. AFD current, voltage and frequency results for a NDZ case.

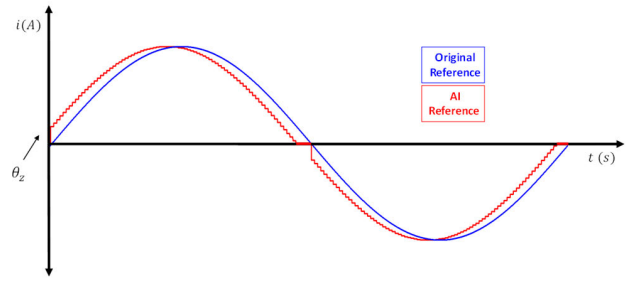

FIGURE 10. AFD by [128] current reference.

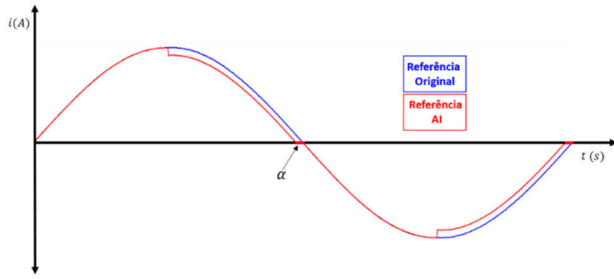

FIGURE 9. IAFD reference.

Analytically, is possible to conclude that the value of the parameter  $K$  can determine the level of intrusion this algorithm will perform. The bigger is  $K$ , the bigger will be the detection capability, however, the bigger will also be the harmonic content of the output current. Beyond that, the  $K$  gain also influences the determination of the NDZ, once it creates a phase difference between the PCC voltage and the inverter output current expressed by (25).

$$i_{iafd}(t) = \begin{cases} I_{sen}(2\pi ft), & 0 < \omega t \leq \frac{\pi}{2} \\ I_{sen}(2\pi ft) - KI, & \frac{\pi}{2} < \omega t \leq \pi - \arcsin(K) \\ 0, & \pi - \arcsin(K) < \omega t \leq \pi \\ I_{sen}(2\pi ft), & \pi < \omega t \leq \frac{3\pi}{2} \\ I_{sen}(2\pi ft) + KI, & \frac{3\pi}{2} < \omega t \leq 2\pi - \arcsin(K) \\ 0, & 2\pi - \arcsin(K) < \omega t \leq 2\pi \end{cases} \quad (25)$$

### 3) AFD BY [126]

In [126] is proposed another variant of the Classic AFD, marked by the insertion of a small phase jump on the beginning of each semi-cycle of current, as illustrated by Figure 10. Mathematically, the waveform described by Figure 10 can be represented by (26).

$$i_{afd}(t) = \begin{cases} I_{pic} \times \sin(2\pi ft + \theta_z); & 0 < \omega t \leq \pi - \theta_z \\ 0; & \pi - \theta_z < \omega t \leq \pi \\ I_{pic} \times \sin(2\pi ft - \theta_z); & \pi < \omega t \leq 2\pi - \theta_z \\ 0; & 2\pi - \theta_z < \omega t \leq 2\pi \end{cases} \quad (26)$$

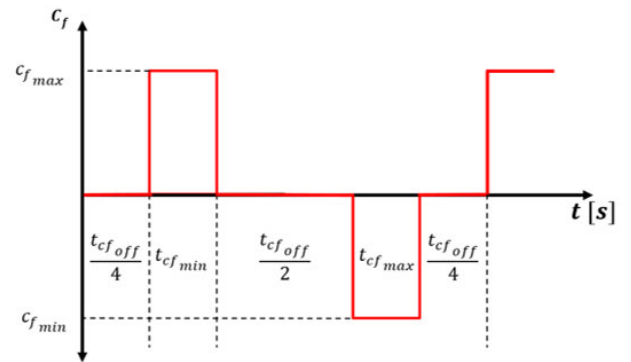

FIGURE 11.  $c_f$  behavior over time.

### 4) AFD WITH PULSATING CHOPPING FACTOR (AFDPCF)

As it was above mentioned, the Classic AFD is not able to follow the frequency drifting tendency imposed by the local loads. In this sense, [127] proposed the AFDPCF that changes the fixed value of  $c_f$  by a pulsating signal, alternating in positive, zero and negative values according to (27). Figure 11, by its turn, illustrate the  $c_f$  pulsating function over time.

$$c_f = \begin{cases} c_{fmax}; & \text{if } T_{cmaxon} \\ c_{fmin}; & \text{if } T_{cminon} \\ 0; & \text{if } T_{coffon} \end{cases} \quad (27)$$

The main advantage of this method consists in the reduction of the injected THDi due to the conduction periods in which  $c_f = 0$ . More than that, the alternation between positive and negative  $c_f$  values helps the algorithm to detect the islanding independently of the direction of the frequency deviation imposed by the local loads.

Finally, the AFDPCF algorithm is capable of eliminating the NDZ for a series of values, as demonstrated in [46]. In [46] was also proposed a design methodology for the AFDPCF implementation that calculates the values of  $c_{fmax}$  and  $c_{fmin}$  for eliminating a given range of quality factor values. This design methodology is expressed by (28).

$$c_f = \begin{cases} c_{fmax} = \frac{2.4Q_f}{f_0\pi} \\ c_{fmin} = -c_{fmax} \end{cases} \quad (28)$$

However, the main drawback of the algorithm is its longer detection time compared to other methods. As explained in [46], there is no synchronization between the change of the  $c_f$  value and the moment of the grid interruption. In this scenario, if the islanding occurs when  $c_f = 0$ , the method will only be able to perform the frequency drift after the changing of the  $c_f$ . An alternative version of the AFDPCF is given in [128].

### 5) SANDIA FREQUENCY SHIFT (SFS)

The SFS algorithm was proposed by [124] and aims to correct the operational problems of the Classic AFD algorithm through the adoption of a variable chopping factor linked to the measured frequency error, according to equation (29). The distortion inserted into the inverter output current creates a phase difference between the inverter output current and the PCC voltage, as illustrated by (30).

$$c_f = c_{f0} + K (f_{pll} - f_n) \tag{29}$$

$$\theta_{inv} = \frac{\pi(c_{f0} + K (f_{pll} - f_n))}{2} \tag{30}$$

The main advantages of the SFS method lie on the reduction of the THDi rates and of the detection time. During grid tie operation, the PLL measures a frequency that is nearly identical to the nominal grid frequency. As a result, the difference between  $f_{pll}$  and  $f_n$  ( $f_{pll} - f_n$ ) is very low, leading to a low value of  $c_f$  and, consequently, a low THDi rate in the inverter output current. However, in the event of a grid interruption, the frequency drifts away from the nominal value, causing an increase in  $c_f$ . This deviation in frequency further amplifies  $c_f$ , creating a vicious cycle that reduces the detection time.

As it can be seen, the SFS design depends on two parameters:  $c_{f0}$  and the accelerating gain  $K$ . While the  $c_{f0}$  affects the THDi rate, the gain  $K$  determines the NDZ size [129]. Thus, the SFS implementation goals to accomplish the maximum possible NDZ reduction with the minimum injected THDi. In this scenario, several design methodologies have been proposed. In [57], for instance, is proved that, for a  $K$  designed according to (31) the method is capable of eliminating the NDZ for a range of  $Q_f$  that goes from 0 to the chosen value of

$$K > \frac{4Q_f}{\pi f_0} \tag{31}$$

However, the NDZ of the SFS algorithm can be influenced by the number of inverters connected to the same PAC, deteriorating its detection capability. In order to address this drawback, [130] proposed a new design methodology for the SFS scheme in order to guarantee the optimal tuning of the SFS even in the multi-DG case. Computational simulations were successfully carried out; however, no experimental validation was provided.

On the NDZ problem, [131] carried out a dynamical study about the influence of the parameters  $c_{f0}$  and the accelerating gain  $K$  on the NDZ mapping and size. It was concluded that  $K$  has a direct impact on the range of  $Q_f$  values for which the

NDZ is eradicated, thus the increasing of  $K$  reduces the NDZ size. On the other hand,  $c_{f0}$  determines the value of the  $C_{norm}$  at the initial point of the NDZ. In this sense, the growing of  $c_{f0}$  leads to the increase of the  $C_{norm}$ .

Nevertheless, the stability study conducted in [54], showed that high values of  $K$  can impact on the converter stability, leading to false tripping, especially in weak grids or for large size DGS. In this scenario, [132] proposed a SFS variation based on the concept of the pulsating initial chopping factor, similar to the AFDPCF algorithm. The fixed value of  $c_{f0}$  is replaced by a pulsating signal that alternates its value according to (32). Thus, it is possible to set  $T_1$  and  $T_2$  to match the time required for each  $c_{f0}$  value to detect the islanding event.

$$c_f = \begin{cases} c_{f0} = 0.05; K = 0.03, & \text{if } T_1 \\ c_{f0} = 0; K = 0.03, & \text{if } T_2 \end{cases} \tag{32}$$

Another parametrization approach is the use of machine learning and artificial intelligence techniques to perform the properly choosing of  $c_{f0}$  and  $K$ . In [133], for instance, the SFS parametrization is conducted by an adaptive fuzzy logic-based algorithm that estimates the local load parameters and determine the lowest value of  $K$  that eliminates the NDZ based on the estimated parameters. In [134], on the other hand, the parametrization is made by a immune system based machine learning algorithm. The experimental realization achieved superior results in terms of THDi and detection time in a PV and a wind power DG system.

### 6) SLIP MODE SHIFT (SMS)

The Slip Mode Frequency Shift (SMS) is based on the insertion of the a small disturbance in the phase estimated by the PLL through a frequency positive feedback according to (33) [47].

$$\theta_{SMS} = \theta_M \sin\left(\frac{\pi (f - f_i)}{2 f_i - f_m}\right) \tag{33}$$

The biggest advantages of this AIP scheme are: the capability of follow the frequency deviation of the frequency imposed by the load, the easiness of its digital implementation and the elimination of the NDZ for a given factor of  $Q_f$  [106]. In [49] is proposed a comparative study of the influence of the multi-DG islanding on the NDZ of the SMS strategy. The study found that multi-DG operation has a negative impact on its performance, increasing its NDZ.

In [135] is proposed the new Automatic Phase Shift (APS) algorithm that inserts an initial fixed perturbation on the  $\theta_{SMS}$ . In [136] it is proposed a modified APS in which the values of the parameters vary according to the estimation of the impedance of the local load. In [137] is proposed a combination of the SMS with the ROCOF algorithm in order of decreasing the detection time. In [138] is proposed a hybrid AIP based on the combination of the SMS with the Q-f droop curve, this algorithm will be carefully detailed in the next subsection. In [139] is conducted an experimental

comparative analysis where the SMS accomplished faster islanding detection when compared to the SFS scheme.

#### 7) SANDIA VOLTAGE SHIFT (SVS)

The Sandia Voltage Shift (SVS) algorithm is based on the insertion of a disturbance in the current reference of the inverter, promoting a voltage drift in the PCC voltage after the grid interruption in order to detect islanding [37]. The main advantage lies on the possibility of detecting the islanding even on a condition in which the power demanded by the load and the one supplied by the SGD. It is possible to conclude that, once the voltage is less impacted by the reactive power flow of the grid, the method suffers less interference of the reactive load parameters.

On the other hand, the main disadvantages of the SVS are the power quality degradation and the impacts on the inverter stability [63]. In order to diminishes the method drawbacks, [140] proposed a Modified Sandia Voltage Shift (MSVS) that uses an exponential adjustment in the gain of the voltage positive feedback. More than that, the method can be implemented in parallel with the SFS in order of improving the islanding diagnosis capability [141]. In [139], this method was compared to other popular AIP solutions, reaching a correct islanding detection, with small disturbance on power quality. However, this comparative study concluded that SVS algorithm is slower than other AIP solutions such as AFD, SMS and SFS.

#### 8) REACTIVE POWER PERTURBATION (RPV)

In [142] is proposed a new anti-islanding strategy in which the reactive power reference is disturbed in order to create a reactive power unbalance between the inverter and the local load. In [143] is proposed an AIP that uses a Q-f droop curve to set the inverter operation in an unstable operational point after the islanding occurrence. In [144] and [145], are proposed active methods that perturb the q-axis current control in order to deviate the frequency to out of the allowed range of operation. While [144] uses an intelligent control to guarantee faster detection, [145] proposed a solution based on the perturbation of the dq reference frame that is able to guarantee selectiveness and to avoid the inverter tripping for non-islanding contingencies even working under weak grid conditions.

In [146], it is proposed a hybrid anti-islanding method that uses four passive criteria (voltage variation, voltage unbalance, ROCOF and frequency variation) to determine the appropriate timing for inserting the RPV disturbance. In [90], it is proposed a new hybrid algorithm with two passive features: voltage unbalance and THDi and an active bilateral reactive disturbance. This method is a clear evolution in comparison with [146], once it performs the islanding detection with accuracy and lower computational burden, since it demands the measurement of two variables. Finally, in [147] it is proposed a modified Q-f droop curve-based AIP scheme. The experimental validation proved that it is capable

of abolishing the NDZ for a range of  $Q_f$  values, avoid false inverter tripping and presents good performance for the multi-DG islanding.

In [148], it is proposed a bidirectional intermittent RPV based anti-islanding algorithm. In [149], is proposed a new RPV based algorithm whose parametrization is linked to the load's frequency resonance. Although the strategies of [148] and [149] presented good performance, they may not be as effective in detecting islanding in a multi-DG system. Furthermore, both strategies are not suitable for non-unitary power factor inverters. In this scenario, [150] proposed a novel RPV based AIP with the insertion of two sets of reactive power disturbances. The results show that this solution is capable of detecting the grid interruption for both unity and non-unity power factor inverters either in the single or in the multi-DG system.

#### 9) HARMONIC INJECTION

The AIP methods based on Harmonic Injection perturb the inverter current reference with a particular harmonic order, with a specific frequency. After the grid interruption, the correspondent voltage harmonic order will increase with the interaction of the inverter current and the local load impedance. Other popular names for this strategy are: harmonic component injection, impedance at specific frequency, harmonic amplitude jump or high frequency signal injection [37]. The main advantage of this approach lies on its non-dependence of the unbalance between the generated and the consumed power [47]. However, one of the main drawbacks is the chosen of a security threshold to detect the islanding. The method also can incur in NDZ for loads with high filtering capabilities. Beyond that, it can lead to nuisance trips in virtue of the background distortion, instrumentation noises or other non-islanding events.

One of the most common ways of implementing this AIP is by inserting a harmonic component on the PLL reference of current. In this scenario, the paper [151] proposed a new PLL strategy based on the Second Order General Integrator (SOGI). In [17], the same authors proposed an AIP based on the injection of a harmonic signal that can be approximated by a double-frequency oscillation. The experimental results proved that the scheme is able to perform the islanding detection even for a RLC parallel load with  $Q_f < 10$ . In [60] it is proposed an AIP method that inserts a very similar disturbance. However, the measurement of the second harmonic order disturbance is achieved by a Goertzel Algorithm (GA) that reduces the number operation and, consequently, the demanded computational burden. The GA is used also in [152], however, the presented strategy is based on the insertion of the 9th harmonic component. The experimental results showed a good islanding detection performance. Nonetheless, it is necessary to state that the threshold for the 9th harmonic amplitude is of 2% and, therefore, the strategy is more sensitive to inverter false tripping than other methods that use lower harmonics orders [55].

In [153] is proposed an AIP dedicated to three phase inverters that inserts two non-characteristics harmonics of current to measure the grid impedance. This strategy solves the problem of the nuisance trips due to instrumentation noise by applying a digital processing algorithm. Beyond this, it is able to detect islanding even in situations of power balance. In [154] the authors use a subharmonic injection to avoid the disturbance filtering by capacitive loads. The results proved that the method is able to perform the islanding detection for an interval of  $Q_f$  values of  $0.33 \leq Q_f \leq 1.8$  and for  $C_{norm} = [0.95 : 1.05]$  under different levels of inverter active power. In [155], it is proposed an AIP scheme based on the feedback of the rate of change of voltage harmonic in order to diminish the detection time. It also uses a binary tree classification algorithm to avoid the false tripping of the inverter.

The paper [59] detailed studied the problem of the harmonic injection-based methods in a multi-DG system, considering not only the actual configuration of the DGS but also its potential extendibility. It establishes the concept of the Upgrade Factor (UF) that determines the level of extra DER penetration a DGS can support without degrading its islanding detection capabilities. Finally, it also presents a technique based on an external integrator that maximizes the UF and, therefore, increases the reliability of the Harmonic Injection AIP solutions. The compatibility issues of Harmonic Injection schemes in multi-DG systems are also studied in [156] and [157]. According to [156], the compatibility of Harmonic Injection schemes in a multi-DG environment is contingent upon a phase difference falling within the range of  $[-\pi/2; \pi/2]$  between the disturbance inserted by each inverter unit. In response to this challenge, the paper proposes a novel solution that addresses this issue by inserting high frequency current components of negative sequences for both single and three phase inverters. In [157], in turn, this solution is modified to be applied on DGS with grid connected transformers.

Other problem related to the Harmonic injection operation is the complexity of extracting the specific harmonic information. Typically, are employed strategies that demand complex mathematical operations, such as the above mentioned Goertzel algorithm, DFT or machine learning techniques. However, in order to mitigate the computational complexity, some authors presented cross-correlation based schemes. In [158], for instance, is proposed an AIP that detects the grid interruption through the correlation factor between the inserted disturbance of current and the impact it causes on PCC voltage.

Despite its good performance, this strategy lacks an analysis of the impact of the grid parameters and may be subject to flicker problems and interference on the DC voltage control. Finally, in [159] it is proposed a new AIP that introduces a second-harmonic current component and uses a cross-correlation scheme to extract the signal. The use of the correlation explores natural grid characteristics and, therefore, dismiss the monitoring of the injected current. Beyond

that, this scheme has small NDZ and is suitable for Module Integrated Converters (MIC) even with pseudo link DC.

#### 10) NEGATIVE-SEQUENCE CURRENT INJECTION

This approach injects a negative-sequence current in the inverter output in order to create a voltage unbalance between the phases of the system after an islanding event. The main drawbacks are related to the portability, since is an approach only implementable in three phase DGS. Beyond that, it presents problems in multi-DG islanding due to the possible mutual cancellation of the inserted disturbance and in systems with unbalance loads for the same reasons. In [160] it also concluded that the scheme is susceptible to nuisance trip in virtue of load changing, switching of a rotary machine and other non-islanding events.

In [160] is proposed an AIP that injects a negative-sequence current at the inverter output and the islanding diagnosis is performed through the measuring of the negative-sequence voltage at the PCC. The results presented are only referred to computational simulation and indicate the capability of diagnose islanding in 60ms, required an inserted disturbance rate of 2% or 3% of the nominal current. The AIP testing standards are considered, proving the method is insensitive to variations in load parameters. In [161] is determined the NDZ of the solution proposed in [160]. In addition, the paper also proposes a modified algorithm capable of eliminating the non-detectable cases that increases the disturbance magnitude to 5%. In [162] is proposed a sequence negative current injection scheme capable of detecting islanding in a multi-DG environment.

In [163] is proposed a new Negative-Sequence based AIP that inserts positive-feedback disturbance given by (34).

$$I_n = \frac{m \times \sin(\pi * |V_0^-|)}{\lambda} \tag{34}$$

where:

- m – Feedback gain;
- $\lambda$  – width tuning parameter;

The obtained results indicate that the method reduces the power quality degradation when compare to other negative sequence based AIP approaches, works in different grid conditions without the need of parametrization adjustments and does not depend on the  $Q_f$  influence. The biggest drawbacks, on the other hand, lie on the high computational burden and in the low detection time.

Finally, other strategies based on negative sequence injections are presented in [164] and [165]. These solutions are easy to implement, insensitive to load variation and can perform islanding detection for all of the quality factor values of the Standards recommendations. However, their performance can be seriously affected by high penetration of PV inverters and are subjected to nuisances' trips in weak grid conditions.

### 11) MODERN POSITIVE FEEDBACK TATICS

In [129] is proposed a new active anti-islanding technology called Active Phase Jump with Positive Feedback (APJPF) that combines the distortion proposed in [126] with a frequency positive feedback, linking the inserted distortion with the frequency error according to (35). In [46], on the other hand, is carried out a comparative study about the solution proposed in [129] and other schemes. The paper also proposes a parametrization methodology in order to calculate the minimum  $K$  gain in order to guarantee the elimination of the NDZ for a given range of  $Q_f$ , given by (36). The experimental results of [46] indicate an improvement in terms of THDi, detection time and NDZ than: AFDPCF, AFD, AFD by [126] and SFS algorithms for a single DG environment. This AIP method, however, still lacks a multi-DG analysis.

$$\theta_z = \theta_{z0} + K (f_{pll} - f_n) \quad (35)$$

$$\theta_z = \begin{cases} \theta_{z0} = 0 \\ K > \frac{Q_{fAPJPF} + 0.11702}{31.91489} + \sigma \end{cases} \quad (36)$$

where:

- $\theta_{z0}$  – Initial phase jump;
- $Q_{fAPJPF}$  – quality factor at the beginning of the NDZ;

In [166] is proposed a new islanding detection method using phase shifted feed-forward voltage, with operational principle similar to the SMS algorithm, but the phase disturbance is given by (37). The algorithm was tested under a single-DG and a multi-DG environment. The experimental results attested the efficiency of the AIP for different quality factors for both situations.

$$\theta_v = \theta_M \frac{f - f_n}{f_m - f} \quad (37)$$

In [167] is proposed a frequency positive feedback scheme based on the droop curve that inserts a disturbance on the control reactive power reference. The main goal is to deviate the frequency out of the range of the allowed operational values and, consequently, guarantee the correct inverter shutdown after the islanding occurrence. The scheme was tested in 90 different load conditions (different values of quality factor, normalized capacitance and power levels) and reached correct detection for all of the tested cases. However, further experimentation is needed to test the method efficiency in multi-DG systems.

### 12) JEM ALGORITHMS

Japan has instituted specific Anti-Islanding Protection (AIP) algorithms that are required to be integrated into inverters before they are commercially available. Within this framework, Japanese inverter manufacturers adhere to standards such as the JEM 1505 for three-phase power conditioners in solar power generation, utilizing the Step Injection Frequency Feedback Method. Additionally, they comply with the JEM 1498 standard for single-phase solar power inverters in distributed power supply, employing the Frequency Feedback

Method with Step Injection of Reactive Power. In [168], is proposed a detailed performance analysis of the JEM 1505 algorithm under for single and multi-DG environment. Computational results showed the capability of detection the islanding in less than 200ms for one to four inverter in the same PCC. By the other hand, the literature still lacks a detailed evaluation of JEM1498 AIP performance.

### D. LOCAL HYBRID TECHNIQUES

The local hybrid AIP solutions congregate the average advantages and drawbacks related to the passive and active approaches. In this sense, they can reduce the power quality degradation if compared to the active schemes and the NDZ if compare to the passive ones. The main shortfalls, in turn, are the increase in complexity and large detection time. Their principle of operation is divided in two stages. The first is the passive one, characterized by the pure monitoring of an electrical variable. If the AIP system suspects of an islanding occurrence, the active stage is triggered in order to confirm an islanding occurrence. Otherwise, the active stage is deactivated. This subsection will present the timeline evolution of the main hybrid AIP methods: SFS based hybrid AIP, SMS based, unbalance voltage, ROCOF and RPV approaches.

#### 1) SFS BASED HYBRID APPROACHES

In [19], is proposed a hybrid solution in which the SFS disturbance is triggered by the ROCOF monitoring. Once one of the main drawbacks of the hybrid solutions is the detection time, the use of ROCOF can improve this indicator, since its dynamics is faster than the frequency one. The results indicate that the scheme is able to detect islanding for loads with  $Q_f \leq 5$ . More than that, the strategy presented good performance in weak grid conditions and multi-DG environments, being able to distinguish islanding and non-islanding contingencies.

In [169], is proposed a hybrid method in which the SFS perturbation is activated by the reactive power monitoring. More than that, it uses the Adaptive Particle Swarm Optimization (APSO) in order to calculate the optimum value of the gain  $K$  to guarantee correct islanding detection with minimum THDi and to mitigate the stability impacts. Computational results indicate the possibility of detecting islanding for  $Q_f = 2.5$  and power mismatch load conditions. However, experimental efforts are still needed to confirm the algorithm capabilities.

#### 2) SMS BASED HYBRID APPROACHES

In [170], is proposed a new hybrid AIP in which the active stage inserts the same phase disturbance than the SMS algorithm. The passive stage, in turn, is triggered by the frequency estimation performed by a droop control. The proposed algorithm was tested under UL1741 Standard considerations in a computational simulation and achieved correct islanding detection for different values of quality factor for a single and a multi-DG system. In [171] is proposed

a similar approach able to perform islanding diagnosis in a multi-DG environment.

### 3) VOLTAGE UNBALANCE APPROACHES

As previously discussed, the islanding occurrence in a three-phase system can lead to voltage unbalance. Some authors use the voltage unbalance as the passive stage of different anti-islanding techniques. Reference [20] proposes an AIP solution that integrates the concept of voltage unbalance monitoring with frequency perturbation.

In [146], is proposed a hybrid strategy which the active stage is based on the perturbation of the inverter reactive power and is activated by the passive monitoring of three passive variations: voltage unbalance, ROCOF and voltage variation. The correlation between the inserted perturbation and the frequency variation is monitored and, if it trespasses a preset threshold, the occurrence of islanding is confirmed. The computational results indicate effectiveness for different load conditions and islanding detection capabilities in a multi-DG environment with no need of communication between the inverter units.

In [90] is proposed an AIP algorithm that combines passive voltage unbalance and total harmonic distortion (VU/THD) detection methods with the active bilateral reactive power variation (BRPV). It also provides a specific methodology for the correct choosing of the harmonic detection threshold, based on circuit analysis. The results show compliance with the [2] and [42] requirements and good performance in multi-DG environments.

### 4) ROCOF BASED APPROACHES

The ROCOF monitoring is a powerful tool to perform passive islanding detection and, therefore, can be successfully applied to perform the passive stage of hybrid AIP algorithms. In addition to the already mentioned [19] and [173], in which the ROCOF works in parallel with the SFS and SMS, respectively, [172] proposes a hybrid solution formed by passive ROCOF monitoring and active perturbation of the inverter output reactive power. Results indicate faster islanding detection than other approaches cited in [149] and [108].

In [173] is proposed a new ROCOF based hybrid AIP for the detection of islanding in a distributed generation (DG) system. The proposed method combines the features of the passive monitoring of ROCOF with perturbation proposed in [108]. The proposed solution was applied to a 9 MW wind power DG connected to a 1000 MVA, 25 kV grid, and the experiments were conducted using the MATLAB/Simulink environment. Although the simulation results indicate that the method detects the zero-power mismatch islanding within 200ms and unbalanced islanding within 100ms, experimental efforts are still needed in order to validate the strategy.

### 5) OTHER ROC BASED APPROACHES

As previously mentioned, the passive AIP systems rely on monitoring the derivative of a measured electrical quantity

rather than the quantity itself. In this context, it is also possible to use monitoring of the rate of change of an electrical variable in order to accomplish the passive stage of hybrid techniques.

In this context, [22] proposes a hybrid AIP solution that utilizes the ROCOV as the passive stage. When the measured ROCOV value exceeds a predetermined threshold, a real power shift (RPS) is initiated in order to deviate the voltage magnitude out of the allowed range of operation. The effectiveness of the algorithm in detecting islanding condition and preventing power generation system from supplying power to the isolated grid was tested through simulations of various events like induction motor starting, capacitor switching and wind turbine generator switching, demonstrating the system's ability to detect islanding conditions and prevent false positive diagnoses.

In this context, [115] proposes a hybrid method that utilizes the ROCOV as the passive stage and perturbation of the inverter output active power as the active one. The method was tested under various conditions, such as starting induction motors, energizing transformers, and operation with multiple DGs. The results indicate that the method is selective for non-islanding events and capable of detecting islanding for loads within the range of quality factors from  $0 < Q_f \leq 5$ . However, experimental efforts are still needed in order to validate the strategy.

## E. INTELLIGENT PASSIVE TECHNIQUES

As previously discussed, many methods used for detecting power system events suffer from the problem of choosing the appropriate threshold for detection. While frequency and voltage-based schemes have recommended thresholds provided by Standards, other methods such as ROCOF, ROCOV, HD, and HI implementation are marked by the difficulty of selecting the correct threshold for detection.

In this sense, [36] defines that the AIP research would probably shift toward the use of intelligent classifiers, such as Artificial Neural Network (ANN), fuzzy logic (FL), decision tree (DT), Artificial Neuro-Fuzzy Inference System (ANFIS), Static Vector Machine (SVM) since those classifiers eliminates the ‘‘Herculean task’’ of detection threshold definition. These methods derive features from the signal and use them as input to the intelligent classifier for decision making. This subsection, in this context, will cover the timeline evolution of each intelligent AIP approach. It is important to state that some active methods such as [133] and [169] use some kind of Machine Learning (ML) algorithm. However, they will not be included in this section, as the application of ML is limited to the dynamic parameterization of the methods and is not directly related to the islanding decision itself.

### 1) DECISION TREES

DTs are a type of machine learning algorithm that analyze data inputs and perform binary classification based on different features to make decisions. Decision trees can be trained

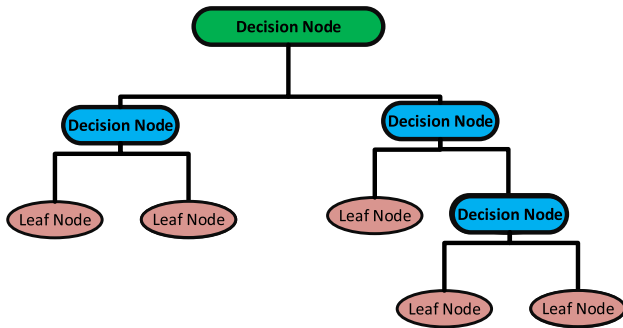

FIGURE 12. Generic DT algorithm representation.

on data that includes examples of both normal grid operation and islanding events, allowing them to learn to recognize the electrical signals associated with islanding. Once trained, the decision tree can be used to classify new data and trigger an automatic shut-off mechanism to disconnect the distributed generation source if an islanding event is detected, improving the safety and reliability of the electrical grid [174]. Figure 12 demonstrates the generic algorithm of a DT algorithm.

In [175] is proposed a DT based solution that uses Wavelet Transformation (WT) process the signals and extract features from transient deviations of PCC voltage and inverter output current for distinguishing non-islanding contingencies, avoiding the false tripping of the DGS. The obtained results achieved better accuracy when it comes to islanding detection than passive solutions such as the ROCOF relay and the OUV/OUF method. However, it is necessary to state that while OUV/OUF and the ROCOF algorithm reached a 100% rate of selectiveness, the DT solution reached 93.75% and the average detection time were around of 2 cycles of conduction. The solution proposed in [176] also uses the DT+WT combination to perform loss of mains detection. Computational results demonstrated a 98% efficiency and an average detection time of 1 cycle.

In [25] is proposed a solution based in the concept of Random Forest Classification (RFC). RFC combines multiple decision trees to improve performance. The solution uses a total of 21 features sampled at a 1kHz frequency. The results reached 100% of correct classification for islanding events for synchronous machine and inverter based-DGS. Alternately, it is possible to reduce computational burden using only four conditions. The total efficiency, however, is decreased to 98%.

In [177] is proposed an DT based AIP approach in which the selected features are in different measurement window, according to its specificities. This is an important advantage when it comes to detection time, since it allows the fast classification of casual islanding contingencies, in which is not verified a mismatch between energy production and consumption. The results indicate a (>99%) rate of accuracy and the detection time for 79% of the tested cases remained bellow of 20ms.

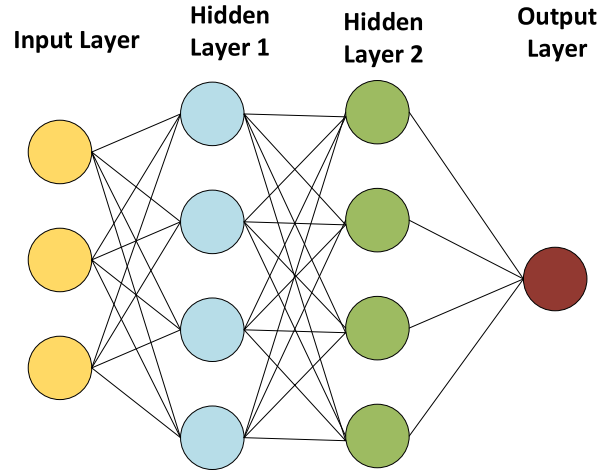

FIGURE 13. Generic ANN algorithm representation.

## 2) ARTIFICIAL-NEURAL-NETWORK

An Artificial Neural Network (ANN) is a machine learning algorithm formed of a large number of interconnected processing elements, called neurons, which are organized into layers. Each neuron receives input signals from other neurons and produces an output signal, which can then be used as input to other neurons in subsequent layers [178], according the representation of Figure 13. One important step in the training of ANNs is feature extraction, which involves identifying and selecting relevant features from the input data that are most useful for making predictions. The main strategies used to perform feature extraction are: phase space, DFT, Hilbert Transform (HT) Discrete Wavelet Transform (DWT) and Tunable Q-factor Wavelet Transform (TQWT) [38].

In [179], is proposed an ANN based AIP that applies the Variational Mode Decomposition (VDM) and the HT to perform feature extraction and the Grey Wolf Optimized ANN as the intelligent islanding classifier. The method was test under a multi-DG system environment formed by 2 synchronous machines and 2 PV systems. The results indicate efficacy in terms of islanding classification accuracy, computation time, and robustness against noise conditions.

In [29], is proposed an islanding detection methodology formed by two stages. In the first stage, discrete Fourier transform (DFT) is used to extract features from captured voltage and current waveforms, which are then used to calculate symmetrical components of the second-order harmonic for voltage, current, and voltage times current. In the second stage, a K-nearest neighbors (KNN) based classifier is used with nine features as input to classify islanding occurrence.

In [180] is proposed a new ANN based AIP that replaces the traditional approach for a single-hidden layer feedforward neural network called the Extreme Learning Machine (ELM). It randomly selects input weights and hidden layer biases and analytically calculates the output weights. The results of the proposed method were compared with the DT based AIP, achieving more accuracy for islanding and non-islanding

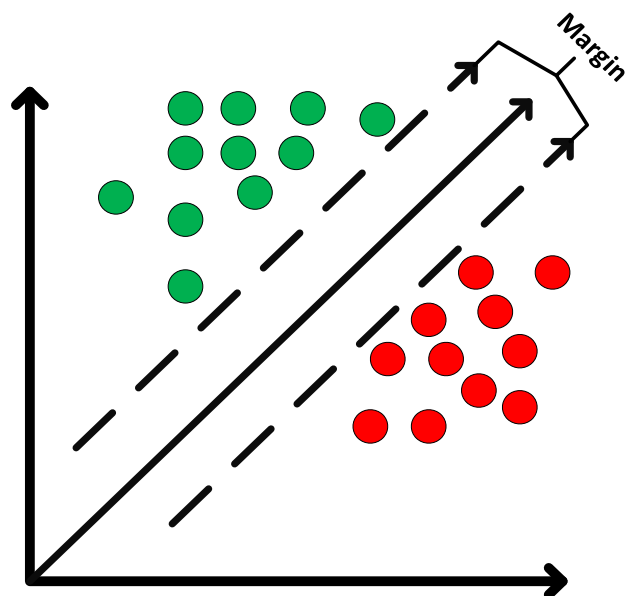

FIGURE 14. Generic SVM algorithm representation.

events. The ELM strategy is also applied in [181] reaching a total accuracy of 99.09%.

Some approaches use the Wavelet Transform (WT) in order to provide correct feature extraction. In [182] is proposed an AIP algorithm that uses both, WT and Mathematical Morphology (MM) in the extraction stage. The classification is performed by an ELM. The obtained result shows the effectiveness of the proposed IDM even under extremely noisy conditions, having an accuracy of 100% depending on the size of the training data set.

Paper [183] proposes an anti-islanding algorithm based on artificial neural networks (ANNs) that utilizes the Tunable Q-Factor Wavelet Transform (TQWT) for feature extraction. TQWT is a wavelet transform technique with tunable control parameters that can adjust the oscillating actions of a control signal. These tunable parameters include the decomposition stage number, redundancy, and Q-factor. The paper also introduces a methodology for parameterizing the algorithm. Computational results demonstrate an efficiency rate of 98% for both islanding and non-islanding events.

### 3) SUPPORT VECTOR MACHINE

Support Vector Machines (SVMs) are supervised learning algorithms used for classification and regression analysis. SVMs aim to find the hyperplane that maximally separates the data into different classes, with a margin between closest data points in each class, according to Figure 14. SVMs can handle both linear and non-linear data, making them widely applied in protection of electrical power systems, especially for event classification and islanding detection [184].

This approach provides an important advantage if compared to the previous ANN performance. Since its operation is based on the concept of Structural Risk Minimizing (SRM)

that focuses on minimizing an upper bound on the expected risk, rather than minimizing the error on the training data. Consequently, it is possible to achieve better accuracy with a smaller training dataset [27].

In the context of anti-islanding theory, it is possible to highlight some SVM based approaches. In [185], it is proposed an AIP scheme that performs the extraction of the following features: voltage, frequency, voltage phase angle, ROCOV and ROCOF. The technique successfully detects islanding events for an active power imbalance of 5% and above, whereas the VS relay fails for an imbalance of less than 8.8%.

In [186] is proposed an SVM-based event classification algorithm that can be used for islanding detection. The operating principle depends on the extraction of eight PCC features: frequency, active and reactive power, current, voltage, DHTv and DHTi. The AIP relay was tested under the UL741 considerations, accomplishing effectiveness, selectivity, accuracy and precision. The average detection time was 40ms and the method performance surpassed results achieved by ANN based algorithms.

### 4) FUZZY LOGIC

In contrast to traditional Boolean logic, which only allows for binary true/false decisions, Fuzzy Logic (FL) allows for partial truths, or degrees of truth. Fuzzy logic classifiers are useful in situations where the boundaries between classes are not well-defined, and when there is a high degree of uncertainty or imprecision in the input data. They are commonly used in applications such as pattern recognition, image processing, and control systems. In the context of electrical power systems, it is possible to apply fuzzy logic to perform islanding detection [187].

In [188], is proposed a FL based AIP that uses two stages to perform islanding detection. The first one is composed by a DT algorithm that receives eleven features (frequency, voltage, ROCOF, ROCOV, THDi, THDv, power factor, voltage deviation, ROCOP, ROCOFoP) and determines the three most significant ones to perform the loss of sources diagnosis. The second stage is composed of FL classifier that segregates the electrical events in two classes: islanding and non-islanding. The method was tested under three times of data set: ideal, a 20 dB signal rate to noise one, and a 30db signal rate to noise. For each data set, it was carried out 36 tests. The results indicate a 100% classification accuracy for ideal and 30db signal rate to noise, and a 94.52% for the 20 dB signal rate to noise one.

### 5) ADAPTIVE NEURO FUZZY INFERENCE SYSTEM (ANFIS)

ANFIS algorithms are a hybrid approach that combines the virtues of FL and ANN classifiers. It is a form of fuzzy inference system that uses a neural network to learn the membership function parameters for the fuzzy system, as illustrated by Figure 15. ANFIS can be used for a variety of tasks, including classification, regression, and control and,

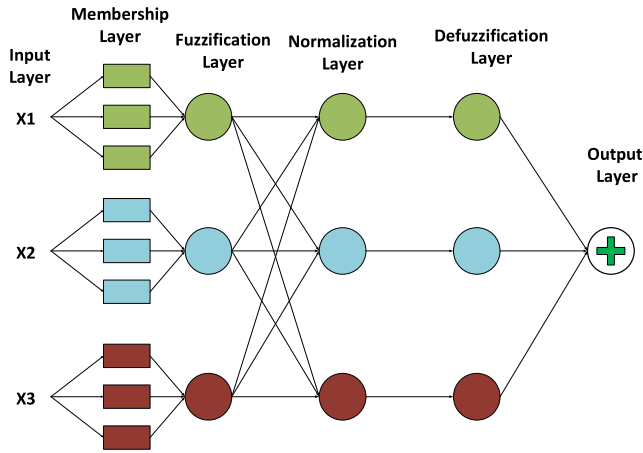

FIGURE 15. Generic ANFIS algorithm representation.

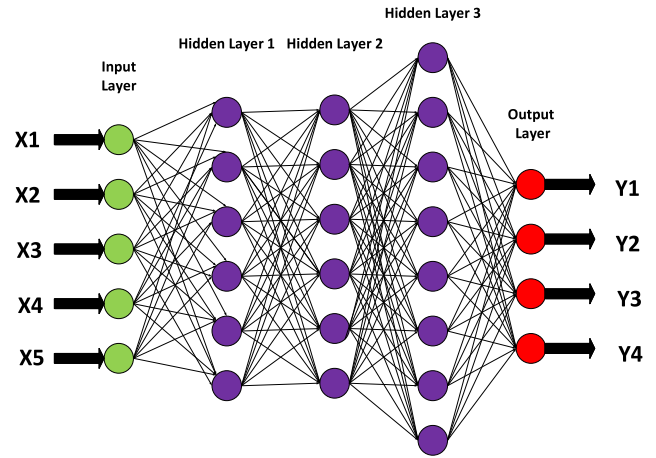

FIGURE 16. Generic DL algorithm representation.

therefore, can be applied to perform electrical fault classification and islanding detection [189].

In [190] is proposed a ANFIS AIP approach dedicated to wind turbines. The experimental validation demonstrates selectivity to non-islanding events and correct loss of sources diagnosis in 1.5s. Paper [191], on its hand, present a novel scheme that involves passive islanding detection through data clustering, where a simplified and robust fuzzy classifier is built using subtractive clustering. Results indicate better performance than the ROCOF relay.

In [28] is proposed a ANFIS approach that extracts seven inputs from the PCC: voltage, current, THDi, THDv, active and reactive power. The method was tested under the considerations of the UL741. Results indicate correct islanding detection with an accuracy of 78.4%. More than that, it presents a faster detection if compared to the other strategies presented in this section. Although the results indicate selectivity and efficiency, no experimental validation was given.

### 6) DEEP LEARNING (DL) BASED APPROACHES

Deep learning is a machine learning technique that uses multiple processing layers to learn representations of data with multiple levels of abstraction. The conventional ANN is based on back-propagation for training what can lead to the non-differentiation between local and global maximums, as illustrated by Figure 16. In order to solve the problem, was proposed the concept of DL which is based on a two-step procedure for training deep architectures using unsupervised pre-training followed by supervised fine-tuning [192].

In [193] is proposed the use of DL in the context of islanding detection. The proposed uses a stacked autoencoder based deep neural network and a regression algorithm to classify whether an islanding event is present or not. Results indicate an accuracy of 98.3% and detection time of 0.18 seconds. The method requires a relatively large sample size, with better performance than other classification methods.

Reference [95], proposes a DL approach composed by two stages. In the first one, voltage data sensed from the

PCC is subject to a Discrete Fourier Transform (DFT) in order to extract features uniquely related to islanding events and guarantee selectivity. Computational testing demonstrated the capability of detecting islanding in 6ms with an average accurate rate of 99.61%. The results also indicate a superior approach (in terms of accuracy and detection time) if compared to other strategies, such as: DT, SVM and ANN.

In [24], is propose a new DL based AIP composed by four phases: gathering three-phase voltage data, concatenating the data, transforming it into frequency spectrum time variations by short term Fourier transform, and feeding the phase and magnitude data into a deep neural network classification of islanding and non-islanding events. The results indicate an efficiency rate of 98.76%. More than that it was able to perform correct islanding diagnosis in a multi-DGS environment with no intrusion on power quality. Finally, it was also submitted to selectivity tests that proved the capability of distinguishing non-islanding contingences, such as load switching and short circuit faults.

### F. SIGNAL PROCESSING BASED TECHNIQUES

Passive islanding detection techniques can be improved by utilizing signal processing methods. These techniques offer versatility, stability, cost-effectiveness, and easy modification, which assist researchers in identifying hidden characteristics in measured signals for islanding detection. Based on these features, decisions can be made regarding whether islanding has occurred. Several signal processing tools such as Fourier transform, Stockwell-transform, Hilbert Huang transform, Wavelet Transform, and TT-transform are used for islanding detection, and their descriptions are discussed in the subsequent sections [39]. It is important to highlight that, as previously mentioned, some of the intelligent algorithms utilizes signal processing technologies to perform feature extraction. Those methods will not be included in this subsection.

### 1) WAVELET TRANSFORM (WT)

Wavelet transform is a mathematical technique used in signal processing to analyze signals and extract information from them. It decomposes a signal into a set of wavelets, which are small waves that are scaled and translated in time. The decomposition results in a time-frequency representation of the signal, allowing for the identification of localized features in both time and frequency domains. The wavelet transform can be applied to signals of any size and can capture both short-term and long-term changes in the signal [194]. As WT is a powerful signal processing technique it can be employed in image processing, audio analysis and data extraction. Regarding the electrical power system, it has been reported the use of WT to perform islanding detection and fault classification.

In [195] is found the first application of WT to perform islanding detection. The proposed method senses the PCC voltage and the inverter output current and applies the WT in order to extract high frequency harmonic components. The computational and experimental results indicate capability of detecting the loss of sources in less than 400ms for the condition in which the contributions levels of active and reactive power flowing from the grid are equal to zero.

In [196] is proposed a new WT based AIP in which incorporates the advantages of the wavelet transform, Singular Value Decomposition (SVD), and Shannon entropy to analyze the transient changes of the PCC parameters. By applying WT to the three-phase voltage signals, detailed coefficients are obtained. These coefficients are used to generate a singular value matrix and calculate the wavelet singular entropy (WSE) for each phase. Finally, it is determined the WSE index, formed by the sum of the WSE of each phase. The performance of the proposed solution was compared to conventional ROCOF and ROCOV relays and presented more selectivity and faster islanding detection.

In [197] is proposed an AIP that utilizes the concept of Wavelet Packet Transform (WPT) to extract signatures from the three-phase apparent power. The WPT is a linear combination of wavelets that is able of better represent transient oscillation of high frequency harmonic components [198]. The AIP methodology was tested in a hybrid DGS environment with a wind turbine emulator, a grid side converter and a permanent magnet generator. The experimental results indicate an average detection time of 10ms, low voltage ride through capabilities and no impact over the PCC power quality. Paper [199], in turn, uses a similar AIP approach applied to a cogeneration plant and reference [200] applies a similar technique in farm collector systems.

In [201] is proposed an AIP approach that modifies the classic continuous WT in order of achieving the application of real-time implementation and utilizing non-stationary signal analysis to implement a hybrid islanding detection approach based on wavelets. Islanding patterns are detected by examining a dataset that includes power quality indicators such as voltage amplitude, duration of events, degree of imbalance, system frequency, grid impedance, and power angle. It was

tested in a microgrid environment composed by wind power plant, a battery bank, a PV system and synchronous generator. The results indicate capabilities of differentiating islanding events of other electrical contingences such as: phase to line short circuits and two-phase fault.

In [30] is also proposed a novel AIP method based on the adaptation of the discrete WT. It replaces the conventional discrete WT by a Second-Generation Wavelet Transform (SGWT) and a Maximum Overlap Discrete Wavelet Transform (MODWT). The first one is responsible for reducing the number of unnecessary computations, reducing memory demand and computational burden. The second one is responsible for the avoiding the decrease of the samples on each level of decomposition, preserving the signal length.

### 2) MATHEMATICAL MORPHOLOGY

Mathematical Morphology (MM) is a time-domain analysis that focuses on the set theory, integral geometry, and shape of a signal. Morphological filters based on MM use simple signal transformation tools such as addition and subtraction, which result in fewer computations compared to other signal processing techniques such as WT, ST, HST, and TTT. Due to its simplicity of implementation in can be applied to detect the loss of sources of DGS and fault classification as well [32].

In [202], is proposed a MM method of islanding detection that utilizes the MM operator dilation and erosion to create a Dilation-Erosion Differential (DED) filter responsible for extracting islanding patterns from the DGS output current and from the PCC voltage. The output of the DED filter is used to calculate the Mathematical Morphology Ratio Index (MMRI) that is, in turn, compared to a preset threshold in order to detect islanding. Computational results indicate an average detection time of 20ms. A similar approach is proposed in [203] that creates a MM based AIP dedicated to microgrids. Although it uses the same concept of DED filter, it uses only the PCC voltage to detect islanding. The proposed algorithm is adaptive and adjusts the threshold value for different power system conditions. Computational results indicate the possibility of detecting islanding in an average detection time of 10ms.

### 3) STOCKWEL TRANSFORM (ST)

The Stockwel Transform (ST) is suggested as a solution to address the shortcomings WT, which includes processing data in batches and sensitivity to noise. ST is a combination of the short-time Fourier transform and WT, which uses a scalable Gaussian variable window. ST changes a time series signal into a time-frequency representation and offers frequency-dependent resolution. It allows for multi-resolution without disrupting the phase of each frequency component. By using the amplitude or phase time-frequency spectrum, ST can observe local spectral characteristics and assist in detecting any disturbances, including islanding or other electrical faults [204].

In [31] is proposed a based AIP that applies the ST to process the inverter output current and create a median-based islanding recognition factor (MIRF). The current rate of change of the MIRF is then calculated by differentiating the root mean square current over time to get the current-based islanding recognition factor (IRFC). Simple decision rules are used to compare the peak magnitude of IRFC with pre-set threshold values to differentiate islanding events from faulty and operational events. It establishes two thresholds, the first one for fault detection and other for islanding contingences. Results attest selectivity for non-islanding events and correct loss of mains diagnosis for a 10dB rate of signal to noise.

In [23], is proposed a combination of the ST with the Hilbert transform extract voltage and current negative sequence data and calculate a current islanding detection indicator. It was tested under an IEEE-13 nodes model and the AIP approach effectively recognizes islanding events even in a noisy environment with a total 20dB rate of signal to noise, with an efficiency greater than 98%. It was also conducted a comparative study and the proposed strategy performance outstand conventional passive solutions, WT based algorithms and ANN based AIP methods.

In [205] is proposed an algorithm that uses ST-based multiresolution analysis to process voltage signals and obtain the variation index and the standard deviation to classify events between islanding and non-islanding. The algorithm performs well under noisy conditions and is efficient in detecting the grid interruption and segregate it from non-islanding contingences. The study was performed using MATLAB/Simulink software and validated in real-time using a real time digital simulator. The results indicate right discrimination between natural transient changes of electrical amounts from islanding.

#### 4) EMPIRICAL MODE COMPOSITION (EMC)

The Empirical Mode Composition (EMC) is a data-adaptive multiresolution signal processing technique that can be applied to non-stationary or non-linear signals in order to separate them in different groups of Intrinsic Mode Functions (IMFs) in different resolutions. EMC has been applied to islanding detection in [35]. The paper proposes a new AIP based on a Time Varying Filter Empirical Mode Composition (TVFEMC) that create two IMFs through the use of an adaptive cutoff frequency filter. The energy density of the IMF is calculated by a Teager energy operator and the results are compared to a preset threshold in order to perform islanding detection. Results indicate the capability of perform islanding under a 40dB signal to noise rate and selectivity regarding non-islanding events.

#### 5) HILBERT-HUANG TRANSFORM (HHT)

The Hilbert-Huang Transform (HHT) is a signal processing technique used to analyze non-linear and non-stationary time series data. It is composed by two stages: Empirical

Mode Decomposition (EMD) and Hilbert Spectral Analysis (HSA). EMD separates a signal into a group IMFs, which identify various frequency components of the signal. HSA, in turn, uses the Hilbert Transform to examine the instantaneous frequencies and amplitudes of these IMFs. Since HHT is a powerful tool for analyzing non-stationary signals, as it can capture changes in frequency content and amplitude over time and, therefore, can be used for islanding detection [204].

In [206] is proposed a HHT based AIP scheme. It senses the PCC voltage and the inverter output current and processes those signals through EMD to extract IMFs. The Hilbert Transform is computed for the voltage and current signals, and a ratio index is computed using these transforms. This ratio index is used to set a threshold to identify islanding events and distinguish them from non-islanding switching events. The proposed approach was able to detect islanding for a 5% of reactive power mismatch.

#### 6) VARIATIONAL MODE DECOMPOSITION (VMD)

The Variational Mode Decomposition (VMD) is a signal processing technique that decomposes the input signal  $u(t)$  in different discrete signals  $u_k(t)$ , which are sub-signals or band limited IMFs. It provides a more stable and accurate decomposition of signals compared to other techniques, allowing for the identification and separation of signal components with varying frequency content and amplitude modulations. VMD has been successfully applied in various fields and has the potential to provide new insights into scientific and engineering problems. In the context of DGS and microgrids, it is possible to apply VMD algorithms to perform islanding detection or fault classification.

In [207] it is proposed a novel AIP algorithm that utilizes the VMD concept to extract five IMFs from the PCC voltage. Posteriorly a control system calculates statistical features of standard variation and kurtosis index. The islanding diagnosis is based on the comparison between the obtained features with preset thresholds. Computational results are given for several islanding and non-islanding contingences. The method was capable of detecting the loss of mains even for a zero-power mismatch. In [208] it is proposed a similar VMD based approach. It disintegrates the PCC voltage in four IMFs and calculates energy index of the models according to a specific equation empirically obtained. The results indicate islanding capabilities for load with  $Q_f = 3.5$  even in a 20dB signal to noise rate.

In [34], is proposed approach utilizes VMD and Subspace-K-Nearest Neighbor (SSKNN) method to detect islanding events. The proposed method extracts 3-phase voltage signals, applies VMD to obtain principal modes, and formulates four feature indices based on the first three modes. The extraction features are processed in order to calculate the relative mode energy ratio index which is the basis for the islanding diagnosis. Results show that the proposed method is effective and meets the requirements of IEEE 1547 islanding detection standard.

### 7) KALMAN FILTER

The Kalman Filter (KF) is a mathematical algorithm that makes estimations based on a set of observed measures, including noise, over a period of time. It considers a joint probability distribution across the variables for each time frame and is used to generate accurate estimates of a system's state [209]. Due to its reliable signal estimation, even under well distorted data, it can be used for frequency measurements, harmonic decomposition, power quality monitoring, power conditioners control and synchronization, or to perform islanding detection [210].

In the context of islanding detection, KF has applied to perform the loss of sources classification in [33]. It proposes a new AIP approach in which the extend version of KF is applied to carry out frequency estimation in a microgrid environment and the islanding decision is based on the comparison of the frequency variance with a preset threshold. Computational results indicate that the frequency estimation performed by the extend KF suppers other strategies such as the conventional KF and the Fourier filter. More than that, islanding results indicate the method is able to carry out accurate islanding diagnosis even in a power balance condition. No selectivity result was given.

### 8) OTHER SIGNAL PROCESSING BASED AIP METHODS

Other known signal processing technologies applied to islanding detection are: Phaselet Transform (PT) and Time Time Transform (TTT). PT is defined as the application of sinusoidal or cosinusoidal function over the sum of the squares of the sensed data sample. It utilizes an adaptive measuring window that can adjust its length in order to improve feature extraction from the input signal. PT has been described as an effective method for islanding detection in [211] and [212]. TTT, on its hand, is defined as a signal processing method based on ST that is capable of constructing a double dimensional representation of a unidimensional signal. It has been applied to islanding detection in [213].

## V. CONCLUSION

The main anti-islanding strategies were discussed and segregated based on their principles of functioning. Finally, one can compile the advantages and drawbacks of each approach, highlighting the main cited works that addressed the problems related to each AIP algorithm.

The remote methods consist of the AIP systems located out of the converter either in the grid side or in the DGS side. Generally speaking, this approach has advantages related to the avoidance of negative effects on power quality and NDZ, as well as effectiveness in multi-DG islanding; its drawbacks, on the other hand, rely on high-cost implementation, elevated complexity, and mandatory maintenance. The first cited approach was the periodical switching of a capacitor bank in the DGS bus. In spite of its popularity in the past, especially during the 1990s, it was abandoned due to several problems related to response time and low efficiency. In this scenario

emerged the DTT solutions and the PLCC based methods in which the monitored data is sent to a control main that performs the loss of sources diagnosis. The use of PLCC can reduce price since it uses the main power line, while the DTT demand a proper communication infrastructure. However, PLCC is not recommended to high lines as it requires the installation of repeaters every 15km of line.

The application of PMU and MPMU was also addressed by several papers, as it has been successful classified islanding and non-islanding events in real power plants and in uncontrolled environments. PMU and MPMU can provide accurate and precise data with fewer errors compared to conventional measurements. They are capable of detecting islanding during power transmission over long ranges and can handle large-scale systems. However, they include communication delays and the possibility of missing data points due to technical issues with the PMU's multiple components [214]. The key performance factors of PMU approaches are the resolution and the reliability of the sensed data. In this sense, the performance of MPMU can be considered superior since it works on lower voltage levels. Another problem related to the application of PMU on islanding detection context is the possibility of cyberattacking, since several PMU devices has internet connection. This problem can be solved by the use of specific communication channel for islanding detections, as studied in [82].

The second set of AIP methodologies was the passive techniques. Defined by the monitoring of the PCC variables, the islanding diagnosis is performed by the comparison of the obtained data with preset thresholds. The first passive strategy addressed was the OUF/OUV method, that analyzes frequency and voltage instantaneous values. Despite its simplicity, this solution suffers with low efficiency for power balance conditions and, therefore, is not able to reach the minimum AIP Standards recommendation. Similar considerations can be generalized for the PJD scheme.

The HD approach, in turn, monitors the harmonic content of the PCC voltage in order to diagnosis the utility grid state. This is one of the passive AIP technologies able to perform islanding detection capable of detecting grid interruption in a power balance condition. However, it is important to highlight that this approach has several disadvantages when it comes to selectivity and multi-DG performance. In relation to the selectivity, the method can understand natural contingencies, such as nonlinear load switching, as a loss of mains. In order to correct this problem, some papers propose a specific interlocking between THD and other electrical quantity such as ROCOF or the voltage unbalance [88]. The multi-DG performance problem, in turn, can be solved by the monitoring of the high frequency harmonic components, generated by the inverter PWM.

Some passive methods utilize the derivative of an electrical variable in order to detect islanding due to transient variations provoked by the grid interruption. The ROCOF appears as the outstanding method of this approach. It has an advantage in relation to NDZ [109] and to detection time [101] compared

to other passive technologies. However, it presents problems related to implementation complexity and nuisance trips. The implementation difficulty relies on the choosing of correct measuring window. This is well solved by [96] and [100]. In relation to the nuisance trip, references [101] and [102] proposes interlocking of the ROCOF relay with the THDi and with the estimated grid impedance, respectively. The other solutions based on rate of change determination has the same advantages and drawbacks. However, they lack a deeper literature in order to address correctional strategies to improve their performances.

Following the evolution timeline, the active solutions improve the accuracy of the passive techniques by inserting small disturbances in some electrical variable. These methods can perturb the frequency, voltage, or harmonic component of the inverter output. The active AIPs that disturb the frequency are the AFD based methods, the SMS and the RPV. All of them create a phase difference between the DGs output current and the PCC voltage, being well recommended for unitary power factor inverters. Some of these approaches present problems related to high harmonic content and malfunctioning in the multi-DG environment such as the Classic AFD and the IAFD. Other methods present high detection time: RPV and the AFDPCF. In relation to the multi-DG performance, the methods that incorporate positive feedback such as SFS, SMS and APJPF are the ones that best perform due to the capability of following the frequency drift imposed by the loads. It is also necessary to highlight that positive feedback improves islanding performance by eliminating NDZ for a given interval of  $Q_f$  values. However, the gain of the positive feedback can degrade inverter stability. One form of overcoming this issue is through the bilateral variation of ancillaries parameters, as exposed in [132] or by the adoption of adaptive gains with [133], [169], [170], [171], [172], [173] or without machine learning techniques.

The active methods that disturb voltage are the SVS based techniques. The primary benefit is the capability to identify islanding even when the power supplied by the distributed generation source does not match the power demanded by the load. Additionally, it can be inferred that this method is less affected by the reactive load parameters because the voltage is less influenced by the reactive power flow of the grid. Nonetheless, SVS scheme performs slow islanding detection [139] and can also impact the inverter stability, due to the positive feedback of current. This problem can be mitigated by using an adaptive gain as in [140].

The last group of active techniques is based on harmonic insertion. It is similar to harmonic detection with the difference of actively generates proper harmonic components in the inverter output current. The most chosen component is the second one [17], [18], [19], [20], [21], [22], [23], [24], [25], [26], [27], [28], [29], [30], [31], [32], [33], [34], [35], [36], [37], [38], [39], [40], [41], [42], [43], [44], [45], [46], [47], [48], [49], [50], [51], [52], [53], [54], [55], [56], [57], [58], [59], [60], [61], [62], [63], [64], [65], [66], [67], [68], [69], [70], [71], [72], [73], [74], [75], [76], [77], [78], [79],

[80], [81], [82], [83], [84], [85], [86], [87], [88], [89], [90], [91], [92], [93], [94], [95], but some works addresses the fifth or the ninth. The complex task of extracting the voltage harmonic component can be realized by DFT, Goertzel Algorithm [60] or by cross correlational schemes [159], being the last one the most economical in terms of computational burden. Some problems faced by harmonic insertion-based methods relay on the possibility of disturbance filtering by high capacitive loads, what can be solved by the inserting subharmonic components [154]. Other related problem is the malfunctioning in the multi-DG environment, due to the non-synchronization between the distortion inserted by each inverter. In this sense, [59] establishes the calculation of the upgrade factor in order to determine if a given AIP based on harmonic insertion can be incorporate for a given DGS without compromising the islanding detection capabilities. Paper [156], on its hand, concludes that the compatibility of Harmonic Injection schemes in a multi-DG environment depends on a phase difference in the interval of  $[-\pi/2; \pi/2]$ .

Hybrid techniques are composed by two stages: monitoring and disturbance injection. In general, the cited works utilizes the aforementioned passive techniques to perform the monitoring and the already known active methods to conduct the disturbance injection. Thus, they present the average benefits and weaknesses of passive and active solutions. The great disadvantage is the detection time in the order of 200ms. The strategy proposed by [115], however, achieved corrected islanding positive diagnosis in 14ms. Although it a very fast detection, it is important to highlight the fact that the method was not tested under with a perfect power mismatch.

In relation to the machine learning algorithms is important to highlight the capability of performing fast islanding detection in multi-DG environments and the selectivity for non-islanding events. Almost all the cited machine learning based AIP references present results of non-islanding events such as motor starting, capacitor bank switching and line to ground faults. However, the performance of those solutions is dependent on the number of extracted features and on the quality and size of the data training set. The references [95], [177], [181], and [182] obtained an efficiency superior to 99%. However, they depend on the extraction of 16, 9 and 6 features, respectively. One of the most important gaps of the machine learning based AIP literature is the lack of experimental results, what is justified for the complexity of the systems in which they are employed.

Finally, the last group of techniques is the signal processing-based methods. In general, those technologies can be applied to perform passive AIP, extracting relevant information from the sensed data. In this sense, they can improve performance of machine learning algorithms, as in [179], [182], and [183] or be applied without any intelligent classifier [198], [199], [200], [201], [202], [203], [204], [205], [206], [207], [208], [209], [210], [211], [212], [213], [214]. The results of the cited literature indicate good selectivity capabilities and fast islanding detection.

**TABLE 3. Synthesis of the main performance indicators of the analyzed AIP methods.**

Group	Method	Reference	NDZ	Detection Time	Power Quality Impact	Multi-DG	Selectivity	Microgrid Application	
Remote	Impedance Insertion	[6]	High	1.5s	High	-	-	-	
	DTT	[66]	Small	500ms	None	Good (2)	-	-	
	PLCC	[68]	Small	200ms	None	Good (2)	-	-	
	SCADA	[71]	Small	-	-	-	-	-	
	PMU	[74]			0.2-498s	None	-	LS	-
		[77]	Small	500ms	None	Good (3)	-	-	
	MPMU	[78]	Small	275ms	None	Good (3)	LS	-	
		[9]	Small	31-457ms	None	-	LS and load shedding	-	
		[81]	Small	14ms	None	Good (2)	LS, MS and 3F	-	
		[82]	Large	10ms	None	-	1F, 3F	Yes	
	[10]	Small	250ms	None	Good (2)	LS, 3F, MS	-		
Passive	OUV/OUF		High	4ms -2s	None	-	-	-	
	PJD		High	-	None	-	-	-	
	HD	[88]	High	53-129ms	None	Good (3)	MS, CB	-	
		[89]	High	500ms	None	Good (3)	MS, CB, 1F, 3F	-	
	ROCOF	[92]	Small	45 - 697ms	None	-	NLL	-	
		[93]	Small	75 - 445ms	None	Good (2)	-	-	
		[97]	Medium	250ms	None	Good (2)	-	-	
		[101]	Medium	30ms	None	-	NNL	-	
		[102]	Small	-	None	-	LS	-	
		[103]	Small	-	None	-	-	-	
	[104]	Medium	-	None	-	-	-		
	[105]	Small		None	Good (5)	CS, MS, 1F, 3F	Yes		
	ROCOV	[114]	Small	510ms	None	Good (2)	CS, MS, 1F, 3F	Yes	
	ROCPAD	[119]	Small	100ms	None	Good (2)	3F, MS	-	
	ROCOP	[120]	Large	200ms	None	-	-	-	
	ROCORP	[121]	Medium	-	None	-	-	-	
	ROCOFOP	[122]	Large	300ms	None	-	CB, MS	-	
	ROCOAP / ROCORP	[123]	Medium	10ms	None		CB, MS	-	
Active	AFD	[124]	Large	269ms	High	Poor	-	-	
	IADF	[125]	Large	200ms	Medium	Poor	-	-	
	AFD by Chen	[126]	Large	150ms	Low	-	-	-	
	AFDPCF	[127]	Small	400ms	Low	Poor	-	-	
	SFS	[124]	Small	167ms	Low	-	-	-	
		[130]	Small	-	Low	Good (2)	-	-	
	[133]	Small	-	Low	Good (2)	CB, MS, LS	-		
	[132]	Small		Low	Good (2)	-	-		
	[134]	Small	-	High	-	-	-		
	SMS	[136]	Small	75 - 115ms	Small	-	LS	-	
	APS	[135]	Small	200ms	Small	-	-	-	
	IAPS	[136]	Small	100ms	Small	-	-	-	

**TABLE 3. (Continued.) Synthesis of the main performance indicators of the analyzed AIP methods.**

	<b>SVS</b>	[139]	Small	312ms	Small	-	-	-
	<b>MSVS</b>	[140]	Small	10ms	Smaller than SVS	-	-	-
	<b>RPV</b>	[142]	Medium	200ms-1s	Medium	Bad (2)	-	-
		[145]	Medium	140ms-480ms	Medium	Good (2)	LS	-
		[144]	Medium	120ms-1.51s	Small	-	-	-
		[148]	Medium	30 - 50ms	Small	-	-	-
		[149]	Small	50-103ms	Small	-	-	-
		[145]	Small	85ms	Small	-	LS	Yes
		[150]	Small	60-360ms	Medium	Good (2)	-	-
		[147]	Small	90-109ms	Small	Good (3)	LS	Yes
	<b>HI</b>	[17]	Small	275ms	Medium	-	-	-
		[60]	Small	<120ms	Small	-	-	Yes
		[152]	-	40ms	Medium	-	-	-
		[153]	-	200ms	Small	-	-	-
		[154]	-	320-480ms	Small	-	-	-
		[155]	-	<170ms	Small	Good (4)	-	Yes
		[159]	Small	<400ms	Small	-	NNL	-
	<b>Negative sequence</b>	[160]	-	60ms	Medium	Good (2)	Low performance	-
		[162]	-	125ms	High	Good (2)	-	-
	<b>Modern feedback techniques</b>	[163]	Small	<500ms	Small	-	-	-
		[46]	Small	<100ms	Small	-	-	-
		[166]	Small	<100ms	Small	-	-	-
		[167]	Small	<217ms	Small	-	-	-
	<b>JEM AIP</b>	[168]	-	<200ms	Medium	Good (4)	-	-
<b>Hybrid</b>	<b>SFS based approach</b>	[19]	Medium	-	Small	Good (2)	CB, MS, load changing	-
		[169]	Medium	-	Medium	-	-	-
	<b>SMS based Approach</b>	[170]	Medium	-	Small	-	LS	-
		[171]	Small	189ms	Small	Good (4)	CB, MS, load changing	-
	<b>Voltage Unbalance</b>	[20]	-	150ms	Medium	Good (2)	-	-
		[146]	Small	173ms	Small	Good (3)	-	Yes
		[90]	Small (QF<2.5)	138ms	Small	Good (2)	load changing, nonlinear LS	-
	<b>ROCOF</b>	[172]	Medium	266ms	Medium	-	-	-
		[173]	-	200ms	Medium	-	CB, LS	-
	<b>Other ROC</b>	[22]	Medium	-	Medium	-	CB, MS, load changing	-
		[115]	Medium	14ms	Small	Good (2)	MS, inrush current transform	Yes
<b>Machine Learning</b>	<b>DT</b>	[175]	Small	30ms	None	Good (2)	LS, CB, MS, 3F	-
		[176]	Small	50ms	None	Good (2)	LS, CB, MS, 3F	-
		[25]	Small	115-370ms	None	Good (2)	CB	-
		[177]	Medium	20ms	None	-	LS, CB, MS, 3F	-
	<b>ANN</b>	[29]	Small	15ms	None	-	LS	Yes

**TABLE 3. (Continued.) Synthesis of the main performance indicators of the analyzed AIP methods.**

		[179]	Medium	42ms	None	Good (4)	LS, CB, 3F	Yes
		[180]	Small	-	None	Good (4)	98% efficiency	Yes
		[181]	Small	-	None	Good (2)	LS, CB, MS, 3F	Yes
		[182]	Small	-	None	Good (2)	LS, CB, MS, 3F	Yes
		[183]	Small	-	None	-	LS, CB, MS, 3F	-
	<b>SVM</b>	[185]	Medium	200ms	None	Good (3)	LS, CB, MS, 3F	-
		[186]	Small	40ms	None	Good (2)	LS, CB, MS, 3F	Yes
		[27]	Medium	-	None	-	LS, CB, MS, 3F	-
	<b>FL</b>	[188]	-	-	None	Good (2)	DG tripping, 3F	-
	<b>ANFIS</b>	[190]	Medium	500ms	None	-	CB, MS	-
		[191]	Large	50ms	None	-	MS, LS, CB	-
		[28]	Small	15-45ms	None	Good (2)	1F, LS, CB	Yes
	<b>DL</b>	[193]	Small	180ms	None	-	Voltage sag and swell	Yes
		[95]	Small	10ms	None	Good (2)	LS, CB	Yes
		[24]	Small		None	Good (4)	LS, CB, 1F, 3F	-
<b>Signal Processing</b>	<b>WT</b>	[30]	Small	300ms	None	-	CB, MS, load changing	-
		[195]	Small	30ms	None	-	-	-
		[196]	Medium	40ms	None	Good (7)	-	Yes
		[197]	Small	10ms	None	-	LS, 1F, 3F	Yes
		[199]	Small	-	None	-	LS, 1F, 3F	-
		[200]	Small	6ms	None	Good (4)	LS, 1F, 3F	-
		[201]	Small	-	None	Good (4)	1F, 3F	Yes
	<b>MM</b>	[202]	Small	20ms	None	Good (3)	MS, CB, 1F, 3F	Yes
		[203]	Medium	-	None	Good (2)	MS, CB, 1F, 3F	Yes
	<b>ST</b>	[205]	Small	40ms	None	Good (2)	MS, CB, 1F, 3F	-
	<b>HT</b>	[206]	Medium (5%)	14ms	None	-	-	-
	<b>VMD</b>	[207]	Small	30ms	None	-	MS, CB, 1F, 3F	-
		[208]	Small	10ms	None	-	-	-
	<b>PT</b>	[211]	Small	20ms	None	-	MS, CB, 1F, 3F	-
	<b>TTT</b>	[213]	Medium	700s	None	Good (2)	3F	-

In the view of the foregoing, Table 3 summarizes the main performance indicators of the analyzed AIP methods regarding the results of NDZ, detection time, power quality degradation, multi-DG performance and selectivity. The multi-DG column will classify the performance of the method in “Good” or “Poor”. The methods classified as “Good” will present the respective number of DGs they were tested in the respective reference.

In this sense, a method classified as “Good (3)”, for instance, presented a satisfactory performance for a system with three distributed systems connected to the PCC. AIP schemes that were not tested in a multi-DG environment will present a “-”. In relation to the selectivity, the table will present a similar indicator of and will present the

non-islanding events used in each reference to testify selectivity. The main events are: Motor Starting (MS), Capacitor Bank (CB) switching, Load Change (LC), single phase fault (1F), three-phase fault (3F) and others. Finally, the last column will map the AIP methods that were tested in microgrid environments in order to understand lack of the emerging topic of AIP of microgrids.

From this perspective, Table 3 intends to map the future work of anti-islanding literature. Indeed, the reality is that the latest anti-islanding research papers should not solely focus on devising novel protection techniques. They must also delve into addressing the challenge of multiple inverters, each embedded with distinct Anti-Islanding Protection (AIP) strategies. Furthermore, comprehensive selectivity analyses need to be carried out meticulously to guarantee the preven-

tion of unwarranted tripping. Lastly, a crucial step involves subjecting anti-islanding algorithms to testing within microgrid setups, facilitating the seamless transfer of control following an inadvertent islanding event. Summarizing, the future work should focus on:

- Proposal of new AIP strategies capable of detecting loss of sources for high quality load factors ( $Q_f > 2.5$ );
- Multi-DG studies in which is analyzed the interaction of new AIP methods with the already existing schemes;
- Selectivity studies to insure the methods are able to distinguish between islanding and non-islanding events, especially for active and hybrid strategies;
- Microgrid application to ensure the seamless control transference even after an unintentional islanding in a generation-consumption equilibrium condition.

## ACKNOWLEDGMENT

The authors thank to professors Luiz C. Freitas (CNPq 304479/2017-9), João B. V. Júnior (CNPq 304489/2017-4), Gustavo B. Lima, and Ernane A. A. Coelho (FAPEMIG APQ-03554-16), for supporting this project.

## REFERENCES

- [1] M. H. Saeed, W. Fangzong, B. A. Kalwar, and S. Iqbal, "A review on microgrids' challenges & perspectives," *IEEE Access*, vol. 9, pp. 166502–166517, 2021, doi: [10.1109/ACCESS.2021.3135083](https://doi.org/10.1109/ACCESS.2021.3135083).
- [2] *IEEE Recommended Practice for Utility Interface of Photovoltaic (PV) Systems*, IEEE Standard 929-2000, p. i-, 2000, doi: [10.1109/IEEEESTD.2000.91304](https://doi.org/10.1109/IEEEESTD.2000.91304).
- [3] M.-S. Kim, R. Haider, G.-J. Cho, C.-H. Kim, C.-Y. Won, and J.-S. Chai, "Comprehensive review of islanding detection methods for distributed generation systems," *Energies*, vol. 12, no. 5, p. 837, Mar. 2019, doi: [10.3390/en12050837](https://doi.org/10.3390/en12050837).
- [4] D. Narang, S. Gonzalez, and M. Ingram, "A primer on the unintentional islanding protection requirement in IEEE Std 1547–2018," *Nat. Renew. Energy Lab., Golden, CO, USA, Tech. Rep. NREL/TP-5D00-77782*, pp. 1–34, 2022. [Online]. Available: <https://www.nrel.gov/docs/fy22osti/77782.pdf>
- [5] A. Etxegarai, P. Eguía, and I. Zamora, "Analysis of remote islanding detection methods for distributed resources," *Renew. Energy Power Quality J.*, vol. 1, no. 9, pp. 1142–1147, May 2011, doi: [10.24084/repq09.580](https://doi.org/10.24084/repq09.580).
- [6] A. Kitamura, M. Okamoto, K. Hotta, K. Takigawa, H. Kobayashi, and Y. Ariga, "Islanding prevention measures: Demonstration testing at Rokko test center for advanced energy systems," in *Proc. Conf. Rec. 23rd IEEE Photovoltaic Spec. Conf.*, Feb. 1993, pp. 1063–1067, doi: [10.1109/PVSC.1993.346977](https://doi.org/10.1109/PVSC.1993.346977).
- [7] M. E. Ropp, K. Aaker, J. Haigh, and N. Sabbah, "Using power line carrier communications to prevent islanding," in *Proc. Conf. Rec. IEEE Photovolt. Spec. Conf.*, Jan. 2000, pp. 1675–1678, doi: [10.1109/PVSC.2000.916224](https://doi.org/10.1109/PVSC.2000.916224).
- [8] R. A. Walling, "Application of direct transfer trip for prevention of DG islanding," in *Proc. IEEE Power Energy Soc. Gen. Meeting*, May 2011, pp. 26–28, doi: [10.1109/PES.2011.6039727](https://doi.org/10.1109/PES.2011.6039727).
- [9] Y. Guo, K. Li, D. M. Laverty, and Y. Xue, "Synchrophasor-based islanding detection for distributed generation systems using systematic principal component analysis approaches," *IEEE Trans. Power Del.*, vol. 30, no. 6, pp. 2544–2552, Dec. 2015, doi: [10.1109/TPWRD.2015.2435158](https://doi.org/10.1109/TPWRD.2015.2435158).
- [10] G. P. Kumar and P. Jena, "Pearson's correlation coefficient for islanding detection using micro-PMU measurements," *IEEE Syst. J.*, vol. 15, no. 4, pp. 5078–5089, Dec. 2021, doi: [10.1109/JSYST.2020.3021922](https://doi.org/10.1109/JSYST.2020.3021922).
- [11] M. M. Ahmed and W. L. Soo, "Supervisory control and data acquisition system (SCADA) based customized remote terminal unit (RTU) for distribution automation system," in *Proc. IEEE 2nd Int. Power Energy Conf.*, Dec. 2008, pp. 1655–1660, doi: [10.1109/PECON.2008.4762744](https://doi.org/10.1109/PECON.2008.4762744).
- [12] F. Mango, M. Liserre, A. Dell'Aquila, and A. Pigazo, "Overview of anti-islanding algorithms for PV systems. Part I: Passive methods," in *Proc. 12th Int. Power Electron. Motion Control Conf.*, Aug. 2006, pp. 1878–1883.
- [13] A. I. M. Isa, H. Mohamad, and Z. M. Yasin, "Evaluation on non-detection zone of passive islanding detection techniques for synchronous distributed generation," in *Proc. IEEE Symp. Comput. Appl. Ind. Electron. (ISCAIE)*, Apr. 2015, pp. 100–104, doi: [10.1109/ISCAIE.2015.7298336](https://doi.org/10.1109/ISCAIE.2015.7298336).
- [14] J. C. M. Vieira, W. Freitas, W. Xu, and A. Morelato, "Efficient coordination of ROCOF and frequency relays for distributed generation protection by using the application region," *IEEE Trans. Power Del.*, vol. 21, no. 4, pp. 1878–1884, Oct. 2006, doi: [10.1109/TPWRD.2006.881588](https://doi.org/10.1109/TPWRD.2006.881588).
- [15] W.-Y. Chang, "An islanding detection method for grid-connected inverter of distributed renewable generation system," in *Proc. Asia-Pacific Power Energy Eng. Conf.*, Mar. 2011, pp. 1–4, doi: [10.1109/APPEEC.2011.5748897](https://doi.org/10.1109/APPEEC.2011.5748897).
- [16] B. Singam and L. Y. Hui, "Assessing SMS and PJD schemes of anti-islanding with varying quality factor," in *Proc. IEEE Int. Power Energy Conf.*, Nov. 2006, pp. 196–201, doi: [10.1109/pecon.2006.346645](https://doi.org/10.1109/pecon.2006.346645).
- [17] M. Ciobotaru, V. Agelidis, and R. Teodorescu, "Accurate and less-disturbing active anti-islanding method based on PLL for grid-connected PV inverters," in *Proc. IEEE Power Electron. Spec. Conf.*, Jun. 2008, pp. 4569–4576, doi: [10.1109/PESC.2008.4592685](https://doi.org/10.1109/PESC.2008.4592685).
- [18] F. De Mango, M. Liserre, and A. D. Aquila, "Overview of anti-islanding algorithms for PV systems. Part II: Active Methods," in *Proc. 12th Int. Power Electron. Motion Control Conf.*, Aug. 2006, pp. 1884–1889, doi: [10.1109/EPEPEMC.2006.4778680](https://doi.org/10.1109/EPEPEMC.2006.4778680).
- [19] M. Khodaparastan, H. Vahedi, F. Khazaeli, and H. Oraee, "A novel hybrid islanding detection method for inverter-based DGs using SFS and ROCOF," *IEEE Trans. Power Del.*, vol. 32, no. 5, pp. 2162–2170, Oct. 2017, doi: [10.1109/TPWRD.2015.2406577](https://doi.org/10.1109/TPWRD.2015.2406577).
- [20] V. Menon and M. H. Nehrir, "A hybrid islanding detection technique using voltage unbalance and frequency set point," *IEEE Trans. Power Syst.*, vol. 22, no. 1, pp. 442–448, Feb. 2007, doi: [10.1109/TPWRS.2006.887892](https://doi.org/10.1109/TPWRS.2006.887892).
- [21] H. Vahedi, A. Jalilvand, R. Noroozian, and G. B. Gharehpetian, "Islanding detection for inverter-based distributed generation using a hybrid SFS and  $Q-f$  method," *Int. Rev. Electr. Eng.*, vol. 5, no. 5, pp. 2280–2285, 2010.
- [22] P. Mahat, Z. Chen, and B. Bak-Jensen, "A hybrid islanding detection technique using average rate of voltage change and real power shift," *IEEE Trans. Power Del.*, vol. 24, no. 2, pp. 764–771, Apr. 2009, doi: [10.1109/TPWRD.2009.2013376](https://doi.org/10.1109/TPWRD.2009.2013376).
- [23] N. K. Swarnkar, O. P. Mahela, B. Khan, and M. Lalwani, "Identification of islanding events in utility grid with renewable energy penetration using current based passive method," *IEEE Access*, vol. 9, pp. 93781–93794, 2021, doi: [10.1109/ACCESS.2021.3092971](https://doi.org/10.1109/ACCESS.2021.3092971).
- [24] A. Hussain, C.-H. Kim, and M. S. Jabbar, "An intelligent deep convolutional neural networks-based islanding detection for multi-DG systems," *IEEE Access*, vol. 10, pp. 131920–131931, 2022, doi: [10.1109/ACCESS.2022.3229698](https://doi.org/10.1109/ACCESS.2022.3229698).
- [25] O. N. Faqhruldin, E. F. El-Saadany, and H. H. Zeineldin, "A universal islanding detection technique for distributed generation using pattern recognition," *IEEE Trans. Smart Grid*, vol. 5, no. 4, pp. 1985–1992, Jul. 2014, doi: [10.1109/TSG.2014.2302439](https://doi.org/10.1109/TSG.2014.2302439).
- [26] U. B. Irshad, M. S. Javaid, and M. A. Abido, "Novel anti-islanding algorithm for inverter-based distributed generation system," in *Proc. 9th IEEE-GCC Conf. Exhib. (GCCCE)*, May 2017, pp. 1–9, doi: [10.1109/IEEEGCC.2017.8448015](https://doi.org/10.1109/IEEEGCC.2017.8448015).
- [27] B. Matic-Cuka and M. Kezunovic, "Islanding detection for inverter-based distributed generation using support vector machine method," *IEEE Trans. Smart Grid*, vol. 5, no. 6, pp. 2676–2686, Nov. 2014, doi: [10.1109/TSG.2014.2338736](https://doi.org/10.1109/TSG.2014.2338736).
- [28] D. Mlakic, H. R. Baghaee, and S. Nikolovski, "A novel ANFIS-based islanding detection for inverter-interfaced microgrids," *IEEE Trans. Smart Grid*, vol. 10, no. 4, pp. 4411–4424, Jul. 2019, doi: [10.1109/TSG.2018.2859360](https://doi.org/10.1109/TSG.2018.2859360).
- [29] A. Ezzat, B. E. Elnaghi, and A. A. Abdelsalam, "Microgrids islanding detection using Fourier transform and machine learning algorithm," *Electr. Power Syst. Res.*, vol. 196, Jul. 2021, Art. no. 107224, doi: [10.1016/j.epr.2021.107224](https://doi.org/10.1016/j.epr.2021.107224).
- [30] B. Pangedaiah, P. L. S. K. Reddy, Y. P. Obulesu, V. R. Kota, and M. L. Alghaythi, "A robust passive islanding detection technique with zero-non-detection zone for inverter-interfaced distributed generation," *IEEE Access*, vol. 10, pp. 96296–96306, 2022, doi: [10.1109/ACCESS.2022.3204974](https://doi.org/10.1109/ACCESS.2022.3204974).
- [31] O. P. Mahela, Y. Sharma, S. Ali, B. Khan, and S. Padmanaban, "Estimation of islanding events in utility distribution grid with renewable energy using current variations and stockwell transform," *IEEE Access*, vol. 9, pp. 69798–69813, 2021, doi: [10.1109/ACCESS.2021.3078315](https://doi.org/10.1109/ACCESS.2021.3078315).

- [32] M. A. A. Farhan and K. S. Swarup, "Islanding detection scheme based on morphological wavelets," in *Proc. IEEE PES Asia-Pacific Power Energy Eng. Conf. (APPEEC)*, Nov. 2017, pp. 1–5, doi: [10.1109/APPEEC.2017.8308932](https://doi.org/10.1109/APPEEC.2017.8308932).
- [33] A. K. Singh and B. C. Pal, "Rate of change of frequency estimation for power systems using interpolated DFT and Kalman filter," *IEEE Trans. Power Syst.*, vol. 34, no. 4, pp. 2509–2517, Jul. 2019, doi: [10.1109/TPWRS.2018.2881151](https://doi.org/10.1109/TPWRS.2018.2881151).
- [34] B. Patnaik, M. Mishra, and R. K. Jena, "Variational mode decomposition-subspace-K-nearest neighbour based islanding detection in distributed generation system," *Int. Trans. Electr. Energy Syst.*, vol. 31, no. 6, pp. 1–21, Jun. 2021, doi: [10.1002/2050-7038.12900](https://doi.org/10.1002/2050-7038.12900).
- [35] B. K. Chaitanya, A. Yadav, and M. Pazoki, "An advanced signal decomposition technique for islanding detection in DG system," *IEEE Syst. J.*, vol. 15, no. 3, pp. 3220–3229, Sep. 2021, doi: [10.1109/JSYST.2020.3017157](https://doi.org/10.1109/JSYST.2020.3017157).
- [36] S. Dutta, P. K. Sadhu, M. Jaya Bharata Reddy, and D. K. Mohanta, "Shifting of research trends in islanding detection method—A comprehensive survey," *Protection Control Mod. Power Syst.*, vol. 3, no. 1, pp. 1–20, Dec. 2018, doi: [10.1186/s41601-017-0075-8](https://doi.org/10.1186/s41601-017-0075-8).
- [37] J. A. Cebollero, D. Cañete, S. Martín-Arroyo, M. García-Gracia, and H. Leite, "A survey of islanding detection methods for microgrids and assessment of non-detection zones in comparison with grid codes," *Energies*, vol. 15, no. 2, p. 460, Jan. 2022, doi: [10.3390/en15020460](https://doi.org/10.3390/en15020460).
- [38] A. Hussain, C.-H. Kim, and A. Mehdi, "A comprehensive review of intelligent islanding schemes and feature selection techniques for distributed generation system," *IEEE Access*, vol. 9, pp. 146603–146624, 2021, doi: [10.1109/ACCESS.2021.3123382](https://doi.org/10.1109/ACCESS.2021.3123382).
- [39] S. Raza, H. Mokhlis, H. Arof, J. A. Laghari, and L. Wang, "Application of signal processing techniques for islanding detection of distributed generation in distribution network: A review," *Energy Convers. Manage.*, vol. 96, pp. 613–624, May 2015, doi: [10.1016/j.enconman.2015.03.029](https://doi.org/10.1016/j.enconman.2015.03.029).
- [40] X. Guo, D. Xu, and B. Wu, "Overview of anti-islanding U.S. patents for grid-connected inverters," *Renew. Sustain. Energy Rev.*, vol. 40, pp. 311–317, Dec. 2014, doi: [10.1016/j.rser.2014.07.190](https://doi.org/10.1016/j.rser.2014.07.190).
- [41] *Sistemas Fotovoltaicos (FV)-Características da Interface de Conexão Com a Rede Elétrica de Distribuição*, ABNT NBR, Brasília, Brasil, 2013, pp. 1–12.
- [42] (Jul. 2018). *IEEE Standard for Interconnection and Interoperability of Distributed Energy Resources With Associated Electric Power Systems Interfaces*, doi: [10.1109/IEEESTD.2018.8332112](https://doi.org/10.1109/IEEESTD.2018.8332112).
- [43] *Inverters, Converters, Controllers and Interconnection System Equipment for Use With Distributed Energy Resources*, Underwriters Laboratories Inc. (UL), London, U.K., pp. 1–258, 2022.
- [44] W. Feng. (2009). *A DSP-Based AC Electronic Load for Unintentional Islanding Tests*. [Online]. Available: <https://open.library.ubc.ca/soa/cIRcle/collections/ubctheses/24/items/1.0067479>
- [45] L. Dalla Santa, T. Caldognetto, P. Magnone, and P. Mattavelli, "Implementation of an active RLC load for unintentional islanding test," in *Proc. 18th Eur. Conf. Power Electron. Appl.*, Sep. 2016, pp. 3–10, doi: [10.1109/epe.2016.7695653](https://doi.org/10.1109/epe.2016.7695653).
- [46] Ê. C. Resende, H. T. de Moura Carvalho, and L. C. G. Freitas, "Implementation and critical analysis of the active phase jump with positive feedback anti-islanding algorithm," *Energies*, vol. 15, no. 13, p. 4609, Jun. 2022, doi: [10.3390/en15134609](https://doi.org/10.3390/en15134609).
- [47] R. Teodorescu, M. Liserre, and P. Rodríguez, "Islanding detection," in *Grid Converters for Photovoltaic and Wind Power Systems*. Hoboken, NJ, USA: Wiley, 2011, pp. 93–122, doi: [10.1002/9780470667057.ch5](https://doi.org/10.1002/9780470667057.ch5).
- [48] M. E. Ropp, M. Begovic, A. Rohatgi, G. A. Kern, R. H. Bonn, and S. Gonzalez, "Determining the relative effectiveness of islanding detection methods using phase criteria and nondetection zones," *IEEE Trans. Energy Convers.*, vol. 15, no. 3, pp. 290–296, 2000, doi: [10.1109/60.875495](https://doi.org/10.1109/60.875495).
- [49] L. A. C. Lopes and H. Sun, "Performance assessment of active frequency drifting islanding detection methods," *IEEE Trans. Energy Convers.*, vol. 21, no. 1, pp. 171–180, Mar. 2006, doi: [10.1109/TEC.2005.859981](https://doi.org/10.1109/TEC.2005.859981).
- [50] F. Liu, Y. Kang, and S. Duan, "Analysis and optimization of active frequency drift islanding detection method," in *Proc. 22nd Annu. IEEE Appl. Power Electron. Conf. Expo.*, Feb. 2007, pp. 1379–1384, doi: [10.1109/APEX.2007.357696](https://doi.org/10.1109/APEX.2007.357696).
- [51] A. Ellis, S. Gonzalez, Y. Miyamoto, M. Ropp, D. Schutz, and T. Sato, "Comparative analysis of anti-islanding requirements and test procedures in the United States and Japan," in *Proc. IEEE 39th Photovolt. Spec. Conf. (PVSC)*, Jun. 2013, pp. 3134–3140, doi: [10.1109/PVSC.2013.6745122](https://doi.org/10.1109/PVSC.2013.6745122).
- [52] A. Kitamura, M. Okamoto, F. Yamamoto, K. Nakaji, H. Matsuda, and K. Hotta, "Islanding phenomenon elimination study at rokko test center," in *Proc. IEEE 1st World Conf. Photovolt. Energy Convers.*, Feb. 1994, pp. 18–21, doi: [10.1109/WCPEC.1994.520070](https://doi.org/10.1109/WCPEC.1994.520070).
- [53] N. C. Thompson, K. Greenwald, K. Lee, and G. F. Manso, "Deep learning's diminishing returns: The cost of improvement is becoming unsustainable," *IEEE Spectr.*, vol. 58, no. 10, pp. 50–55, Oct. 2021, doi: [10.1109/MSPEC.2021.9563954](https://doi.org/10.1109/MSPEC.2021.9563954).
- [54] X. Wang and W. Freitas, "Impact of positive-feedback anti-islanding methods on small-signal stability of inverter-based distributed generation," *IEEE Trans. Energy Convers.*, vol. 23, no. 3, pp. 923–931, Sep. 2008, doi: [10.1109/TEC.2008.926066](https://doi.org/10.1109/TEC.2008.926066).
- [55] F. Valsamas, D. Voglitsis, N. Rigogiannis, N. Papanikolaou, and A. Kyritsis, "Comparative study of active anti-islanding schemes compatible with MICs in the prospect of high penetration levels and weak grid conditions," *IET Gener., Transmiss. Distrib.*, vol. 12, no. 20, pp. 4589–4596, Nov. 2018, doi: [10.1049/iet-gtd.2018.5636](https://doi.org/10.1049/iet-gtd.2018.5636).
- [56] M. Xu, R. V. N. Melnik, and U. Borup, "Modeling anti-islanding protection devices for photovoltaic systems," *Renew. Energy*, vol. 29, no. 15, pp. 2195–2216, Dec. 2004, doi: [10.1016/j.renene.2004.04.005](https://doi.org/10.1016/j.renene.2004.04.005).
- [57] H. H. Zeineldin and S. Kennedy, "Sandia frequency-shift parameter selection to eliminate nondetection zones," *IEEE Trans. Power Del.*, vol. 24, no. 1, pp. 486–487, Jan. 2009, doi: [10.1109/TPWRD.2008.2005362](https://doi.org/10.1109/TPWRD.2008.2005362).
- [58] H. H. Zeineldin and S. Conti, "Sandia frequency shift parameter selection for multi-inverter systems to eliminate non-detection zone," *IET Renew. Power Gener.*, vol. 5, no. 2, p. 175, 2011, doi: [10.1049/iet-rpg.2010.0096](https://doi.org/10.1049/iet-rpg.2010.0096).
- [59] D. Voglitsis, F. Valsamas, N. Rigogiannis, and N. P. Papanikolaou, "On harmonic injection anti-islanding techniques under the operation of multiple DER-inverters," *IEEE Trans. Energy Convers.*, vol. 34, no. 1, pp. 455–467, Mar. 2019, doi: [10.1109/TEC.2018.2881737](https://doi.org/10.1109/TEC.2018.2881737).
- [60] D. Velasco, C. Trujillo, G. Garcera, and E. Figueres, "An active anti-islanding method based on phase-PLL perturbation," *IEEE Trans. Power Electron.*, vol. 26, no. 4, pp. 1056–1066, Apr. 2011, doi: [10.1109/TPEL.2010.2089643](https://doi.org/10.1109/TPEL.2010.2089643).
- [61] A. Cardenas, K. Agbossou, and M. L. Doubbia, "Performance evaluation of active anti-islanding scheme for multi-inverter DG systems," in *Proc. 9th Int. Conf. Environ. Electr. Eng.*, May 2010, pp. 218–221, doi: [10.1109/EEEIC.2010.5489946](https://doi.org/10.1109/EEEIC.2010.5489946).
- [62] M. Liu, W. Zhao, S. Huang, Q. Wang, and K. Shi, "Problems in the classic frequency shift islanding detection methods applied to energy storage converters and a coping strategy," *IEEE Trans. Energy Convers.*, vol. 33, no. 2, pp. 496–505, Jun. 2018, doi: [10.1109/TEC.2017.2761851](https://doi.org/10.1109/TEC.2017.2761851).
- [63] C. Zheng, Y. Sun, B. Guo, T. Jiang, W. Feng, X. Zhang, and J. M. Guerrero, "Trade-off design of positive-feedback based islanding detection," *Int. Trans. Electr. Energy Syst.*, vol. 30, no. 12, pp. 1–20, Dec. 2020, doi: [10.1002/2050-7038.12654](https://doi.org/10.1002/2050-7038.12654).
- [64] H. Kobayashi, K. Takigawa, E. Hashimoto, A. Kitamura, and H. Matsuda, "Method for preventing islanding phenomenon on utility grid with a number of small scale PV systems," in *Proc. Conf. Rec. 22nd IEEE Photovolt. Spec. Conf.*, Feb. 1991, pp. 695–700, doi: [10.1109/PVSC.1991.169299](https://doi.org/10.1109/PVSC.1991.169299).
- [65] A. Kitamura, M. Okamoto, F. Yamamoto, K. Nakaji, H. Matsuda, and K. Hotta, "Islanding phenomenon elimination study at rokko test center," in *Proc. IEEE 1st World Conf. Photovolt. Energy Convers.*, Mar. 2014, pp. 759–762, doi: [10.1109/WCPEC.1994.520070](https://doi.org/10.1109/WCPEC.1994.520070).
- [66] C. Li, J. Savulak, and R. Reinmuller, "Unintentional islanding of distributed generation—Operating experiences from naturally occurred events," *IEEE Trans. Power Del.*, vol. 29, no. 1, pp. 269–274, Feb. 2014, doi: [10.1109/TPWRD.2013.2282264](https://doi.org/10.1109/TPWRD.2013.2282264).
- [67] A. Poluektov, A. Pinomaa, J. Ahola, and A. Kosonen, "Designing a power-line-communication-based LoM protection concept with application of software-defined radios," in *Proc. Int. Symp. Power Line Commun. Appl.*, Feb. 2016, pp. 156–161, doi: [10.1109/ISPLC.2016.7476286](https://doi.org/10.1109/ISPLC.2016.7476286).
- [68] R. Benato, R. Caldon, and F. Cesena, "Carrier signal-based protection to prevent dispersed generation islanding on mv systems," in *Proc. 17th Int. Conf. Electr. Distrib.*, no. 48, 2003, pp. 1–7.
- [69] A. Cataliotti, V. Cosentino, D. Di Cara, P. Russotto, and G. Tinè, "On the use of narrow band power line as communication technology for medium and low voltage smart grids," in *Proc. IEEE Int. Instrum. Meas. Technol. Conf.*, May 2012, pp. 619–623, doi: [10.1109/I2MTC.2012.6229503](https://doi.org/10.1109/I2MTC.2012.6229503).
- [70] A. Poluektov, A. Romanenko, A. Pinomaa, J. Ahola, and A. Kosonen, "Sensitivity analysis of a PLC-based anti-islanding solution using DSSS," in *Proc. IEEE Int. Symp. Power Line Commun. Appl.*, Feb. 2017, pp. 1–6, doi: [10.1109/ISPLC.2017.7897117](https://doi.org/10.1109/ISPLC.2017.7897117).

- [71] W. Bower, "Evaluation of islanding detection methods for photovoltaic utility-interactive power system," in *Proc. Int. Energy Agency Implement. Agreem. Photovolt. Power Syst.*, 2002, p. 59. [Online]. Available: [https://iea-pvps.org/wp-content/uploads/2020/01/rep5\\_09.pdf](https://iea-pvps.org/wp-content/uploads/2020/01/rep5_09.pdf)
- [72] P. R. Bedse and N. N. Jangle, "Review on PMU using recursive DFT algorithm," in *Proc. Int. Conf. Comput., Power Commun. Technol. (GUCON)*, Sep. 2018, pp. 375–377, doi: [10.1109/GUCON.2018.8675049](https://doi.org/10.1109/GUCON.2018.8675049).
- [73] A. Borghetti, C. A. Nucci, M. Paolone, G. Ciappi, and A. Solari, "Synchronized phasors monitoring during the islanding maneuver of an active distribution network," *IEEE Trans. Smart Grid*, vol. 2, no. 1, pp. 82–91, Mar. 2011, doi: [10.1109/TSG.2010.2094213](https://doi.org/10.1109/TSG.2010.2094213).
- [74] Z. Lin, T. Xia, Y. Ye, Y. Zhang, L. Chen, Y. Liu, K. Tomsovic, T. Bilke, and F. Wen, "Application of wide area measurement systems to islanding detection of bulk power systems," *IEEE Trans. Power Syst.*, vol. 28, no. 2, pp. 2006–2015, May 2013, doi: [10.1109/TPWRS.2013.2250531](https://doi.org/10.1109/TPWRS.2013.2250531).
- [75] R. Sun and V. A. Centeno, "Wide area system islanding contingency detecting and warning scheme," *IEEE Trans. Power Syst.*, vol. 29, no. 6, pp. 2581–2589, Nov. 2014, doi: [10.1109/TPWRS.2014.2317802](https://doi.org/10.1109/TPWRS.2014.2317802).
- [76] T. Werho, V. Vittal, S. Kolluri, and S. M. Wong, "A potential island formation identification scheme supported by PMU measurements," *IEEE Trans. Power Syst.*, vol. 31, no. 1, pp. 423–431, Jan. 2016, doi: [10.1109/TPWRS.2015.2402130](https://doi.org/10.1109/TPWRS.2015.2402130).
- [77] D. Kumar and P. S. Bhowmik, "Artificial neural network and phasor data-based islanding detection in smart grid," *IET Gener., Transmiss. Distrib.*, vol. 12, no. 21, pp. 5843–5850, Nov. 2018, doi: [10.1049/iet-gtd.2018.6299](https://doi.org/10.1049/iet-gtd.2018.6299).
- [78] D. Kumar and P. S. Bhowmik, "Hidden Markov model based islanding prediction in smart grids," *IEEE Syst. J.*, vol. 13, no. 4, pp. 4181–4189, Dec. 2019, doi: [10.1109/JSYST.2019.2911055](https://doi.org/10.1109/JSYST.2019.2911055).
- [79] A. von Meier, D. Culler, A. McEachern, and R. Arghandeh, "Micro-synchrophasors for distribution systems," in *Proc. ISGT*, Feb. 2014, pp. 1–5, doi: [10.1109/ISGT.2014.6816509](https://doi.org/10.1109/ISGT.2014.6816509).
- [80] E. Dusabimana and S.-G. Yoon, "A survey on the micro-phasor measurement unit in distribution networks," *Electronics*, vol. 9, no. 2, p. 305, Feb. 2020, doi: [10.3390/electronics9020305](https://doi.org/10.3390/electronics9020305).
- [81] K. Subramanian and A. K. Loganathan, "Islanding detection using a micro-synchrophasor for distribution systems with distributed generation," *Energies*, vol. 13, no. 19, p. 5180, Oct. 2020, doi: [10.3390/en13195180](https://doi.org/10.3390/en13195180).
- [82] A. Shukla, S. Dutta, and P. K. Sadhu, "An island detection approach by  $\mu$ -PMU with reduced chances of cyber attack," *Int. J. Electr. Power Energy Syst.*, vol. 126, Mar. 2021, Art. no. 106599, doi: [10.1016/j.ijepes.2020.106599](https://doi.org/10.1016/j.ijepes.2020.106599).
- [83] *IEEE Standard for Electrical Power System Device Function Numbers, Acronyms, and Contact Designations*, IEEE, Piscataway, NJ, USA, Oct. 2008.
- [84] A. Abokhalil, A. Awan, and A.-R. Al-Qawsmi, "Comparative study of passive and active islanding detection methods for PV grid-connected systems," *Sustainability*, vol. 10, no. 6, p. 1798, May 2018, doi: [10.3390/su10061798](https://doi.org/10.3390/su10061798).
- [85] A. S. Aljankawey, W. G. Morsi, L. Chang, and C. P. Diduch, "Passive method-based islanding detection of renewable-based distributed generation: The issues," in *Proc. IEEE Electr. Power Energy Conf.*, Aug. 2010, pp. 1–12, doi: [10.1109/EPEC.2010.5697253](https://doi.org/10.1109/EPEC.2010.5697253).
- [86] Y. Yoshida and H. Suzuki, "Impacts of rectifier circuit loads on islanding detection of photovoltaic systems," in *Proc. Int. Power Electron. Conf.*, May 2014, pp. 3503–3508, doi: [10.1109/IPEC.2014.6869999](https://doi.org/10.1109/IPEC.2014.6869999).
- [87] M. A. Elgendy, D. J. Atkinson, M. Armstrong, and S. M. Gadoue, "Impact of grid background harmonics on inverter-based islanding detection algorithms," *Proc. Int. Conf. Power Electron. Drive Syst.*, Jun. 2015, pp. 67–72, doi: [10.1109/PEDS.2015.7203480](https://doi.org/10.1109/PEDS.2015.7203480).
- [88] S.-I. Jang and K.-H. Kim, "An islanding detection method for distributed generations using voltage unbalance and total harmonic distortion of current," *IEEE Trans. Power Del.*, vol. 19, no. 2, pp. 745–752, Apr. 2004, doi: [10.1109/TPWRD.2003.822964](https://doi.org/10.1109/TPWRD.2003.822964).
- [89] H. Laaksonen, "Advanced islanding detection functionality for future electricity distribution networks," *IEEE Trans. Power Del.*, vol. 28, no. 4, pp. 2056–2064, Oct. 2013, doi: [10.1109/TPWRD.2013.2271317](https://doi.org/10.1109/TPWRD.2013.2271317).
- [90] G. Wang and S. University, "Design consideration and performance analysis of a hybrid islanding detection method combining voltage unbalance/total harmonic distortion and bilateral reactive power variation," *CPSS Trans. Power Electron. Appl.*, vol. 5, no. 1, pp. 86–100, Mar. 2020, doi: [10.24295/cpsstpea.2020.00008](https://doi.org/10.24295/cpsstpea.2020.00008).
- [91] D. Mlagic, H. R. Baghaee, and S. Nikolovski, "Gibbs phenomenon-based hybrid islanding detection strategy for VSC-based microgrids using frequency shift,  $THD_U$ , and  $RMS_U$ ," *IEEE Trans. Smart Grid*, vol. 10, no. 5, pp. 5479–5491, Sep. 2019, doi: [10.1109/TSG.2018.2883595](https://doi.org/10.1109/TSG.2018.2883595).
- [92] M. Liserre, A. Pigazo, A. Dell'Aquila, and V. M. Moreno, "An anti-islanding method for single-phase inverters based on a grid voltage sensorless control," *IEEE Trans. Ind. Electron.*, vol. 53, no. 5, pp. 1418–1426, Oct. 2006, doi: [10.1109/TIE.2006.882003](https://doi.org/10.1109/TIE.2006.882003).
- [93] K. Colombage, J. Wang, C. Gould, and C. Liu, "PWM harmonic signature-based islanding detection for a single-phase inverter with PWM frequency hopping," *IEEE Trans. Ind. Appl.*, vol. 53, no. 1, pp. 411–419, Jan. 2017, doi: [10.1109/TIA.2016.2611671](https://doi.org/10.1109/TIA.2016.2611671).
- [94] D. D. Reigosa, F. Briz, C. B. Charro, and J. M. Guerrero, "Passive islanding detection using inverter nonlinear effects," *IEEE Trans. Power Electron.*, vol. 32, no. 11, pp. 8434–8445, Nov. 2017, doi: [10.1109/TPEL.2016.2646751](https://doi.org/10.1109/TPEL.2016.2646751).
- [95] A. A. Abdelsalam, A. A. Salem, E. S. Oda, and A. A. Eldesouky, "Islanding detection of microgrid incorporating inverter based DGs using long short-term memory network," *IEEE Access*, vol. 8, pp. 106471–106486, 2020, doi: [10.1109/ACCESS.2020.3000872](https://doi.org/10.1109/ACCESS.2020.3000872).
- [96] S. P. Chowdhury, S. Chowdhury, and P. A. Crossley, "Islanding protection of active distribution networks with renewable distributed generators: A comprehensive survey," *Electr. Power Syst. Res.*, vol. 79, no. 6, pp. 984–992, Jun. 2009, doi: [10.1016/j.epsr.2008.12.012](https://doi.org/10.1016/j.epsr.2008.12.012).
- [97] C. F. Ten and P. A. Crossley, "Evaluation of ROCOF relay performances on networks with distributed generation," in *Proc. IET 9th Int. Conf. Develop. Power Syst. Protection (DPSP)*, 2008, pp. 522–527, doi: [10.1049/cp:20080092](https://doi.org/10.1049/cp:20080092).
- [98] J. A. de la O Serna, "Synchrophasor measurement with polynomial phase-locked-loop Taylor–Fourier filters," *IEEE Trans. Instrum. Meas.*, vol. 64, no. 2, pp. 328–337, Feb. 2015, doi: [10.1109/TIM.2014.2344333](https://doi.org/10.1109/TIM.2014.2344333).
- [99] G. Frigo, A. Derviškić, Y. Zuo, and M. Paolone, "PMU-based ROCOF measurements: Uncertainty limits and metrological significance in power system applications," *IEEE Trans. Instrum. Meas.*, vol. 68, no. 10, pp. 3810–3822, Oct. 2019, doi: [10.1109/TIM.2019.2907756](https://doi.org/10.1109/TIM.2019.2907756).
- [100] Z. Wang, J. Xiong, and X. Wang, "Investigation of frequency oscillation caused false trips for biomass distributed generation," *IEEE Trans. Smart Grid*, vol. 10, no. 6, pp. 6092–6101, Nov. 2019, doi: [10.1109/TSG.2019.2896480](https://doi.org/10.1109/TSG.2019.2896480).
- [101] B. Liu and D. Thomas, "New islanding detection method for DFIG wind turbines," in *Proc. 4th Int. Conf. Electric Utility Deregulation Restructuring Power Technol. (DRPT)*, Jul. 2011, pp. 213–217, doi: [10.1109/DRPT.2011.5993891](https://doi.org/10.1109/DRPT.2011.5993891).
- [102] K. Jia, T. Bi, B. Liu, D. Thomas, and A. Goodman, "Advanced islanding detection utilized in distribution systems with DFIG," *Int. J. Electr. Power Energy Syst.*, vol. 63, pp. 113–123, Dec. 2014, doi: [10.1016/j.ijepes.2014.05.003](https://doi.org/10.1016/j.ijepes.2014.05.003).
- [103] M. Grebla, J. R. A. K. Yellajosula, and H. K. Høidalen, "Adaptive frequency estimation method for ROCOF islanding detection relay," *IEEE Trans. Power Del.*, vol. 35, no. 4, pp. 1867–1875, Aug. 2020, doi: [10.1109/TPWRD.2019.2956200](https://doi.org/10.1109/TPWRD.2019.2956200).
- [104] B. Liu, X. Ni, G. Yan, B. Li, and K. Jia, "Performance of ROCOF protection in PV system," in *Proc. IEEE PES Asia-Pacific Power Energy Eng. Conf. (APPEEC)*, Oct. 2016, pp. 454–457, doi: [10.1109/APPEEC.2016.7779545](https://doi.org/10.1109/APPEEC.2016.7779545).
- [105] M. W. Altaf, M. T. Arif, S. Saha, S. N. Islam, M. E. Haque, and A. M. T. Oo, "Effective ROCOF based islanding detection technique for different types of microgrid," in *Proc. IEEE Ind. Appl. Soc. Annu. Meeting (IAS)*, Oct. 2021, pp. 1–8, doi: [10.1109/IAS48185.2021.9677270](https://doi.org/10.1109/IAS48185.2021.9677270).
- [106] S. Akhlaghi, A. Akhlaghi, and A. A. Ghadimi, "Performance analysis of the slip mode frequency shift islanding detection method under different inverter interface control strategies," in *Proc. IEEE Power Energy Conf. Illinois (PECI)*, Feb. 2016, pp. 1–7, doi: [10.1109/PECI.2016.7459250](https://doi.org/10.1109/PECI.2016.7459250).
- [107] O. Raipala, A. Mäkinen, S. Repo, and P. Järventausta, "An anti-islanding protection method based on reactive power injection and ROCOF," *IEEE Trans. Power Del.*, vol. 32, no. 1, pp. 401–410, Feb. 2017, doi: [10.1109/TPWRD.2016.2543503](https://doi.org/10.1109/TPWRD.2016.2543503).
- [108] P. Gupta, R. S. Bhatia, and D. K. Jain, "Active ROCOF relay for islanding detection," *IEEE Trans. Power Del.*, vol. 32, no. 1, pp. 420–429, Feb. 2017, doi: [10.1109/TPWRD.2016.2540723](https://doi.org/10.1109/TPWRD.2016.2540723).
- [109] O. Arguene, F. Cadoux, B. Raison, and L. De Alvaro, "Non-detection zone of an anti-islanding protection with rate of change of frequency threshold," *CIRE-Open Access Proc. J.*, vol. 2017, no. 1, pp. 1338–1341, Oct. 2017, doi: [10.1049/oap-cired.2017.0352](https://doi.org/10.1049/oap-cired.2017.0352).

- [110] M. R. Alam, M. T. A. Begum, and K. M. Muttaqi, "Assessing the performance of ROCOF relay for anti-islanding protection of distributed generation under subcritical region of power imbalance," *IEEE Trans. Ind. Appl.*, vol. 55, no. 5, pp. 5395–5405, Sep. 2019, doi: [10.1109/TIA.2019.2927667](https://doi.org/10.1109/TIA.2019.2927667).
- [111] J. Sneath and A. D. Rajapakse, "Fault detection and interruption in an earthed HVDC grid using ROCOV and hybrid DC breakers," *IEEE Trans. Power Del.*, vol. 31, no. 3, pp. 973–981, Jun. 2016, doi: [10.1109/TPWRD.2014.2364547](https://doi.org/10.1109/TPWRD.2014.2364547).
- [112] M. J. Perez-Molina, P. Eguia-Lopez, M. Larruskain-Eskobal, A. Etxegarai-Madina, and S. Apiñaniz Apiñaniz, "Fault detection based on ROCOV in a multi-terminal HVDC grid," *Renew. Energy Power Quality J.*, vol. 18, pp. 167–171, Jun. 2020, doi: [10.24084/repqj18.260](https://doi.org/10.24084/repqj18.260).
- [113] A. Makkieh, A. Florida-James, D. Tzelepis, A. Emhemed, G. Burt, S. Strachau, and A. Junyent-Ferre, "Assessment of passive islanding detection methods for DC microgrids," in *Proc. 15th IET Int. Conf. AC DC Power Transmiss. (ACDC)*, Feb. 2019, pp. 1–6, doi: [10.1049/cp.2019.0016](https://doi.org/10.1049/cp.2019.0016).
- [114] R. Bakhshi-Jafarabadi, J. Sadeh, J. de J. Chavez, and M. Popov, "Two-level islanding detection method for grid-connected photovoltaic system-based microgrid with small non-detection zone," *IEEE Trans. Smart Grid*, vol. 12, no. 2, pp. 1063–1072, Mar. 2021, doi: [10.1109/TSG.2020.3035126](https://doi.org/10.1109/TSG.2020.3035126).
- [115] M. Seyedi, S. A. Taher, B. Ganji, and J. Guerrero, "A hybrid islanding detection method based on the rates of changes in voltage and active power for the multi-inverter systems," *IEEE Trans. Smart Grid*, vol. 12, no. 4, pp. 2800–2811, Jul. 2021, doi: [10.1109/TSG.2021.3061567](https://doi.org/10.1109/TSG.2021.3061567).
- [116] M. A. Dawoud, D. K. Ibrahim, M. I. Gilany, and A. El'Gharably, "Proposed application for rate of change of phasor voltage in fault detection and coordination studies in MV distribution networks," *Iranian J. Sci. Technol., Trans. Electr. Eng.*, vol. 45, no. 3, pp. 815–831, Sep. 2021, doi: [10.1007/s40998-020-00402-9](https://doi.org/10.1007/s40998-020-00402-9).
- [117] M. A. Dawoud, D. K. Ibrahim, M. I. Gilany, and A. El'Gharably, "Robust coordination scheme for microgrids protection based on the rate of change of voltage," *IEEE Access*, vol. 9, pp. 156283–156296, 2021, doi: [10.1109/ACCESS.2021.3128999](https://doi.org/10.1109/ACCESS.2021.3128999).
- [118] A. Samui and S. R. Samantaray, "Assessment of ROCPAD relay for islanding detection in distributed generation," *IEEE Trans. Smart Grid*, vol. 2, no. 2, pp. 391–398, Jun. 2011, doi: [10.1109/TSG.2011.2125804](https://doi.org/10.1109/TSG.2011.2125804).
- [119] A. Abyaz, H. Panahi, R. Zamani, H. Haes Alhelou, P. Siano, M. Shafiekhah, and M. Parente, "An effective passive islanding detection algorithm for distributed generations," *Energies*, vol. 12, no. 16, p. 3160, Aug. 2019, doi: [10.3390/en12163160](https://doi.org/10.3390/en12163160).
- [120] M. A. Redfern, J. Barrett, and O. Usta, "A new microprocessor based islanding protection algorithm for dispersed storage and generation units," *IEEE Trans. Power Del.*, vol. 10, no. 3, pp. 1249–1254, Jul. 1995, doi: [10.1109/61.400903](https://doi.org/10.1109/61.400903).
- [121] M. R. Alam, K. M. Muttaqi, and A. Bouzardoum, "A short length window-based method for islanding detection in distributed generation," in *Proc. Int. Joint Conf. Neural Netw. (IJCNN)*, Jun. 2012, pp. 1–6, doi: [10.1109/IJCNN.2012.6252483](https://doi.org/10.1109/IJCNN.2012.6252483).
- [122] F. S. Pai and S. J. Huang, "A detection algorithm for islanding-prevention of dispersed consumer-owned storage and generating units," *IEEE Power Eng. Rev.*, vol. 21, no. 12, p. 67, Dec. 2001, doi: [10.1109/MPER.2001.4311227](https://doi.org/10.1109/MPER.2001.4311227).
- [123] C. R. Reddy and K. H. Reddy, "Islanding detection method for inverter based distributed generation based on combined changes of rocoap and rocorp," *Int. J. Pure Appl. Math.*, vol. 117, no. 19, pp. 433–440, 2017. [Online]. Available: <http://www.ijpam.eu>
- [124] M. E. Ropp, M. Begovic, and A. Rohatgi, "Prevention of islanding in grid-connected photovoltaic systems," *Prog. Photovolt. Res. Appl.*, vol. 7, no. 1, pp. 39–59, Jan. 1999.
- [125] A. Yafaoui, B. Wu, and S. Kouro, "Improved active frequency drift anti-islanding method with lower total harmonic distortion," in *Proc. 36th Annu. Conf. IEEE Ind. Electron. Soc.*, Nov. 2010, pp. 3216–3221, doi: [10.1109/IECON.2010.5675051](https://doi.org/10.1109/IECON.2010.5675051).
- [126] W. Chen, G. J. Wang, and W. Jiang, "An improved active frequency drift islanding detection method with lower total harmonic distortion," *Power Syst. Prot. Control*, vol. 41, no. 24, pp. 107–111, 2013.
- [127] Y. Jung, J. Choi, B. Yu, G. Yu, J. So, and J. Choi, "A novel active frequency drift method of islanding prevention for the grid-connected photovoltaic inverter," in *Proc. IEEE Annu. Power Electron. Spec. Conf.*, Feb. 2005, pp. 1915–1921, doi: [10.1109/PESC.2005.1581893](https://doi.org/10.1109/PESC.2005.1581893).
- [128] M. G. L. Yuan, X. -F. Zhang, and J. -Y. Zheng, "An improved islanding detection method for grid-connected photovoltaic inverters," in *Proc. Int. Power Eng. Conf.*, Feb. 2007, pp. 538–543. [Online]. Available: <https://ieeexplore.ieee.org/document/4510087>
- [129] Ê. C. Resende, H. T. M. Carvalho, A. Ernane, A. Coelho, and L. C. De, "Proposta de uma nova estratégia ativa de anti-ilhamento baseada em realimentação positiva de frequência," *Brazilian J. Power Electron.*, vol. 26, no. 3, pp. 302–314, 2021. [Online]. Available: <https://sobrap.org.br/site/uploads/2021/09/rvol26no03-11-0007-302-314.pdf>
- [130] H. Vahedi, M. Karrari, and G. B. Gharehpetian, "Accurate SFS parameter design criterion for inverter-based distributed generation," *IEEE Trans. Power Del.*, vol. 31, no. 3, pp. 1050–1059, Jun. 2016, doi: [10.1109/TPWRD.2015.2391193](https://doi.org/10.1109/TPWRD.2015.2391193).
- [131] X. Wang, W. Freitas, and W. Xu, "Dynamic non-detection zones of positive feedback anti-islanding methods for inverter-based distributed generators," *IEEE Trans. Power Del.*, vol. 26, no. 2, pp. 1145–1155, Apr. 2011, doi: [10.1109/TPWRD.2010.2090672](https://doi.org/10.1109/TPWRD.2010.2090672).
- [132] M. Al Hosani, Z. Qu, and H. H. Zeineldin, "Scheduled perturbation to reduce nondetection zone for low gain Sandia frequency shift method," *IEEE Trans. Smart Grid*, vol. 6, no. 6, pp. 3095–3103, Nov. 2015, doi: [10.1109/TSG.2015.2423554](https://doi.org/10.1109/TSG.2015.2423554).
- [133] H. Vahedi and M. Karrari, "Adaptive fuzzy Sandia frequency-shift method for islanding protection of inverter-based distributed generation," *IEEE Trans. Power Del.*, vol. 28, no. 1, pp. 84–92, Jan. 2013, doi: [10.1109/TPWRD.2012.2219628](https://doi.org/10.1109/TPWRD.2012.2219628).
- [134] A. Y. Hatata, E.-H. Abd-Raboh, and B. E. Sedhom, "Proposed Sandia frequency shift for anti-islanding detection method based on artificial immune system," *Alexandria Eng. J.*, vol. 57, no. 1, pp. 235–245, Mar. 2018, doi: [10.1016/j.aej.2016.12.020](https://doi.org/10.1016/j.aej.2016.12.020).
- [135] G.-K. Hung, C.-C. Chang, and C.-L. Chen, "Automatic phase-shift method for islanding detection of grid-connected photovoltaic inverters," *IEEE Trans. Energy Convers.*, vol. 18, no. 1, pp. 169–173, Mar. 2003, doi: [10.1109/TEC.2002.808412](https://doi.org/10.1109/TEC.2002.808412).
- [136] B. Mohammadpour, M. Pahlevaninezhad, S. M. Kaviri, and P. Jain, "A new slip mode frequency shift islanding detection method for single phase grid connected inverters," in *Proc. IEEE 7th Int. Symp. Power Electron. Distrib. Gener. Syst. (PEDG)*, Jun. 2016, pp. 1–7, doi: [10.1109/PEDG.2016.7527029](https://doi.org/10.1109/PEDG.2016.7527029).
- [137] S. Bifaretti, A. Lidozzi, L. Solero, and F. Crescimbeni, "Anti-islanding detector based on a robust PLL," *IEEE Trans. Ind. Appl.*, vol. 51, no. 1, pp. 398–405, Jan. 2015, doi: [10.1109/TIA.2014.2330063](https://doi.org/10.1109/TIA.2014.2330063).
- [138] S. Akhlaghi, A. A. Ghadimi, and A. Akhlaghi, "A novel hybrid islanding detection method combination of SMS and Q-f for islanding detection of inverter-based DG," in *Proc. Power Energy Conf. Illinois (PECI)*, Feb. 2014, pp. 1–8, doi: [10.1109/PECI.2014.6804571](https://doi.org/10.1109/PECI.2014.6804571).
- [139] M. Brito, M. Alves, L. Sampaio, and C. Canesin, "Estratégias de anti-ilhamento aplicadas a sistemas de geração distribuída fotovoltaica," *Eletrônica Potência*, vol. 23, no. 2, pp. 226–234, 2018.
- [140] E. Vazquez, N. Vazquez, and R. Femat, "Modified Sandia voltage shift anti-islanding scheme for distributed power generator systems," *IET Power Electron.*, vol. 13, no. 18, pp. 4226–4234, Dec. 2020, doi: [10.1049/iet-pel.2020.0735](https://doi.org/10.1049/iet-pel.2020.0735).
- [141] H. T. da Silva, "Estudo sobre a interação de métodos anti-ilhamento com múltiplos inversores para sistemas fotovoltaicos conectados à rede de distribuição de baixa tensão," M.S. thesis, PEA, USP, São Paulo, Brazil, 2016. [Online]. Available: <http://www.teses.usp.br/teses/disponiveis/3/3143/tde-28062016-151006/>
- [142] H. H. Zeineldin, E. F. El-Saadany, and M. M. A. Salama, "Islanding detection of inverter-based distributed generation," *IEEE Proc.-Gener. Transmiss. Distrib.*, vol. 153, no. 6, p. 644, 2006, doi: [10.1049/ip-gtd:20050429](https://doi.org/10.1049/ip-gtd:20050429).
- [143] H. H. Zeineldin, "A Q-F droop curve for facilitating islanding detection of inverter-based distributed generation," *IEEE Trans. Power Electron.*, vol. 24, no. 3, pp. 665–673, Mar. 2009, doi: [10.1109/TPEL.2008.2008649](https://doi.org/10.1109/TPEL.2008.2008649).
- [144] F. Lin, Y. Huang, K. Tan, J. Chiu, and Y. Chang, "Active islanding detection method using D-axis disturbance signal injection with intelligent control," *IET Gener., Transmiss. Distrib.*, vol. 7, no. 5, pp. 537–550, May 2013, doi: [10.1049/iet-gtd.2012.0488](https://doi.org/10.1049/iet-gtd.2012.0488).
- [145] P. Gupta, R. S. Bhatia, and D. K. Jain, "Average absolute frequency deviation value based active islanding detection technique," *IEEE Trans. Smart Grid*, vol. 6, no. 1, pp. 26–35, Jan. 2015, doi: [10.1109/TSG.2014.2337751](https://doi.org/10.1109/TSG.2014.2337751).

- [146] X. Chen, Y. Li, and P. Crossley, "A novel hybrid islanding detection method for grid-connected microgrids with multiple inverter-based distributed generators based on adaptive reactive power disturbance and passive criteria," *IEEE Trans. Power Electron.*, vol. 34, no. 9, pp. 9342–9356, Sep. 2019, doi: [10.1109/TPEL.2018.2886930](https://doi.org/10.1109/TPEL.2018.2886930).
- [147] K. Naraghypour, I. Abdelsalam, K. H. Ahmed, and C. D. Booth, "Modified  $Q$ - $f$  droop curve method for islanding detection with zero non-detection zone," *IEEE Access*, vol. 9, pp. 158027–158040, 2021, doi: [10.1109/ACCESS.2021.3130370](https://doi.org/10.1109/ACCESS.2021.3130370).
- [148] J. Zhang, D. Xu, G. Shen, Y. Zhu, N. He, and J. Ma, "An improved islanding detection method for a grid-connected inverter with intermittent bilateral reactive power variation," *IEEE Trans. Power Electron.*, vol. 28, no. 1, pp. 268–278, Jan. 2013, doi: [10.1109/TPEL.2012.2196713](https://doi.org/10.1109/TPEL.2012.2196713).
- [149] Y. Zhu, D. Xu, N. He, J. Ma, J. Zhang, Y. Zhang, G. Shen, and C. Hu, "A novel RPV (reactive-power-variation) antiislanding method based on adapted reactive power perturbation," *IEEE Trans. Power Electron.*, vol. 28, no. 11, pp. 4998–5012, Nov. 2013, doi: [10.1109/TPEL.2013.2245512](https://doi.org/10.1109/TPEL.2013.2245512).
- [150] X. Chen and Y. Li, "An islanding detection method for inverter-based distributed generators based on the reactive power disturbance," *IEEE Trans. Power Electron.*, vol. 31, no. 5, pp. 3559–3574, May 2016, doi: [10.1109/TPEL.2015.2462333](https://doi.org/10.1109/TPEL.2015.2462333).
- [151] M. Ciobotaru, R. Teodorescu, and F. Blaabjerg, "A new single-phase PLL structure based on second order generalized integrator," in *Proc. 37th IEEE Power Electron. Spec. Conf.*, Jun. 2006, pp. 1–10, doi: [10.1109/PESC.2006.1711988](https://doi.org/10.1109/PESC.2006.1711988).
- [152] K. Jia, Z. Xuan, Y. Lin, H. Wei, and G. Li, "An islanding detection method for grid-connected photovoltaic power system based on AdaBoost algorithm," *Trans. China Electrotech. Soc.*, vol. 33, no. 5, pp. 1106–1113, 2018, doi: [10.19595/j.cnki.1000-6753.tces.170016](https://doi.org/10.19595/j.cnki.1000-6753.tces.170016).
- [153] W. Cai, B. Liu, S. Duan, and C. Zou, "An islanding detection method based on dual-frequency harmonic current injection under grid impedance unbalanced condition," *IEEE Trans. Ind. Informat.*, vol. 9, no. 2, pp. 1178–1187, May 2013, doi: [10.1109/TII.2012.2209669](https://doi.org/10.1109/TII.2012.2209669).
- [154] M. Tedde and K. Smedley, "Anti-islanding for three-phase one-cycle control grid tied inverter," *IEEE Trans. Power Electron.*, vol. 29, no. 7, pp. 3330–3345, Jul. 2014, doi: [10.1109/TPEL.2013.2278792](https://doi.org/10.1109/TPEL.2013.2278792).
- [155] S. Dhar and P. K. Dash, "Harmonic profile injection-based hybrid active islanding detection technique for PV-VSC-based microgrid system," *IEEE Trans. Sustain. Energy*, vol. 7, no. 4, pp. 1473–1481, Oct. 2016, doi: [10.1109/TSTE.2016.2515158](https://doi.org/10.1109/TSTE.2016.2515158).
- [156] M. Liu, W. Zhao, Q. Wang, S. Huang, and K. Shi, "Compatibility issues with irregular current injection islanding detection methods and a solution," *Energies*, vol. 12, no. 8, p. 1467, Apr. 2019, doi: [10.3390/en12081467](https://doi.org/10.3390/en12081467).
- [157] M. Liu, W. Zhao, Q. Wang, Z. Wang, C. Jiang, J. Shu, H. Wang, and Y. Bai, "Compatibility issues with irregular current injection islanding detection methods in multi-DG units equipped with grid-connected transformers," *IEEE Trans. Power Electron.*, vol. 37, no. 3, pp. 3599–3616, Mar. 2022, doi: [10.1109/TPEL.2021.3117879](https://doi.org/10.1109/TPEL.2021.3117879).
- [158] B.-G. Yu, M. Matsui, and G.-J. Yu, "A correlation-based islanding-detection method using current-magnitude disturbance for PV system," *IEEE Trans. Ind. Electron.*, vol. 58, no. 7, pp. 2935–2943, Jul. 2011, doi: [10.1109/TIE.2010.2080651](https://doi.org/10.1109/TIE.2010.2080651).
- [159] D. Voglitsis, N. P. Papanikolaou, and A. C. Kyritsis, "Active cross-correlation anti-islanding scheme for PV module-integrated converters in the prospect of high penetration levels and weak grid conditions," *IEEE Trans. Power Electron.*, vol. 34, no. 3, pp. 2258–2274, Mar. 2019, doi: [10.1109/TPEL.2018.2836663](https://doi.org/10.1109/TPEL.2018.2836663).
- [160] H. Karimi, A. Yazdani, and R. Iravani, "Negative-sequence current injection for fast islanding detection of a distributed resource unit," *IEEE Trans. Power Electron.*, vol. 23, no. 1, pp. 298–307, Jan. 2008, doi: [10.1109/TPEL.2007.911774](https://doi.org/10.1109/TPEL.2007.911774).
- [161] B. Bahrani, H. Karimi, and R. Iravani, "Nondetection zone assessment of an active islanding detection method and its experimental evaluation," *IEEE Trans. Power Del.*, vol. 26, no. 2, pp. 517–525, Apr. 2011, doi: [10.1109/TPWRD.2009.2036016](https://doi.org/10.1109/TPWRD.2009.2036016).
- [162] H. Y. Cao and Y. X. Tian, "An effective anti-islanding method for multi-inverter-based distributed generation," in *Proc. 2nd Int. Symp. Power Electron. Distrib. Gener. Syst.*, Feb. 2010, pp. 855–858, doi: [10.1109/PEDG.2010.5545874](https://doi.org/10.1109/PEDG.2010.5545874).
- [163] M. B. Shamsch, R. Inzunza, and T. Ambo, "A novel islanding detection technique based on positive-feedback negative sequence current injection," *IEEE Trans. Power Electron.*, vol. 37, no. 7, pp. 8611–8624, Jul. 2022, doi: [10.1109/TPEL.2022.3146342](https://doi.org/10.1109/TPEL.2022.3146342).
- [164] B.-H. Kim, S.-K. Sul, and C.-H. Lim, "Anti-islanding detection method using negative sequence voltage," in *Proc. 7th Int. Power Electron. Motion Control Conf.*, vol. 1, Jun. 2012, pp. 604–608, doi: [10.1109/IPEMCC.2012.6258814](https://doi.org/10.1109/IPEMCC.2012.6258814).
- [165] M. Alsharidah, N. A. Ahmed, and A. K. Alotthman, "Negative sequence injection for islanding detection of GRID interconnected distributed generators," in *Proc. IEEE Electr. Power Energy Conf.*, Nov. 2014, pp. 267–274, doi: [10.1109/EPEC.2014.38](https://doi.org/10.1109/EPEC.2014.38).
- [166] D.-U. Kim and S. Kim, "Anti-islanding detection method using phase-shifted feed-forward voltage in grid-connected inverter," *IEEE Access*, vol. 7, pp. 147179–147190, 2019, doi: [10.1109/ACCESS.2019.2946317](https://doi.org/10.1109/ACCESS.2019.2946317).
- [167] J. Muñoz-Cruzado-Alba, J. Villegas-Núñez, J. A. Vite-Frías, J. M. Carrasco-Solis, and E. Galván-Díez, "New low-distortion  $Q$ - $f$  droop plus correlation anti-islanding detection method for power converters in distributed generation systems," *IEEE Trans. Ind. Electron.*, vol. 62, no. 8, pp. 5072–5081, Aug. 2015, doi: [10.1109/TIE.2015.2405894](https://doi.org/10.1109/TIE.2015.2405894).
- [168] T. Matsuzaki, "Development of the (A frequency feedback method with step reactive power injection)," SANYO DENKIT, Tokyo, Japan, Tech. Rep. 43, 2017.
- [169] K. Gottapu, T. R. Jyothsna, and V. V. S. N. Yirrinki, "Performance of a new hybrid approach for detection of islanding for inverter-based DGs," *Renew. Energy Focus*, vol. 43, pp. 1–10, Dec. 2022, doi: [10.1016/j.ref.2022.08.001](https://doi.org/10.1016/j.ref.2022.08.001).
- [170] S. Akhlaghi, M. Sarailoo, A. Akhlaghi, and A. A. Ghadimi, "A novel hybrid approach using sms and ROCOF for islanding detection of inverter-based DGs," in *Proc. IEEE Power Energy Conf. at Illinois (PECI)*, Feb. 2017, pp. 1–7, doi: [10.1109/PECI.2017.7935746](https://doi.org/10.1109/PECI.2017.7935746).
- [171] F. Barkat, A. Cheknane, J. M. Guerrero, A. Lashab, M. Istrate, and I. Viorel Banu, "Hybrid islanding detection technique for single-phase grid-connected photovoltaic multi-inverter systems," *IET Renew. Power Gener.*, vol. 14, no. 18, pp. 3864–3880, Dec. 2020, doi: [10.1049/iet-rpg.2019.1183](https://doi.org/10.1049/iet-rpg.2019.1183).
- [172] S.-K. Wang and C.-C. Lien, "Development of hybrid ROCOF and RPV method for anti-islanding protection," *J. Chin. Inst. Eng.*, vol. 42, no. 7, pp. 613–626, Oct. 2019, doi: [10.1080/02533839.2019.1638308](https://doi.org/10.1080/02533839.2019.1638308).
- [173] C. Rami Reddy, K. Harinadha Reddy, F. Aymen, B. Srikanth Goud, M. Bajaj, M. J. Abdulaal, and A. H. Miliyani, "Hybrid ROCOF relay for islanding detection," *J. Electr. Eng. Technol.*, vol. 17, no. 1, pp. 51–60, Jan. 2022, doi: [10.1007/s42835-021-00856-9](https://doi.org/10.1007/s42835-021-00856-9).
- [174] L. Rokach and O. Maimon, "Top-down induction of decision trees classifiers—A survey," *IEEE Trans. Syst., Man Cybern., C, Appl. Rev.*, vol. 35, no. 4, pp. 476–487, Nov. 2005, doi: [10.1109/TSMCC.2004.843247](https://doi.org/10.1109/TSMCC.2004.843247).
- [175] N. W. A. Lidula and A. D. Rajapakse, "A pattern-recognition approach for detecting power islands using transient signals—Part II: Performance evaluation," *IEEE Trans. Power Del.*, vol. 27, no. 3, pp. 1071–1080, Jul. 2012, doi: [10.1109/TPWRD.2012.2187344](https://doi.org/10.1109/TPWRD.2012.2187344).
- [176] M. Heidari, G. Seifossadat, and M. Razaz, "Application of decision tree and discrete wavelet transform for an optimized intelligent-based islanding detection method in distributed systems with distributed generations," *Renew. Sustain. Energy Rev.*, vol. 27, pp. 525–532, Nov. 2013, doi: [10.1016/j.rser.2013.06.047](https://doi.org/10.1016/j.rser.2013.06.047).
- [177] A. M. Sawas, W. L. Woon, R. Pandi, M. Shaaban, and H. Zeineldin, "A multistage passive islanding detection method for synchronous-based distributed generation," *IEEE Trans. Ind. Informat.*, vol. 18, no. 3, pp. 2078–2088, Mar. 2022, doi: [10.1109/TII.2021.3065015](https://doi.org/10.1109/TII.2021.3065015).
- [178] N. B. Hartmann, R. C. dos Santos, A. P. Grilo, and J. C. M. Vieira, "Hardware implementation and real-time evaluation of an ANN-based algorithm for anti-islanding protection of distributed generators," *IEEE Trans. Ind. Electron.*, vol. 65, no. 6, pp. 5051–5059, Jun. 2018, doi: [10.1109/TIE.2017.2767524](https://doi.org/10.1109/TIE.2017.2767524).
- [179] S. Admasie, S. B. A. Bukhari, T. Gush, R. Haider, and C. H. Kim, "Intelligent islanding detection of multi-distributed generation using artificial neural network based on intrinsic mode function feature," *J. Mod. Power Syst. Clean Energy*, vol. 8, no. 3, pp. 511–520, 2020, doi: [10.35833/mpce.2019.000255](https://doi.org/10.35833/mpce.2019.000255).
- [180] A. Khamis, Y. Xu, Z. Y. Dong, and R. Zhang, "Faster detection of microgrid islanding events using an adaptive ensemble classifier," *IEEE Trans. Smart Grid*, vol. 9, no. 3, pp. 1889–1899, May 2018, doi: [10.1109/TSG.2016.2601656](https://doi.org/10.1109/TSG.2016.2601656).
- [181] M. Mishra, M. Sahani, and P. K. Rout, "An islanding detection algorithm for distributed generation based on Hilbert–Huang transform and extreme learning machine," *Sustain. Energy, Grids Netw.*, vol. 9, pp. 13–26, Mar. 2017, doi: [10.1016/j.segan.2016.11.002](https://doi.org/10.1016/j.segan.2016.11.002).

[182] M. Mishra and P. K. Rout, "Loss of main detection in distribution generation system based on hybrid signal processing and machine learning technique," *Int. Trans. Electr. Energy Syst.*, vol. 29, no. 1, p. e2676, Jan. 2019, doi: [10.1002/etep.2676](https://doi.org/10.1002/etep.2676).

[183] S. A. Kumar, M. S. P. Subathra, N. M. Kumar, M. Malvoni, N. J. Sairamya, S. T. George, E. S. Suvishamuthu, and S. S. Chopra, "A novel islanding detection technique for a resilient photovoltaic-based distributed power generation system using a tunable-Q wavelet transform and an artificial neural network," *Energies*, vol. 13, no. 16, p. 4238, Aug. 2020, doi: [10.3390/en13164238](https://doi.org/10.3390/en13164238).

[184] M. R. Alam, K. M. Muttaqi, and A. Bouzerdoum, "An approach for assessing the effectiveness of multiple-feature-based SVM method for islanding detection of distributed generation," *IEEE Trans. Ind. Appl.*, vol. 50, no. 4, pp. 2844–2852, Jul. 2014, doi: [10.1109/TIA.2014.2300135](https://doi.org/10.1109/TIA.2014.2300135).

[185] M. R. Alam, K. M. Muttaqi, and A. Bouzerdoum, "A multifeature-based approach for islanding detection of DG in the subcritical region of vector surge relays," *IEEE Trans. Power Del.*, vol. 29, no. 5, pp. 2349–2358, Oct. 2014, doi: [10.1109/TPWRD.2014.2315839](https://doi.org/10.1109/TPWRD.2014.2315839).

[186] H. R. Baghaee, D. Mlakic, S. Nikolovski, and T. Dragicevic, "Support vector machine-based islanding and grid fault detection in active distribution networks," *IEEE J. Emerg. Sel. Topics Power Electron.*, vol. 8, no. 3, pp. 2385–2403, Sep. 2020, doi: [10.1109/JESTPE.2019.2916621](https://doi.org/10.1109/JESTPE.2019.2916621).

[187] N. Gupta, H. Singh, and J. Singla, "Fuzzy logic-based systems for medical diagnosis—A review," in *Proc. 3rd Int. Conf. Electron. Sustain. Commun. Syst. (ICESC)*, Aug. 2022, pp. 1058–1062, doi: [10.1109/ICESC54411.2022.9885338](https://doi.org/10.1109/ICESC54411.2022.9885338).

[188] S. R. Samantary, K. El-Arroudi, G. Joós, and I. Kamwa, "A fuzzy rule-based approach for islanding detection in distributed generation," *IEEE Trans. Power Del.*, vol. 25, no. 3, pp. 1427–1433, Jul. 2010, doi: [10.1109/TPWRD.2010.2042625](https://doi.org/10.1109/TPWRD.2010.2042625).

[189] J.-S.-R. Jang, "ANFIS: Adaptive-network-based fuzzy inference system," *IEEE Trans. Syst., Man, Cybern.*, vol. 23, no. 3, pp. 665–685, Mar. 1993, doi: [10.1109/21.256541](https://doi.org/10.1109/21.256541).

[190] N. Ghadimi and B. Sobhani, "Adaptive neuro-fuzzy inference system (ANFIS) islanding detection based on wind turbine simulator," *Int. J. Phys. Sci.*, vol. 8, no. 27, pp. 1424–1436, 2013.

[191] N. Ghadimi, "An adaptive neuro-fuzzy inference system for islanding detection in wind turbine as distributed generation," *Complexity*, vol. 21, no. 1, pp. 10–20, Sep. 2015, doi: [10.1002/cplx.21537](https://doi.org/10.1002/cplx.21537).

[192] W. J. Zhang, G. Yang, Y. Lin, C. Ji, and M. M. Gupta, "On definition of deep learning," in *Proc. World Autom. Congr.*, Jun. 2018, pp. 232–236, doi: [10.23919/WAC.2018.8430387](https://doi.org/10.23919/WAC.2018.8430387).

[193] X. Kong, X. Xu, Z. Yan, S. Chen, H. Yang, and D. Han, "Deep learning hybrid method for islanding detection in distributed generation," *Appl. Energy*, vol. 210, pp. 776–785, Jan. 2018, doi: [10.1016/j.apenergy.2017.08.014](https://doi.org/10.1016/j.apenergy.2017.08.014).

[194] Y. Sheng, "Wavelet transform," in *Fundamentals of Image Data Mining*. New York, NY, USA: Springer, 2010, pp. 10-1–10-54, doi: [10.1201/9781420066531](https://doi.org/10.1201/9781420066531).

[195] A. Pigazo, M. Liserre, R. A. Mastromauro, V. M. Moreno, and A. Dell'Aquila, "Wavelet-based islanding detection in grid-connected PV systems," *IEEE Trans. Ind. Electron.*, vol. 56, no. 11, pp. 4445–4455, Nov. 2009, doi: [10.1109/TIE.2008.928097](https://doi.org/10.1109/TIE.2008.928097).

[196] A. Samui and S. R. Samantary, "Wavelet singular entropy-based islanding detection in distributed generation," *IEEE Trans. Power Del.*, vol. 28, no. 1, pp. 411–418, Jan. 2013, doi: [10.1109/TPWRD.2012.2220987](https://doi.org/10.1109/TPWRD.2012.2220987).

[197] S. A. Saleh, A. S. Aljankawey, R. Meng, J. Meng, C. P. Diduch, and L. Chang, "Antiislanding protection based on signatures extracted from the instantaneous apparent power," *IEEE Trans. Power Electron.*, vol. 29, no. 11, pp. 5872–5891, Nov. 2014, doi: [10.1109/TPEL.2013.2296113](https://doi.org/10.1109/TPEL.2013.2296113).

[198] T. Deepika, "Analysis and comparison of different wavelet transform methods using benchmarks for image fusion," 2020, *arXiv:2007.11488*.

[199] S. A. Saleh, A. S. Aljankawey, R. Meng, J. Meng, L. Chang, and C. P. Diduch, "Apparent power-based anti-islanding protection for distributed cogeneration systems," *IEEE Trans. Ind. Appl.*, vol. 52, no. 1, pp. 83–98, Jan. 2016, doi: [10.1109/TIA.2015.2464307](https://doi.org/10.1109/TIA.2015.2464307).

[200] S. A. Saleh, E. Ozkop, and A. S. Aljankawey, "The development of a coordinated anti-islanding protection for collector systems with multiple distributed generation units," *IEEE Trans. Ind. Appl.*, vol. 52, no. 6, pp. 4656–4667, Nov. 2016, doi: [10.1109/TIA.2016.2594231](https://doi.org/10.1109/TIA.2016.2594231).

[201] S. C. Paiva, R. L. D. A. Ribeiro, D. K. Alves, F. B. Costa, and T. D. O. A. Rocha, "A wavelet-based hybrid islanding detection system applied for distributed generators interconnected to AC microgrids," *Int. J. Electr. Power Energy Syst.*, vol. 121, Oct. 2020, Art. no. 106032, doi: [10.1016/j.ijepes.2020.106032](https://doi.org/10.1016/j.ijepes.2020.106032).

[202] M. A. Farhan and K. Shanti Swarup, "Mathematical morphology-based islanding detection for distributed generation," *IET Gener., Transmiss. Distrib.*, vol. 10, no. 2, pp. 518–525, Feb. 2016, doi: [10.1049/iet-gtd.2015.0910](https://doi.org/10.1049/iet-gtd.2015.0910).

[203] F. Ghalavand, B. Alizade, H. Gaber, and H. Karimipour, "Micro-grid islanding detection based on mathematical morphology," *Energies*, vol. 11, no. 10, p. 2696, Oct. 2018, doi: [10.3390/en11102696](https://doi.org/10.3390/en11102696).

[204] B. K. Chaitanya, A. Yadav, M. Pazoki, and A. Y. Abdelaziz, *A Comprehensive Review of Islanding Detection Methods*. Amsterdam, The Netherlands: Elsevier, 2021, doi: [10.1016/b978-0-12-820491-7.00008-6](https://doi.org/10.1016/b978-0-12-820491-7.00008-6).

[205] R. Kaushik, O. P. Mahela, P. K. Bhatt, B. Khan, A. R. Garg, H. H. Alhelou, and P. Siano, "Recognition of islanding and operational events in power system with renewable energy penetration using a stockwell transform-based method," *IEEE Syst. J.*, vol. 16, no. 1, pp. 166–175, Mar. 2022, doi: [10.1109/JSYST.2020.3020919](https://doi.org/10.1109/JSYST.2020.3020919).

[206] B. K. Chaitanya and A. Yadav, "Hilbert–Huang transform based islanding detection scheme for distributed generation," in *Proc. 8th IEEE Power India Int. Conf. (PIICON)*, Feb. 2018, pp. 1–5.

[207] P. P. Mishra and C. N. Bhende, "Islanding detection based on variational mode decomposition for inverter based distributed generation systems," *IFAC-PapersOnLine*, vol. 52, no. 4, pp. 306–311, 2019, doi: [10.1016/j.ifacol.2019.08.216](https://doi.org/10.1016/j.ifacol.2019.08.216).

[208] S. Salimi and A. Koochaki, "An effective method for islanding detection based on variational mode decomposition," *Electrica*, vol. 19, no. 2, pp. 135–145, Jul. 2019, doi: [10.26650/electrica.2019.19007](https://doi.org/10.26650/electrica.2019.19007).

[209] L. Jaulin, "Kalman filter," in *Mobile Robotics*. Amsterdam, The Netherlands: Elsevier, 2015, pp. 219–294, doi: [10.1016/B978-1-78548-048-5.50007-3](https://doi.org/10.1016/B978-1-78548-048-5.50007-3).

[210] D. Coln and M. S. de Padua, "Kalman filter on power electronics and power systems applications," in *Kalman Filter: Recent Advances and Applications*. London, U.K.: IntechOpen, Apr. 2009, doi: [10.5772/6815](https://doi.org/10.5772/6815).

[211] A. T. Kolli and N. Ghaffarzadeh, "A novel phaselet-based approach for islanding detection in inverter-based distributed generation systems," *Electr. Power Syst. Res.*, vol. 182, May 2020, Art. no. 106226, doi: [10.1016/j.epr.2020.106226](https://doi.org/10.1016/j.epr.2020.106226).

[212] A. Kumar, B. R. Kumar, R. K. Panda, A. Mohapatra, and S. N. Singh, "Phaselet approach for islanding detection in active distribution networks," in *Proc. IEEE Power Energy Soc. Gen. Meeting (PESGM)*, Aug. 2019, pp. 1–5, doi: [10.1109/PESGM40551.2019.8973438](https://doi.org/10.1109/PESGM40551.2019.8973438).

[213] M. Khamis, T. Shareef, and H. Wanik, "Pattern recognition of islanding detection using Tt-transform," *J. Asian Sci. Res.*, vol. 2, no. 11, pp. 607–613, 2012. [Online]. Available: <https://archive.aessweb.com/index.php/5003/article/view/3402>

[214] A. A. Arefin, M. Baba, N. S. S. Singh, N. B. M. Nor, M. A. Sheikh, R. Kannan, G. E. M. Abro, and N. Mathur, "Review of the techniques of the data analytics and islanding detection of distribution systems using phasor measurement unit data," *Electronics*, vol. 11, no. 18, p. 2967, Sep. 2022, doi: [10.3390/electronics11182967](https://doi.org/10.3390/electronics11182967).



**ÊNIO COSTA RESENDE** received the bachelor's degree in electrical engineering from the Federal University of Uberlândia (UFU), Brazil, with an exchange period through the CsF/CAPES Program, Sacramento State University (SAC-State), Sacramento, CA, USA, in 2018, and the M.Sc. degree in electrical engineering with the specialization in power electronics from the Power Electronics Research Center (NUPEP), UFU Postgraduate Program, in 2020, where he is currently pursuing the Ph.D. degree in electrical engineering. During the master's degree, he studied and developed islanding detection techniques, synchronization strategies, and MPPT methods. His research interests include islanding detection, distributed generation, renewable energies, MPPT, control methods, and power quality.

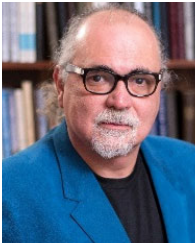

**MARCELO GODOY SIMÕES** (Fellow, IEEE) received the B.Sc. and M.Sc. degrees from the University of São Paulo, Brazil, in 1985 and 1990, respectively, the Ph.D. degree from The University of Tennessee, Knoxville, TN, USA, in 1995, the D.Sc. degree (Livre-Docência) from the University of São Paulo, in 1998. From 2014 to 2015, he was a U.S. Fulbright Fellow with the Institute of Energy Technology, Aalborg University, Denmark. He is a pioneer in applying neural networks and fuzzy logic in power electronics, motor drives, and renewable energy systems.

His fuzzy logic-based modeling and control for wind turbine optimization is used as a basis for advanced wind turbine control and it has been cited worldwide. His leadership in modeling fuel cells is internationally and highly influential in providing a basis for further developments in fuel cell automation control in many engineering applications. He made substantial and lasting contributions to artificial intelligence technology in many applications, power electronics, motor drives, and fuzzy control of wind generation systems, such as fuzzy logic-based waveform estimation for power quality, neural network-based estimation for vector-controlled motor drives, and the integration of alternative energy systems to the electric grid through AI modeling-based power electronics control. His current research interests include power electronics, power systems, power quality, smart grids, and renewable energy systems. He was elevated to the grade of IEEE Fellow, with the citation: “for applications of artificial intelligence in control of power electronics systems.”



**LUIZ CARLOS GOMES FREITAS** was born in Uberlândia, Brazil, in 1976. He received the bachelor's degree in electrical engineering with an emphasis on power systems and the master's and Ph.D. degrees in electrical engineering with an emphasis on power electronics from the Federal University of Uberlândia (UFU), in 2001, 2003, and 2006, respectively. In the Ph.D. thesis, he developed an innovative topological design of a three-phase hybrid rectifier for high-power drive systems.

In 2008, he joined as a Faculty Member of UFU, where he is developing teaching and research activities in the area of power electronics and power systems. Since 2010, he has been a Coordinator with the Power Electronics Research Center (NUPEP), UFU. Since 2013, he has also been a Researcher recognized by the National Council for Scientific and Technological Development (CNPq) with a Research Productivity Grant. His research interests include electrical engineering, conversion, and rectification of electric energy, working on various topics related to power electronics, electric power quality, and renewable energy. In 2012, he received the Second Prize Paper Award of the IEEE-IAS-Industrial Automation and Control Committee (IACC) for his contribution to the development of hybrid rectifier structures.

• • •