

An Efficient Rapid Method for Generators Coherency Identification in Large Power Systems

ALIREZA MEHRZAD¹, MILAD DARMIANI¹,
YASHAR MOUSAVI² (Graduate Student Member, IEEE),
MIADREZA SHAFIE-KHAH³ (Senior Member, IEEE),
AND MOHAMMADREZA AGHAMOHAMMADI⁴

¹Department of Electrical Engineering, University of Birjand, Birjand 97174-34765, Iran

²Department of Applied Science, School of Computing, Engineering and Built Environment, Glasgow Caledonian University, Glasgow G4 0BA, U.K.

³School of Technology and Innovations, University of Vaasa, 65200 Vaasa, Finland

⁴Electrical Engineering Faculty, Shahid Beheshti University, Tehran 19839-69411, Iran

CORRESPONDING AUTHOR: M. SHAFIE-KHAH (mshafiek@univaasa.fi)

ABSTRACT With steadily increasing interest in enhancing large power systems' transient stability, generator coherency identification has become critical for the dynamic equivalents, controlled-islanding, and wide-area control of these systems. This paper presents an approach based on two classical and powerful techniques. The proposed method comprises the slow coherency method followed by the time-domain-based simulation of transient stability to identify the coherent groups of generators. In this regard, various operating conditions of the system are considered to obtain the updated coherency information between groups of generators by analyzing the chosen generator rotor angle. The proposed approach's merits are tested on the New England IEEE 39-Bus and modified IEEE 118-Bus test systems in the PowerFactory software tools through Python. Corresponding simulation results validate the proposed paradigm's effectiveness by enhancing the transient stability speed of a large power system without decreasing its coherency behavior accuracy. It is also observed that the proposed scheme tends to be more consistent in determining the coherent groups of generators in the presence of disturbances and different operational conditions.

INDEX TERMS Coherent groups, generator coherency, slow coherency, transient stability.

NOMENCLATURES

DMD	Dynamic mode decomposition.
PMU	Phasor measurement units.
RMS/EMT	Electromagnetic transient/root mean square.
SCC	Spearman correlation coefficient.
TSA	Transient stability analysis.
CC_{ij}	The SCC between generator rotor angles.
CC_{ave}	Average CC .
$\delta_{i,j}$	Rotor angles.
$d\delta_{i,j}$	Ranks of rotor angles.
$\Delta\delta$	Angle deviation.
n	Number of sample points.
b	Slope parameter.
b_{ave}	Average slope parameter.
ϵ	Error term.

M	Machine inertia.
V	Machine terminal bus voltage.
ΔV	Machine voltage deviation.
f	Acceleration torque.
g	Power flow.
A	Synchronizing torque coefficient.
E_i	Internal voltage of generator i .
G_{ij}, B_{ij}	Real and imaginary admittance between machines i and j .
r	Number of groups.

I. INTRODUCTION

MOTIVATED by the increasing energy demands, the interconnected power systems have grown extensively, forcing large power systems to operate very close

to stability limits under the deregulated business environment, and thus more vulnerable under disturbances [1]. Interconnection of power plants, weak tie-lines, system failures, unexpected events, and human errors may cause increasing electromechanical oscillations in the form of local and inter-area oscillations between interconnected generators, which approximately have a frequency range of 0.1-2 Hz [2]. Large disturbances lead to oscillations in the generators located in an electrical area. Observations on the oscillations frequency have revealed that some generators demonstrate similar responses to the disturbance, as they tend to swing together coherently at the same frequency and close angles. Accordingly, they are called coherent generators [3].

In a power system, transient stability and dynamic responses are essential issues, which bold coherent generators' identification. Several studies in the literature have been devoted to direct applications [4]–[8]. Authors in [5], [6] utilized the dynamic model reduction to reduce the computation complexity in large scale power systems. They divided the power system into the external area and the study area. The former comprised a group of coherent generators lumped together to reduce the system's order, while the latter was without alternation. The controlled-islanding was performed in [7], [8] to prevent the cascading outages caused by large disturbance, where systems were partitioned to controlled islands by diverse constraints after identifying coherent groups. Another application is the wide-area control [9], [10], which has effective damping for inter-area critical modes oscillations by use of coherency identification and employing phasor measurement units (PMU) for selection of wide-area signals [11].

The coherent generators groups identifications methods can be categorized as model-based and measurement-based approaches. The first category requires a linear/nonlinear simulation in the time domain [12]. Despite the faster response of the linear time simulation with respect to the nonlinear simulation [9], they cannot always guarantee the desired efficiency in dealing with nonlinear power systems under large disturbance [13], [14]. In addition, although the linear time simulation can provide a high computing efficiency in dealing with the linearized model of power systems, the achieved accuracy strongly depends on the network structure and the parameters of the concerned power system. Authors in [15] used relation factor, representing the relative coupling degree between the generators, while in [16], the authors developed an extended Krylov subspace technique-based balanced truncation approach for dynamic model reduction and coherency identification of large-scale power systems. Another model-based method that has been extensively used in dynamic equivalents is slow coherency based on the two-time scale theory [1], [11], [17]. The coherent groups of generators can be found by time-scale separation of the inter-area modes and local modes and implementing eigenvector-based algorithms. On the other hand, the second category employs PMUs to identify coherent groups. In this regard, authors in [18] determined the coherent groups

of generators by dynamic frequency deviations to the system nominal frequency, while [19] used Fourier transform analysis, and [20] utilized dynamic mode decomposition (DMD).

Despite all advantages enclosed in the aforementioned approaches, there are some gaps to be fulfilled. The main limitation of the model-based methods is associated with the inter-area oscillation, such that they have been proved inefficient when the inter-area oscillation is not sufficiently reduced [14]. Due to the linearization of the system in the above-mentioned classic synchronous generator models, less accuracy of coherent groups of generators is achieved when the system operating condition and large load step network configuration is changed. Furthermore, the measurement-based methods are sensitive to spurious signal components, and due to their disturbance-dependency, their results have been found unreliable during changing system conditions [5]. Table 1 presents a comparative study of the recent literature with the current work in terms of model type, disturbance dependency, identification method, and operating conditions. It is worthwhile to mention that selecting a model-based or measurement-based technique entirely depends on the application. In this respect, if the goal is to construct reduced order equivalents to facilitate transient stability analysis [15], [16] or design a control scheme for inter-area oscillations mitigation [17], model-based coherency identification approaches have to be employed. However, considering [15]–[17] in Table 1 it can be observed that the linear model of the system is used, where the details of generator models are neglected, inferring that the impacts of generator controllers on coherency are not considered. In addition, the systems are linearized around an operating point that depends on the system's operating conditions. Hence, any change in the operating point due to a change of topology or short-term large load changes can cause the linearization to be invalid. On the contrary, the employment of the measurement-based methods is required when applications such as event location [13], [18], [20] or controlled islanding by considering local excited modes are of interest. However, the processing of on-line measurement-based methods poses several challenges and limitations related to the data-collection infrastructure, excessive computational burden, and bandwidth requirements that affect coherency grouping's success. Accordingly, the designer has to consider the probability of losing data when dealing with PMUs, which can arise due to PMU or communication media loss. Furthermore, the measured signals can be affected by noise which degrades the reliability of the data. Moreover, with respect to inherit characteristics of coherency identification approaches, generators' grouping identification modes can be classified into direct and indirect classes as illustrated in Table 1. The former obtains the generators' grouping directly from the coherency identification results, and no additional clustering algorithm is used to determine the coherent groups (such as the proposed method and [14]–[17], [20]). On the other hand, in the indirect class [1], [13], [18], the degree of coherency between generators is calculated, and then algorithms such

as fuzzy C-means, support vector clustering, artificial neural networks, etc., are used to group the generators.

In accordance with the above-discussed literature, this paper aims to analyze the coherency behavior between the coherent groups of large-scale power systems considering varying inter-area modes under disturbances and different operating conditions. To the best of the authors' knowledge, the proposed method has not been addressed in the existing literature. This study contributes the literature as follows:

- A coherency method based on slow coherency and transient stability is developed to deal with the coherency identification problem. Accordingly, the generator slow coherency is used to obtain necessary coherency information, and the largest generators in terms of nominal power in each group are selected as the reference generators.
- The rotor angle oscillations of reference generators are obtained by employing the nonlinear transient stability analysis (TSA) in the disturbed system. Furthermore, to deal with one of the main deficiencies of previous methods, the computational complexity of nonlinear TSA is reduced using the ward equivalent technique.
- A two-step clustering algorithm evaluates the swing curves obtained from the reference generators. The algorithm comprises the Spearman correlation and linear regression, which reduces the correlation coefficients' weaknesses in some cases and provides high accuracy in reference generators' grouping.
- The developed approach uses the curve-fitting method to eliminate the small oscillations in the rotor angle to diminish the probable errors in the linear regression parameters.

The rest of the paper is organized as follows. Section II describes the generator slow coherency. Section III presents the procedure of using ward reduction properties to reduce generators' number for transient stability implementation. In Section IV, the proposed approach is validated by implementation on IEEE 118-bus test system; and finally, conclusion and discussions are provided in Section V.

II. SLOW COHERENCY AS THE FIRST STAGE

A. PRELIMINARIES

As the main core of statistical analysis, two indexes are utilized to identify the coherency between rotor angles data of reference generators.

1) SPEARMAN CORRELATION COEFFICIENT

Spearman correlation coefficient (SCC) measures the strength of a monotonic relationship between paired data and can capture nonlinear association, with no sensitivity to the paired data values. In this case, the correlation coefficients of rotor angle oscillations are employed to evaluate the coherency degree between two reference generators

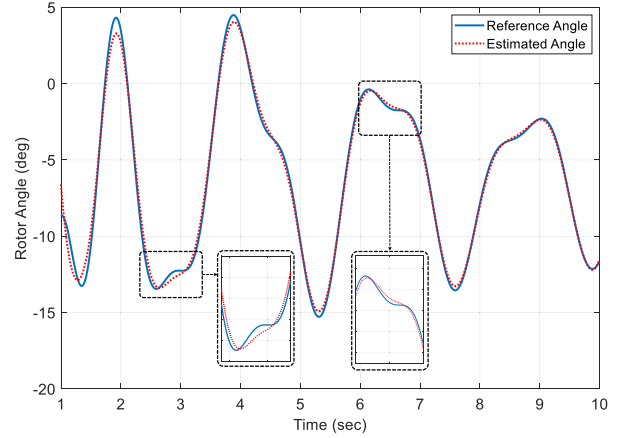

FIGURE 1. Curve-fitting-based estimation of the generator rotor angle.

(e.g. i, j) [21]:

$$CC_{ij} = 1 - \left(\frac{6 \sum d^2}{n(n^2 - 1)} \right), \quad (1)$$

where $-1 \leq CC_{ij} \leq 1$ is the SCC between generator rotor angles i and j , n denotes the number of sample points in the time interval, $d = d_{\delta_i} - d_{\delta_j}$ and d_{δ_i} and d_{δ_j} are the ranks of rotor angles δ_i and δ_j , respectively. It is worth noting that $CC_{ij} = 1$ demonstrates the strong relationship between two rotor angles [22]. One of the main deficiencies of correlation coefficient method is lack of precision in some cases [21].

2) SIMPLE LINEAR REGRESSION

The regression methods determine the relationship between a dependent variable Y_i with one or more independent variables X_i [23]. The line slope in a simple linear regression model shows the dependent variable's sensitivity value to the independent variable.

$$Y_i = bX_i + \epsilon_i, \quad (2)$$

where b is the slope parameter and ϵ denotes the error term.

Remark 1: The linear regression algorithm applied in this work considers the occurrence time of maximum points as the index. Hence, even the most minor oscillations can result in performance degradation. Accordingly, a curve-fitting technique is used to choose the main peaks' occurrence time and retain the results being affected by small oscillations. Figure 1 shows the generator rotor angle and its curve-fitting-based estimation, where the insets show the detail of the regions highlighted by dashed black lines.

In this study, b is used to evaluate the relationship between the maximum points of two rotor angles curve over a specified time window. Accordingly, closer values to 1 indicate a stronger connection between the two swing curves' maximum points, meaning the same-time occurrence of the maximum points. Furthermore, linear regression successfully

TABLE 1. Features comparison of some coherency identification methods.

Method (Ref.)	Model type	Disturbance dependent	Model-based	Measurement-based	On-line	Off-line	Applicable in faulty condition	Identification type
[1]	Nonlinear	Yes	-	*	*	-	*	Indirect
[13]	Nonlinear	Yes	-	*	*	-	*	Indirect
[14]	Nonlinear	Yes	-	*	*	-	*	Direct
[15]	Linearized	Yes	*	-	-	*	-	Direct
[16]	Linearized	Yes	*	-	-	*	-	Direct
[17]	Linearized	No	*	-	-	*	-	Direct
[18]	Nonlinear	Yes	-	*	*	-	*	Indirect
[20]	Nonlinear	Yes	-	*	*	-	-	Direct
Proposed	Nonlinear	Yes	*	-	-	*	*	Direct

overcomes the lack of precision associated with the correlation coefficient method.

B. SLOW COHERENCY

The slow modes that reflect the coherent groups' motions relative to each other are denoted as inter-area modes. Accordingly, if slow inter-area modes are excited, the generator angles in each area correlate coherently with each other. Generator slow coherency is valid for both linear and nonlinear power system electromechanical models [11]. The excitation and governor systems only affect the transients' damping, but not the natural frequencies and mode shapes [24]. Neglecting the damping, the linearized electromechanical model can be expressed as follows [25],

$$M \Delta \ddot{\delta} = A \Delta \delta, \quad (3)$$

where M denotes the diagonal machine inertia matrix, δ is the machine rotor angle vector, and A is the synchronizing torque coefficient matrix expressed as

$$A_{ij} = E_i E_j (B_{ij} \cos(\delta_i - \delta_j) - G_{ij} \sin(\delta_i - \delta_j))|_{\delta_0, V_0}, i \neq j, \quad (4)$$

$$A_{ii} = - \sum_{j=1, i \neq j}^n A_{ij}, \quad (5)$$

where E_i denotes the internal voltage of the generator i , G_{ij} and B_{ij} are the real and imaginary parts of equivalent admittance between machine i and j , and can be achieved through [25].

Considering the system state space matrix $M^{-1}A$, the generator slow coherency can be identified [7]. The initial coherent groups are identified so far. The next section is devoted to the groups' coherency behavior analysis in different conditions with TSA.

III. EXTENDED WARD REDUCTION AND COHERENCY

Transient stability analysis on large scale power systems has been found to be a computationally challenging task to fulfill [6], [11]. Computation effort can be diminished by reducing the swing equations of the power system. In this regard, in each group, the largest generator in terms of nominal power is selected as the reference, and other generators are converted to their equivalent AC voltage source via the extended ward reduction method [26], [27]. Authors in [26]

initially developed the extended ward in order to use the VAR model to increase accuracy in active and reactive power flows; however, the ward equivalent has been widely used in industry for the reduction of generators and loads that are located at the border bus [27].

Remark 2: In this paper, the generators' reduction is carried out using extended ward reduction for the non-reference generators. Despite the dynamic equivalent methods that reduce the number of lines and buses during the calculations, benefiting from the equivalent ward, the proposed paradigm converts the predetermined non-reference generators to their equivalent ward model without affecting the natural frequency. Accordingly, the non-reference generators remain unchanged and are retained from being added to transient stability calculations. Consequently, only the reference generators of each group are being compared, which leads to decreased overall computational complexity.

Remark 3: In both slow coherency and TSA methods, if generator i is coherent with generator j , and generators j and k are coherent, generator i and k are also coherent [11].

According to Remark 3, a generator with the most power can be selected as the group's representative to investigate the coherency behavior between groups [3]. A critical principle in the coherency is that the level of detail in the generator model only affects the damping of transients, and the swing curves' natural frequencies remain unchanged [24]. The natural frequency is relatively devoid of transients and other frequencies [28]; consequently, converting some generators to an equivalent AC voltage source does not affect the remaining generators' natural frequencies. To determine the coherency using the indexes mentioned in the previous section, the values obtained for each index must be greater than its average value. Besides, the negative and repetitive numbers must be eliminated to obtain the average values. The average value of correlation coefficients and simple linear regression of all generator pairs can be expressed as follows:

$$CC_{ave} = \frac{1}{N} \sum_i^N \sum_j^N CC_{ij}, \quad i \neq j, \quad (6)$$

$$b_{ave} = \frac{1}{N} \sum_i^N \sum_j^N b_{ij}, \quad i \neq j. \quad (7)$$

Accordingly, if the values of both generator pairs i and j are larger than their average values (CC_{ave} , b_{ave}), the two

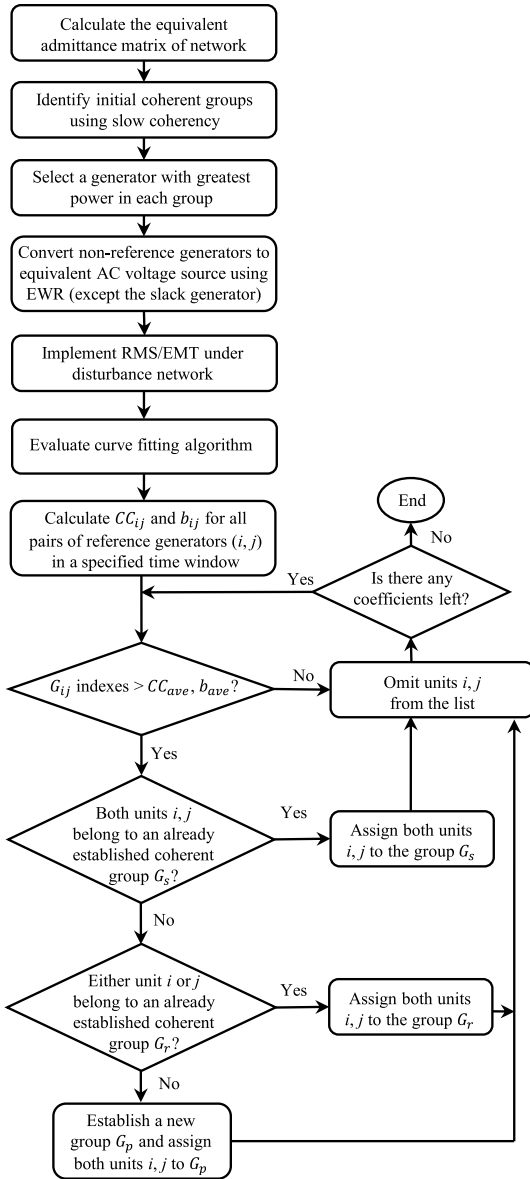

FIGURE 2. Flowchart of proposed method for identification coherent groups.

generators are coherent for a particular fault. For large power systems, the r smallest eigenvalues and their corresponding eigenvectors of A can be calculated according to the sparsity-based Arnoldi method [11]. The initial slow coherent group is updated by the group obtained from CC_{ij} and b_{ij} indexes. Figure 2 depicts the proposed method's flowchart to identify the coherent groups between selected reference generators by slow coherency.

IV. SIMULATIONS AND VERIFICATION

Taking advantage of the RMS/EMT Simulation tool of PowerFactory, the transient stability analysis of the rotor angle of reference generators are performed, which leads to coherency detection between groups of generators. This

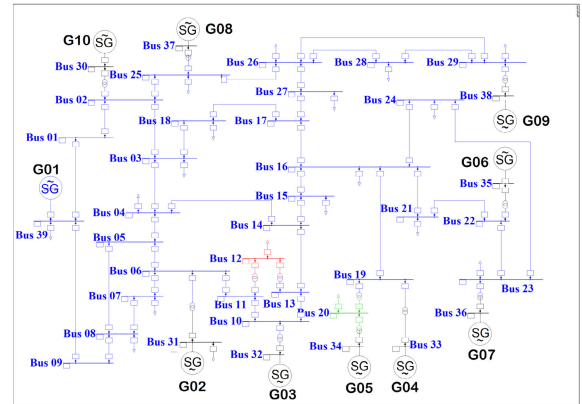

FIGURE 3. Single line diagram of the 39-Bus new england system.

section provides discussions and simulation results of the proposed method applied to the IEEE 39-Bus New England system and 118-Bus modified test system, where all generators are represented by full sixth-order models. Simulations are carried out using PowerFactory 15.1.7 on a Lenovo laptop with 64-bit win10 operating system, processor: Intel® core™ i7-4700MQ CPU 2.40 GHz, and 16.00 GB installed memory.

A. IEEE 39-BUS NEW ENGLAND SYSTEM

The proposed method for generator coherency is applied to the IEEE 39-Bus New England System, containing ten generators. As illustrated in Fig. 3, all the system loads are considered as nonlinear dynamic loads, where more detailed information can be found in [29]. Two scenarios are pursued here: the three-phase fault and the three-phase with line outage.

At the initial step of simulations, the number of reference generators is considered four, which is the same as the number of areas $r = 4$ determined by eigengap heuristic [30]. All generators are reduced to reference generators taking advantage of the extended ward reduction.

1) CASE I

In this case, a three-phase fault at time $t = 1$ with a duration of 0.15s occurs at the mid-point of lines 1 and 2. Consequently, the line breaker operates, and the line is removed. Implementing the time-domain stability simulation, the rotor angle oscillations of reference generators are evaluated for 10s dynamic responses in the ward equivalent system as illustrated in Fig. 4. Note that throughout the paper, all the coherent trajectories are displayed in the same colors as black. As shown, the swing curves of generators G05 and G06 are similar to each other in terms of frequency and phase and hence, the coherency of generators have been established. Since the fault has occurred close to G01, its rotor angle oscillation is different from others. The groups included reference generators G05 and G06 are combined, and the group included G03 remains unchanged. Since the frequency

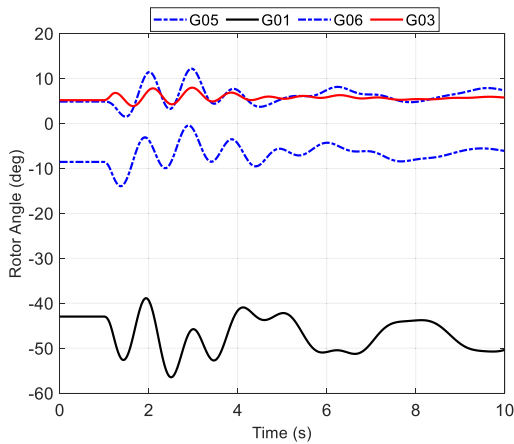

FIGURE 4. Rotor angle oscillation of reference generators (Case I).

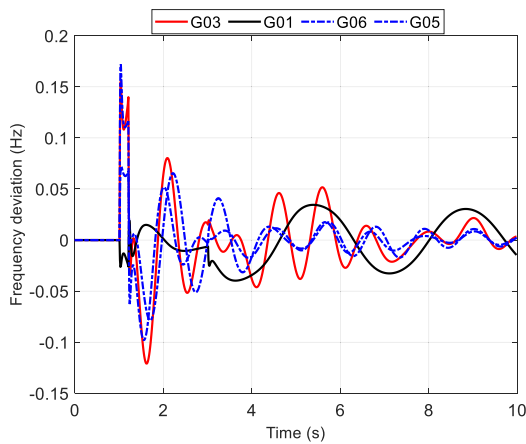

FIGURE 5. The frequency deviation curves reference generators (Case I).

deviation is a natural representative of variations' status in the generator rotor angle upon which the concept of coherency is defined, to further validate the generators' coherency identification results achieved in Fig. 4, the frequency deviation curves are depicted in Fig. 5. From Fig. 4 it can be observed that the reference generators G05 and G06 behave similar, while the separation of G01 into an area on its own due to the fault occurrence is evident. In addition, although G03 has demonstrated a similar behavior as G05 and G06 (Fig. 5), its frequency deviation is far from merging with the coherent trajectory. This indicates that G03 is not coherent with either G05 or G06.

The Spearman correlation coefficients and linear regression of reference generators' rotor angles in the ward equivalent system and the full detailed original system are illustrated in Table 2 and 3, respectively, determining the final coherent groups.

Comparing the coherent groups of the original system with those of the reduced system to reference generators

TABLE 2. Spearman correlation coefficients and linear regression of all pairs of reference generators (Case I).

Unit	G01		G03		G05		G06	
	CC_{ij}	b	CC_{ij}	b	CC_{ij}	b	CC_{ij}	b
G01	1	1	0.00	0.71	-0.04	0.91	-0.10	0.91
G03	-0.00	0.71	1	1	0.54	0.78	0.64	0.65
G05	-0.04	0.91	0.54	0.78	1	1	0.83	0.83
G06	-0.10	0.91	0.64	0.65	0.83	0.83	1	1

TABLE 3. Spearman correlation coefficients and linear Regression of reference generators in full detailed original system (Case I).

Unit	G01		G03		G05		G06	
	CC_{ij}	b	CC_{ij}	b	CC_{ij}	b	CC_{ij}	b
G01	1	1	-0.82	0.39	-0.85	0.84	-0.96	0.84
G03	-0.82	0.39	1	1	0.79	0.46	0.85	0.45
G05	-0.85	0.84	0.79	0.46	1	1	0.94	0.99
G06	-0.96	0.84	0.85	0.45	0.94	0.99	1	1

TABLE 4. Coherent groups of IEEE 39-bus test system (Case I).

Group	TSA full detailed	Proposed method
1	10, 1, 8, 9	10, 1, 8, 9
2	7, 4, 6, 5	7, 4, 6, 5
3	2, 3	2, 3

indicates the accuracy of the proposed method by analyzing the coherency behavior of reference generators with the same results. The generators are regrouped and updated into three coherent groups as presented in Table 4.

By calculating the average indices of Table 2 and 3 and comparing the results, and also considering the formation of coherency groups according to the flowchart (Fig. 2), one can observe that the final coherency behavior in the main system and the reduced system is similar. Accordingly, the achieved results validate the proposed method's performance.

2) CASE II

In this case, two disturbances are applied to the system, including a three-phase fault on bus 2 at $t = 1$ with a duration of 0.2s, and the trip of lines 1 and 2 at $t = 3$. Figures 6 and 7 respectively show the rotor angles oscillations of reference generators and frequency deviation curves in the ward equivalent system following the disturbances. The Spearman correlation coefficients and linear regression of all pairs of reference generators to identify the coherent groups in the equivalent system and the original system are shown in Table 5 and 6, respectively. Also, Table 7 illustrates the final updated coherent groups of Case II. It can be observed that with the faults mentioned above, the number of groups is reduced, and the reference generators G02 and G03 are regrouped with G04, G05, G06, and G07; while the first group remains unchanged.

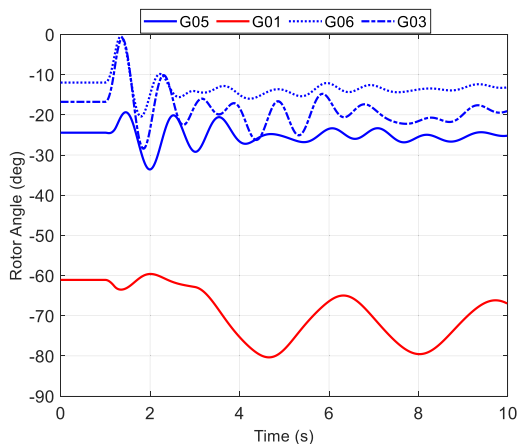

FIGURE 6. Rotor angle oscillation of reference generators (Case II).

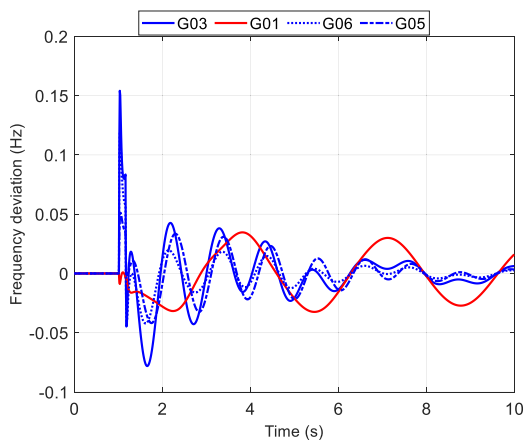

FIGURE 7. The frequency deviation curves reference generators buses (Case II).

TABLE 5. Spearman correlation coefficients and linear regression of reference generators (Case II).

Unit	G01		G03		G05		G06	
	CC_{ij}	b	CC_{ij}	b	CC_{ij}	b	CC_{ij}	b
G01	1	1	0.43	0.34	0.17	0.38	0.23	0.37
G03	0.43	0.34	1	1	0.49	0.90	0.71	0.92
G05	0.17	0.38	0.49	0.90	1	1	0.54	0.96
G06	0.23	0.37	0.71	0.92	0.54	0.96	1	1

B. IEEE MODIFIED 118-BUS TEST SYSTEM

A modified version of the IEEE 118-bus system is chosen to demonstrate the proposed method’s efficiency for large power systems, as shown in Fig. 8. The network consists of 19 generators, 20 condensers, 15 motors as static generators in PowerFactory, 137 bus, 177 transmission lines, 28 transformers, and 91 constant impedance loads. It is worth mentioning that, in the modified version of the IEEE 118-bus system, one bus is considered for each transformer connected

TABLE 6. Spearman Correlation coefficients and linear regression of reference generators in full detailed original system (Case II).

Unit	G01		G03		G05		G06	
	CC_{ij}	b	CC_{ij}	b	CC_{ij}	b	CC_{ij}	b
G01	1	1	-0.75	0.41	-0.70	0.61	-0.93	0.58
G03	-0.75	0.41	1	1	0.61	0.66	0.76	0.69
G05	-0.70	0.61	0.61	0.66	1	1	0.84	0.96
G06	-0.93	0.58	0.76	0.69	0.84	0.96	1	1

TABLE 7. Coherent groups of IEEE 39-bus test system (Case II).

Group	TSA full detailed	Proposed method
1	10, 1, 8, 9	10, 1, 8, 9
2	7, 4, 6, 5, 2, 3	7, 4, 6, 5, 2, 3

TABLE 8. Spearman correlation coefficients and linear regression of reference generators in IEEE modified 118-bus test system (with ward equivalent).

Unit	G01		G16		G12		G14		G06	
	CC_{ij}	b	CC_{ij}	b	CC_{ij}	b	CC_{ij}	b	CC_{ij}	b
G01	1	1	0.00	0.89	0.80	0.76	0.17	0.89	0.78	0.80
G16	0.00	0.89	1	1	0.08	0.85	0.23	0.99	0.12	0.89
G12	0.80	0.76	0.08	0.85	1	1	0.47	0.85	0.76	0.95
G14	0.17	0.89	0.23	0.99	0.47	0.85	1	1	0.35	0.89
G06	0.78	0.80	0.12	0.89	0.76	0.95	0.35	0.89	1	1

TABLE 9. Coherent groups of IEEE modified 118-bus test system.

Group	TSA full detailed	Slow coherency	Proposed method
1	5, 1, 2, 3, 4	5, 1, 2, 3, 4	5, 1, 2, 3, 4
2	8, 6, 7, 9, 10, 11, 12, 13	8, 7, 9, 10, 11, 12, 13	8, 6, 7, 9, 10, 11, 12, 13
3	15, 16	15, 16	15, 16
4	19, 14, 17, 18	19, 14, 17, 18	19, 14, 17, 18
5		6	

to a generator; hence, the total number of buses of the system is 137. The complete data of 118-bus is available in [31].

The number of areas for the network is determined using eigengap heuristic [30] as $r = 5$, and the coherent groups are updated to final coherent groups by events occurrence.

To validate the capability of the proposed method for IEEE 118-bus large-scale power system, a three-phase short circuit fault on the middle of 230kV transmission line 69-70 at $t = 1$ is applied in the ward equivalent network of the original system, which leads to the outage of the line after 0.1s. Line 23-24 is overloaded and causes an outage at $t = 3$. Figures 9 and 10 respectively show the rotor angles and frequency deviation curves of reference generators of transient stability simulation following the event. Coherency behavior between the groups is evaluated by the Spearman correlation coefficient and linear regression of the rotor angles of reference generators shown in Table 8. Also, the comparative results of the slow coherency of the original network coherency with those of the proposed method are given in Table 9.

As is observed in Fig. 9, the rotor angle oscillations of G06 and G12 have the same behavior when the disturbance

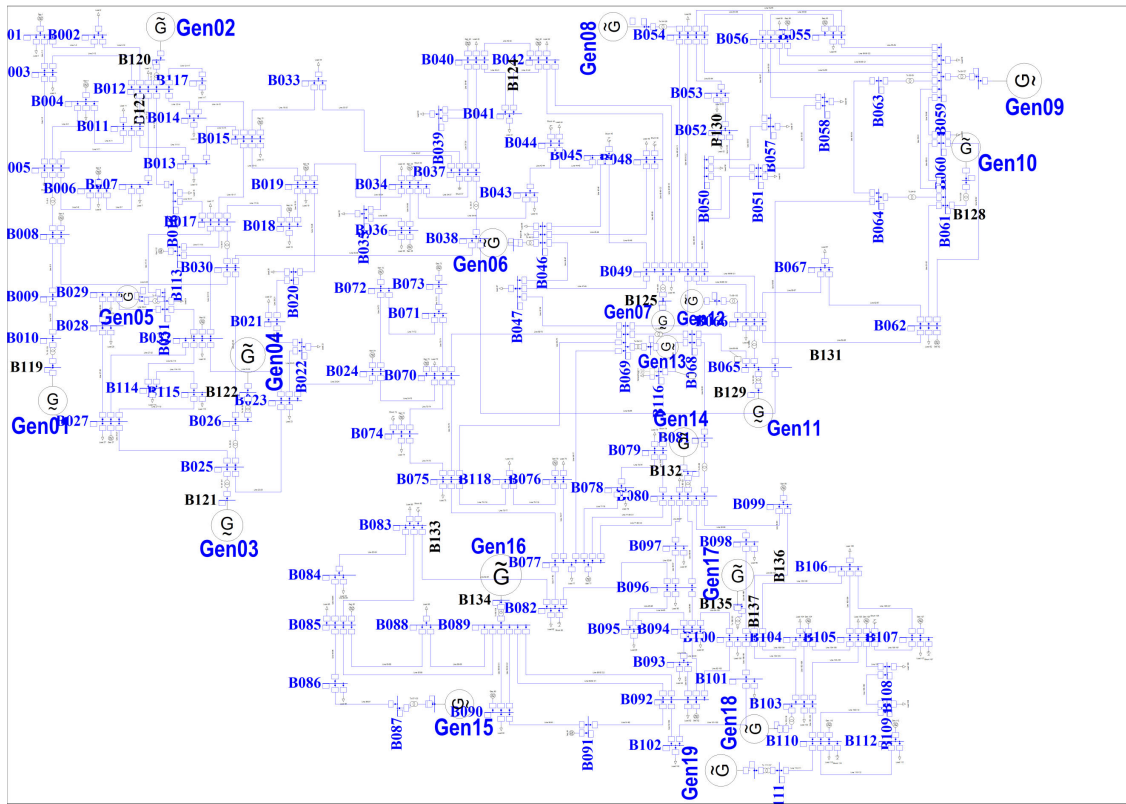

FIGURE 8. IEEE modified 118-bus network.

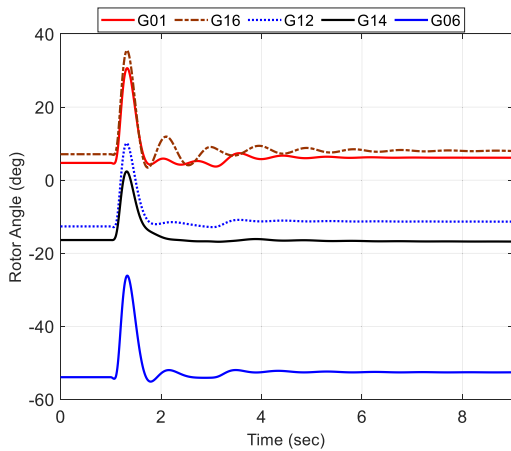

FIGURE 9. Rotor angle oscillations of reference generators (with ward equivalent).

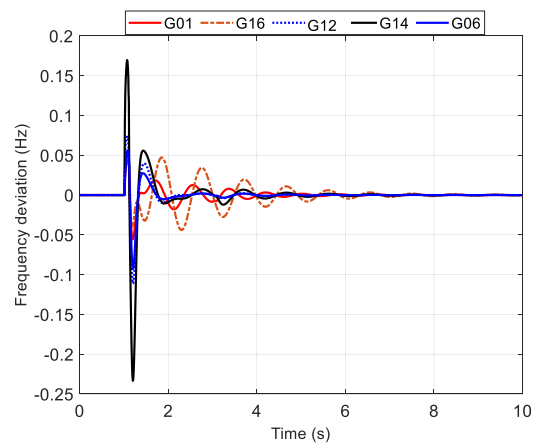

FIGURE 10. The frequency deviation curves reference generators buses (with ward equivalent).

occurs, which is validated through results given in Fig. 10 and Table 8. Thus, all generators are categorized into four groups.

According to Table 8, compared to the slow coherency method, the proposed algorithm reduces the number of coherent generation groups with minimal power-flow disruption. The results demonstrate that the proposed coherency identification technique achieves high performance for the

modified IEEE 118-Bus test system, which is much more complicated than the New England 39-Bus test system. Thanks to minimal power-flow disruption, islands with minimum change from the pre-disturbance power-flow pattern can be created, resulting in improvements in the islands' transient stability while reducing the possibility of overloading the transmission lines within the island. Accordingly, the proposed method can be counted as a viable

TABLE 10. Spearman correlation coefficients and linear regression of reference generators (without ward equivalent).

Unit	G01		G16		G12		G14		G06	
	CC_{ij}	b	CC_{ij}	b	CC_{ij}	b	CC_{ij}	b	CC_{ij}	b
G01	1	1	0.083	0.906	0.736	0.794	-0.090	0.906	0.575	0.829
G16	0.083	0.906	1	1	0.087	0.876	0.302	0.999	0.138	0.914
G12	0.736	0.794	0.087	0.876	1	1	0.220	0.875	0.789	0.956
G14	-0.090	0.906	0.302	0.999	0.220	0.875	1	1	0.016	0.914
G06	0.575	0.829	0.138	0.914	0.789	0.956	0.016	0.914	1	1

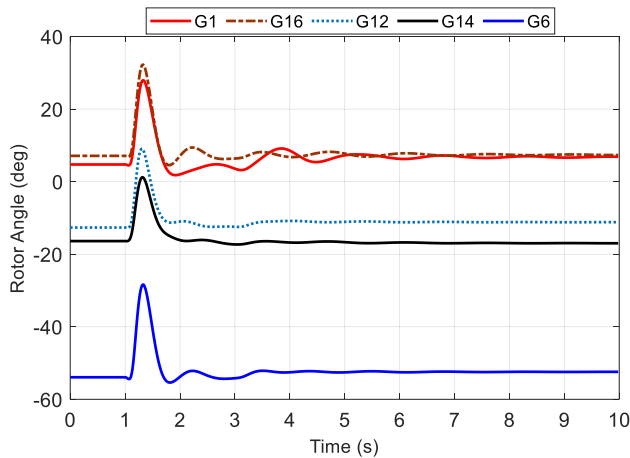

FIGURE 11. Rotor angle oscillations of reference generators (without ward equivalent).

solution for controlled-islanding applications by providing a more reasonable and stable islanding strategy.

To further evaluate the developed method’s performance, the rotor angle obtained by TSA detailed model in the ward equivalent network is compared with TSA full detailed model in the original network without ward equivalent. The comparison is carried out using the sixth-order rotor electrical dynamic model. The rotor angle of reference generators subjected to a fault on lines 69-70 at $t = 1$ s in the IEEE modified 118-bus system is shown in Fig. 11. Moreover, the rotor angle of all generators is categorized (Fig. 12) to illustrate the accuracy of the proposed method over slow coherency. The Spearman correlation coefficients and linear regression of reference generators in the original full detailed network are demonstrated in Table 10. Two generators are coherent if both coefficients CC_{ij} and b are higher than their average values, where the average values are $CC_{ave} = 0.352$ and $b_{ave} = 0.897$. Accordingly, it can be seen that G06 and G12 are coherent in both original full detailed and the proposed method.

The CPU time associated with the proposed method’s implementation on the IEEE modified 118-bus system through Python and MATLAB is provided in Table 11. Due to the slow coherency algorithm’s independency to faults, it is used to identify the initial groups. Then the generators with the greatest power are chosen, and the rest are converted to the ward model. Accordingly, the equivalent ward model

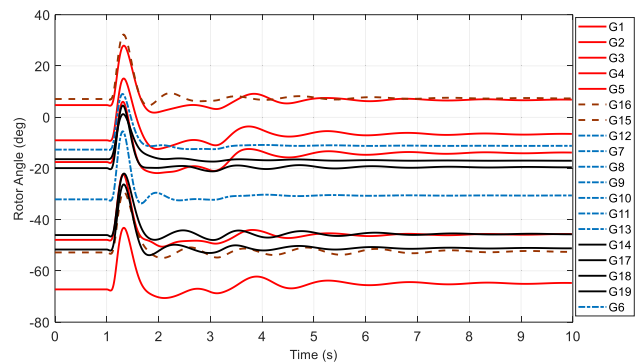

FIGURE 12. Rotor angle oscillations of all generators (without ward equivalent).

TABLE 11. The CPU time of the proposed method on the 118-bus IEEE system.

Method	PowerFactory (Python(s))	MATLAB(s)
TSA method on full detailed model	5.670	0.400
Slow coherency algorithm	9.000	0.179
Extended Ward	2.030	0.100
TSA on full detailed model	1.230	0.127
Coherent generators identification	0.230	0.004
Proposed method (total)	1.460	0.131

with retained components (line, bus, and load) is conducted. It is noteworthy that the above two stages are only conducted once, and as of this stage and for any fault occurrence, TSA is employed in the ward equivalent model to identify the coherent generators groups. Since the method is not implemented on a dedicated hardware, the CPU time changed from one run to another. Therefore, an average of 20 runs is reported. The results demonstrate the computational efficiency of the proposed method. However, since the technical literature does not report the CPU time for other methods, no relative comparison is presented.

V. CONCLUSION

This paper develops a straightforward and efficient generator coherency identification approach. The proposed method comprises two methods: slow coherency and time-domain-based transient stability. In real power system networks, the initial groups are defined by slow coherency; and then are reduced to an extended ward equivalent model except for the large generator of each group. These steps are made for each

network once. A new framework for the fast identification of coherency behaviour under events is developed in this work. The Spearman correlation coefficients and linear regression are calculated to identify groups coherency using the rotor angles associated with all reference generators within the simulation time and without any interceptions of the reference generator rotors' pairs. Two test systems have been used to testify and validate the proposed scheme's efficiency and performance compared to the slow coherency method. All power system components remain unchanged in the extended ward equivalent section regardless of faults that occurred anywhere on the network. Some generators' extended ward equivalent increases the transient stability speed and reduces the number of swing curves for large power systems while preserving the required accuracy. The CPU time investigation of the proposed method demonstrate its computational efficiency. This method can also be extended online for the islanding schemes.

REFERENCES

- [1] M. Naglic, M. Popov, M. A. M. M. van der Meijden, and V. Terzija, "Synchronized measurement technology supported online generator slow coherency identification and adaptive tracking," *IEEE Trans. Smart Grid*, vol. 11, no. 4, pp. 3405–3417, Jul. 2019.
- [2] S. Ghosh, Y. J. Isbeih, M. S. E. Moursi, and E. F. El-Saadany, "Cross-gramian model reduction approach for tuning power system stabilizers in large power networks," *IEEE Trans. Power Syst.*, vol. 35, no. 3, pp. 1911–1922, May 2019.
- [3] S. Liu *et al.*, "Robust system separation strategy considering online wide-area coherency identification and uncertainties of renewable energy sources," *IEEE Trans. Power Syst.*, vol. 35, no. 5, pp. 3574–3587, Sep. 2020.
- [4] L. Lugnani, M. R. A. Paternina, D. Dotta, J. H. Chow, and Y. Liu, "Power system coherency detection from wide-area measurements by typicality-based data analysis," *IEEE Trans. Power Syst.*, vol. 37, no. 1, pp. 388–401, Jan. 2021.
- [5] I. Tyuryukanov, M. Popov, M. A. M. M. van der Meijden, and V. Terzija, "Slow coherency identification and power system dynamic model reduction by using orthogonal structure of electromechanical eigenvectors," *IEEE Trans. Power Syst.*, vol. 36, no. 2, pp. 1482–1492, Mar. 2020.
- [6] M. H. Rezaeian, S. Esmacili, and R. Fadaeinedjad, "Generator coherency and network partitioning for dynamic equalizing using subtractive clustering algorithm," *IEEE Syst. J.*, vol. 12, no. 4, pp. 3085–3095, Dec. 2017.
- [7] M. Dabbaghjamesh *et al.*, "A novel two-stage multi-layer constrained spectral clustering strategy for intentional islanding of power grids," *IEEE Trans. Power Del.*, vol. 35, no. 2, pp. 560–570, Apr. 2019.
- [8] D. Huang, H. Sun, Q. Zhou, S. Zhao, and J. Zhang, "An WAMS-based online generators coherency identification approach for controlled islanding," *IEEE Access*, vol. 8, pp. 89630–89642, 2020.
- [9] F. Dörfler, M. R. Jovanović, M. Chertkov, and F. Bullo, "Sparsity-promoting optimal wide-area control of power networks," *IEEE Trans. Power Syst.*, vol. 29, no. 5, pp. 2281–2291, Sep. 2014.
- [10] S. Ghosh, M. S. El Moursi, E. F. El-Saadany, and K. A. Hosani, "Online coherency based adaptive wide area damping controller for transient stability enhancement," *IEEE Trans. Power Syst.*, vol. 35, no. 4, pp. 3100–3113, Jul. 2019.
- [11] J. H. Chow, J. Sanchez-Gasca, and J. Paserba, "An adaptive text: Suitable for academics and practitioners [book review]," *IEEE Power Energy Mag.*, vol. 18, no. 6, pp. 108–111, Nov. 2020.
- [12] J. Machowski, Z. Lubosny, J. W. Bialek, and J. R. Bumby, *Power System Dynamics: Stability and Control*. Hoboken, NJ, USA: Wiley, 2020.
- [13] Z. Lin *et al.*, "WAMS-based coherency detection for situational awareness in power systems with renewables," *IEEE Trans. Power Syst.*, vol. 33, no. 5, pp. 5410–5426, Sep. 2018.
- [14] J. Wei, D. Kundur, and K. L. Butler-Purry, "A novel bio-inspired technique for rapid real-time generator coherency identification," *IEEE Trans. Smart Grid*, vol. 6, no. 1, pp. 178–188, Jan. 2014.
- [15] Y. H. Kim, S. T. Cha, J. W. Lee, T. K. Kim, J. B. Choo, and H. K. Nam, "Construction of largest equivalent systems for power system simulator," *Eur. Trans. Electr. Power*, vol. 16, no. 1, pp. 79–91, 2006.
- [16] Z. Zhu, G. Geng, and Q. Jiang, "Power system dynamic model reduction based on extended Krylov subspace method," *IEEE Trans. Power Syst.*, vol. 31, no. 6, pp. 4483–4494, Nov. 2016.
- [17] S. Chandra, D. F. Gayme, and A. Chakraborty, "Time-scale modeling of wind-integrated power systems," *IEEE Trans. Power Syst.*, vol. 31, no. 6, pp. 4712–4721, Nov. 2016.
- [18] A. M. Khalil and R. Iravani, "A dynamic coherency identification method based on frequency deviation signals," *IEEE Trans. Power Syst.*, vol. 31, no. 3, pp. 1779–1787, May 2015.
- [19] A. Vahidnia, G. Ledwich, E. Palmer, and A. Ghosh, "Generator coherency and area detection in large power systems," *IET Gener., Transmiss. Distrib.*, vol. 6, no. 9, pp. 874–883, Sep. 2012.
- [20] E. Barocio, B. C. Pal, N. F. Thornhill, and A. R. Messina, "A dynamic mode decomposition framework for global power system oscillation analysis," *IEEE Trans. Power Syst.*, vol. 30, no. 6, pp. 2902–2912, Nov. 2014.
- [21] M. R. Aghamohammadi and S. M. Tabandeh, "A new approach for online coherency identification in power systems based on correlation characteristics of generators rotor oscillations," *Int. J. Elect. Power Energy Syst.*, vol. 83, pp. 470–484, Dec. 2016.
- [22] Q. Wu, H. Li, F. Meng, and K. N. Ngan, "A perceptually weighted rank correlation indicator for objective image quality assessment," *IEEE Trans. Image Process.*, vol. 27, no. 5, pp. 2499–2513, May 2018.
- [23] J. Zhang, Z. Wang, X. Zheng, L. Guan, and C. Y. Chung, "Locally weighted ridge regression for power system online sensitivity identification considering data collinearity," *IEEE Trans. Power Syst.*, vol. 33, no. 2, pp. 1624–1634, Mar. 2017.
- [24] J. Liu, F. Tang, J. Zhao, D. Liu, and I. Kamwa, "Coherency identification for wind-integrated power system using virtual synchronous motion equation," *IEEE Trans. Power Syst.*, vol. 35, no. 4, pp. 2619–2630, Jul. 2020.
- [25] W. S. Peter, M. Pai, and W. C. Joe, *Power System Dynamics and Stability with Synchrophasor Measurement and Power System Toolbox*. Hoboken, NJ, USA: Wiley, 2017.
- [26] E. W. S. Angelos and E. N. Asada, "Improving state estimation with real-time external equivalents," *IEEE Trans. Power Syst.*, vol. 31, no. 2, pp. 1289–1296, May 2015.
- [27] S. Xu and S. Miao, "Calculation of TTC for multi-area power systems based on improved ward-PV equivalents," *IET Gener., Transmiss. Distrib.*, vol. 11, no. 4, pp. 987–994, Mar. 2017.
- [28] R. T. Byerly, D. E. Sherman, and D. K. McLain, "Normal modes and mode shapes applied to dynamic stability analysis," *IEEE Trans. Power App. Syst.*, vol. PAS-94, no. 2, pp. 224–229, Mar. 1975.
- [29] Power Cases. (2013). *Illinois Center Smarter Electric Grid (ICSEG)*. [Online]. Available: <http://publish.illinois.edu/smartergrid/power-cases>
- [30] F. Gonzalez-Longatt and J. L. R. Torres, *Advanced Smart Grid Functionalities Based on Powerfactory*. Cham, Switzerland: Springer, 2018.
- [31] (2019). *IEEE Test Bed Systems*. [Online]. Available: <http://www.Kios.uci.ac.cy/testsystems>