



Vaasan yliopisto
UNIVERSITY OF VAASA

OSUVA Open
Science

This is a self-archived – parallel published version of this article in the publication archive of the University of Vaasa. It might differ from the original.

A comprehensive linear model for demand response optimization problem

Author(s): Heydarian-Forushani, Ehsan; Golshan, Mohamad Esmail Hamedani; Shafie-khah, Miadreza; Catalão, João P.S.

Title: A comprehensive linear model for demand response optimization problem

Year: 2020

Version: Accepted version

Copyright ©2020 Elsevier. This manuscript version is made available under the Creative Commons Attribution–NonCommercial–NoDerivatives 4.0 International (CC BY–NC–ND 4.0) license, <https://creativecommons.org/licenses/by-nc-nd/4.0/>

Please cite the original version:

Heydarian-Forushani, E., Golshan, M.E.H., Shafie-khah, M. & Catalão, J.P.S. (2020). A comprehensive linear model for demand response optimization problem. *Energy* 209, 1-24.
<https://doi.org/10.1016/j.energy.2020.118474>

A Comprehensive Linear Model for Demand Response Optimization Problem

E. Heydarian-Forushani ^a, M. E. H. Golshan ^a, M. Shafie-khah ^{b*}, Joao P.S. Catalão ^c

^a Department of Electrical and Computer Engineering, Isfahan University of Technology, Isfahan 84156-83111, Iran

^b School of Technology and Innovations, University of Vaasa, 65200 Vaasa, Finland

^c Faculty of Engineering of University of Porto and INESC TEC, 4200-465 Porto, Portugal

Abstract

Demand Response (DR) is known as an effective solution for many power grid problems such as high operating cost as well as high peak demand. In order to achieve full potential of DR programs, DR must be implemented optimally. On this basis, determining optimal DR location, appropriate DR program and efficient penetration rate for each DR program is of great practical interest due to the fact that it guides the system operators to choose proper DR strategies. This paper presents a novel linear framework for DR optimization problem incorporated into the network-constrained unit commitment with the aim of determining optimal location, type and penetration rate of DR programs considering several practical limitations. To this end, a number of tariff-based and incentive-based DR programs have been taken into account according to the customer's benefit function based on the price elasticity concept. The IEEE 24-bus Reliability Test System (RTS 24-bus) is used to demonstrate the applicability of the proposed model. Finally, DR optimization is analyzed with regards to different customer's elasticity values and also different number of candidate load buses which reveal the applicability and effectiveness of the proposed methodology.

Keywords: Demand response, linear model, optimal location, optimization problem, power grid.

Nomenclatures

Indices

b, b'	Index of system buses $b = 1, \dots, NB$
i	Index of conventional units $i = 1, \dots, NG$
j	Index of loads $j = 1, \dots, NJ$
l	Index of transmission lines $l = 1, \dots, L$
t, t'	Index of time periods $t = 1, \dots, NT$
m	Index of segment for linearized fuel cost $m = 1, \dots, NM$
DR	Index of DR programs $DR \in \{TOU, RTP, CPP, EDRP\}$

Parameters

* Corresponding author at: School of Technology and Innovations, University of Vaasa, 65200 Vaasa, Finland
E-mail address: mshafiek@univaasa.fi, Tel: +358 29 449 8534

$C_{i,t,m}^{G-Eng}$	Offered piecewise fuel cost for generating units(\$/MWh)
SC_i	Start-up cost of unit i (\$)
MUT_i / MDT_i	Minimum up/down time (h)
P_i^{\min} / P_i^{\max}	Minimum/Maximum output of units(MW)
RU_i / RD_i	Ramp up/down limits of units(MW/h)
SUR_i / SDR_i	Start-up/shut-down ramp rates of units (MWh/h)
MPC_i	Minimum production cost of unit i (\$)
$d_{j,t}^{ini}$	Initial electricity demand of load bus j before DR(MW)
λ_t	Electricity tariffs of different tariff-based DR programs (\$/MWh)
Inc_i	Incentive value in EDRP (\$/MWh)
λ_t^{ini}	Initial electricity price before DR(\$/MWh)
$E_{t,t'}$	Price elasticity of demand
η_j^{DR-max}	Maximum potential of a typical DR program at load bus j (%)
$\eta_j^{Total-max}$	Total responsiveness rate at load bus j (%)
N^{DR}	Maximum allowable load bus candidates for DR implementation

Variables

$SUC_{i,t}$	Start-up cost of conventional units (\$)
$U_{i,t}$	Binary on/off status indicator of generation units
$P_{i,t,m}^e$	Generation of segment m in linearized fuel cost curve(MWh)
$F_{l,t}$	Power flow through line l at time t (MW)
$\delta_{b,t}$	Voltage angle of network buses (rad)
η_j^{DR}	Penetration rate of a typical DR program at load bus j (%)
X_j	Binary indicator which represents the load bus j selected for implementing DR or not
Y_j^{DR}	Auxiliary positive variable for DR optimization linearization
$P_{i,t}$	Actual power generation of generation units (MW)

1. Introduction

1.1. Motivation

Recent developments in smart grid technologies such as information and communication infrastructures will guarantee widespread utilization of Demand Response (DR) programs in future power grids. Optimal

implementation of DR programs not only can assist power systems during peak demand hours, but also can provide valuable flexibility to manage the grid more efficiently. In order to exploit the full potential of DR, it is essential to implement an optimal DR scheme according to the practical limitations such as allowable number of buses participating in DR programs as well as different customer's behavior. Based on this context, the power system operators are faced with a DR optimization problem which must be solved in order to promote the economic and technical aspects of network operation. To this end, this paper aims at developing a linear DR optimization problem and finding an optimal DR scheme in terms of location, DR type and penetration rate of various DR programs. The paper concludes with applicable guidelines for system operators to implement an optimal DR scheme in proper locations.

1.2. Literature review

In this section, the previous research studies on DR optimization are reviewed from three different perspectives including the used optimization algorithms, the considered DR programs, and the decision variables. The algorithms employed for solving the DR optimization problem can be divided into classic and metaheuristic optimization methodologies [1]. The DR optimization problem can be formulated in both linear and nonlinear forms. For instance, the authors in [2] presented a linear model for DR programs with the aim of investigating the impacts of a comprehensive set of DR programs as well as customer participation levels on system load profile. Note that, the customer participation level and location of the buses for DR implementation are defined as input parameters of the model. An optimal linear Time of Use (TOU) DR program has been developed in [3] in order to enable demand-side flexibility in the face of minor and major variations within a transmission network. It is noteworthy that although the electricity tariffs in various time periods are determined as decision variables, however, the location of DR implementation and customer responsiveness have predefined values. Note that the author's intention from "tariff" term is the electricity rate for customers that can be different in hours of a day based on a contract with energy serving companies. A Mixed-Integer Linear Programming (MILP) model has been presented in [4] for optimizing generation scheduling and a set of DR programs including TOU, Real-Time Pricing (RTP) and Critical Peak Pricing (CPP) in a residential community in the presence of renewable resources and energy storages.

A number of works such as [5-6] used nonlinear models for DR optimization problem. In [5], the optimal day-ahead scheduling of resources in energy hubs has been investigated under RTP program using a mixed-integer nonlinear programming (MINLP) model. The authors in [6] proposed a NLP model for unit commitment problem in a

microgrid while the amount of load reduction and incentive payments are calculated during DR optimization. Furthermore, the authors in [7] proposed an improved flexibility index with the concept of fast reserve supply using a MINLP model without considering the transmission network. Several nonlinear economic models of incentive-based and tariff-based DR programs have been examined in [8] and [9], respectively. Although the behavior of customers in response to changes in elasticity, incentive value, electricity tariffs and customer's responsiveness rate have been evaluated through different sensitivity analyses, however, the DR parameters and also location are not obtained through optimization procedure.

Other studies employed various metaheuristic algorithms to find a near-optimal solution with a limited computational burden. For instance, genetic algorithm has been used for solving DR optimization problem for an industrial and a residential consumer in [10] and [11], respectively. Moreover, the simulated annealing has been used in [12] for achieving optimal set of real-time prices in DR optimization problem, while the teaching learning-based optimization algorithms has been applied in [13] with the aim of determining the optimal scheduling of residential consumers under various DR programs consist of TOU, RTP and CPP.

The authors of [14] proposed an optimization model for dynamic price-based DR in the presence of renewable energy resources in a microgrid. The objective function assigned to profit maximization of loads considering comfort aspect. Also, the authors in [15] presented a user dominated DR program at downstream level that can reduce the energy bill of smart community with regard to user's comfort. Optimal reconfiguration of microgrid-based distribution networks considering DR program with the aim of enhancing the network scheduling flexibility has been investigated in [16]. A framework for quantifying the electricity flexibility in DR programs for the appliances such as air conditioning systems in an office building has been presented in [17].

The value of demand flexibility on spot and reserve electricity markets in power grids with significant penetration of renewable energy resources has been analyzed in the future German power system [18]. An agent-based model has been developed in [19] in order to evaluate the integration of consumer's flexibility in both spot and balancing markets. The impact of DR implementation on market clearing price has been investigated in [20]. The model consists of two stages, wherein the optimal amount of DR is determined in the first stage and the second stage completes the optimal power flow considering the obtained DR quantity. In [21], the impacts of DR optimization on dispatch cost saving and renewable energy integration have been compared from the grid manager and prosumer viewpoints in an isolated microgrid. The authors in [22] presented a bi-objective model for minimizing power loss

and improving reliability of distribution network through optimal network reconfiguration. The effectiveness of implementing TOU program has been also evaluated on the considered objectives.

There are a few published papers regarding electricity pricing mechanisms. A game-theoretic method has been developed in [23] with the aim of designing a real-time electricity DR strategy. The model considered both the supplier and consumer profits through maximizing social welfare. The system dynamics approach has been used in [24] to evaluate various real-time electricity pricing mechanisms in China taking into account several factors such as load structure, cost, user satisfaction and the total social surplus. In addition, an updated economic model of pricing and investment in restructured electricity market has been developed in [25] with the aim of achieving policy decisions in energy technologies investment.

Reviewing the existing studies on DR optimization indicates that most of the previously published papers assumed that applying DR is feasible at all load buses which seems to be in conflict with a number of future DR perspectives such as Maximum Achievable Potential (MAP) and Realistic Achievable Potential (RAP) concepts. MAP and RAP analysis represent the actual limitations of DR implementation which must be taken into account in DR studies [26-27]. Accordingly, a limited number of papers such as [28-29] proposed more accurate models to find the most suitable load points for implementing DR programs. The authors in [28] proposed a multi attribute decision-making model for allocation of load management programs. The considered attributes are defined as the expected energy not supplied, total grid losses, and load management capacity. Although the considered attributes are relatively complete, however, the paper considered just one DR program which known as curtailable DR program. Furthermore, it is assumed that all loads could participate in DR with a predefined constant participation factor which seems not a reasonable assumption. In [29], a nonlinear multi objective framework has been developed in order to select the most efficient load points for DR implementation considering both the economic and technical aspects of power system operation. However, there are some simplifications such as the fact that only one DR program so-called Emergency DR Program (EDRP) has been considered, while the participation level is considered to be a constant value at all load points. Moreover, the model is nonlinear which may create some difficulties in finding the optimum solution.

1.3. Contributions

According to the above literature, many studies have analyzed the impacts of DR implementation on several aspects of power systems from both economic and technical points of view. In addition, a number of studies have focused

on evaluating the performance of different DR models. The fact that has been rarely addressed is that DR implementation with the lowest possible cost forces the system operators to choose a limited number of candidates for the aggregated DR programs instead of considering all the system load points. Moreover, reviewing the existing works reveals that incorporation of different types of DR programs in DR optimization problem is missing due to the fact that most of the DR optimization models just investigated the performance of one program instead of a mixture of DR programs to achieve a higher efficiency. Eventually, most of the DR optimization models are nonlinear where there is no guarantee for their converging to the optimal solution based on the metaheuristic algorithm mechanisms. In order to address the above mentioned defects, this paper presents a new model including the following main contributions. Firstly, a DR optimization model has been presented that allocates the most eligible load buses among candidate ones for implementing DR. Moreover, the presented model not only determines the most efficient DR programs mixture at each load bus, but also specifies the optimal penetration rate of different DR programs at each load bus. Secondly, an integrated decision making framework including supply-side and demand-side has been presented by incorporating DR optimization model into the network-constrained unit commitment problem. Thirdly, the integrated framework has been linearized so that it can be simply implemented and solved by a commercial optimization software which guarantees its converging to the optimal solution.

1.4. Paper organization

The rest of the paper is organized as follows. The DR optimization model is presented in Section 2. Section 3 devotes to the network-constrained generation scheduling formulation. Numerical studies are presented in Section 4. The concluding remarks are given in Section 5.

2. Linear DR optimization model

DR is defined as: “changes in electric usage of end-use customers from their normal consumption patterns in response to changes in the price of electricity over time, or to incentive payments designed to induce lower electricity use at times of high wholesale market prices or when system reliability is jeopardized” [30].

In order to exploit the full potential of DR, DR programs must be implemented optimally in terms of both DR location and DR scheme which not only determines the most efficient DR programs mixture at each load bus but also specifies the optimal customer participation level of considered DR programs. In order to have a detailed comparison among different DR programs, TOU, RTP, and CPP programs have been selected as tariff-based DR programs, while EDRP has been chosen as an incentive-based DR program. The EDRP provides more right choice

for customers in comparison with other incentive-based programs. Moreover, it is selected due to the fact that reward leads to a remarkable improvement in subject's behavior in comparison with punishment in most communities. In the tariff-based DR programs, the customers are motivated to modify their typical electricity consumption in response to changes in electricity tariffs during a day. The incentive-based DR programs encourage customers to change their typical demand in return for a specified incentive payment. Therefore, the electricity tariff is considered to be fixed at all periods, while the incentive is paid for load reduction just at critical peak period.

There are several possible structural forms to model the consumer's demand behavior in response to electricity tariff changes or an incentive payment such as linear, power, exponential and logarithmic models. In this paper, an extended linear economic model of responsive loads based on price elasticity and customer benefit function is developed as formulated in (1) [31]. The elasticity is defined as the load's reaction to the electricity price. As the elasticity increases, the load sensitivity to price increases as well. The ON or OFF loads that are not able to move from one period to another are modeled through self elasticity concept which has a negative value. The shiftable loads that can be transferred from the peak period to the off-peak or low periods are modeled using cross elasticity concept which is always positive.

The net consumer's benefit as a result of consuming d_t can be formulated as observed in Eq. (1) [31]. The first term of Eq. (1) is the customer's utility at hour t as a function of consumption amount. The next two terms indicate the cost of customer's electricity consumption and the income as a result of incentive payment, respectively [31].

$$B_t = Uti(d_t) - d_t \lambda_t + Inc_t (d_t^{ini} - d_t) \quad (1)$$

Note that, the customer's utility indicates the production income for industrial customers, while it is the productivity for commercial demands which is usually model using a quadratic function as given in Eq. (2) [31]. In order to calculate the amount of demand in which the maximum customers' benefit is yield, a partial differential equation with respect to d_t must be equal to zero [31]. Therefore,

$$Uti_t = Uti_t^{ini} + \lambda_t^{ini} (d_t - d_t^{ini}) \left(1 + \frac{d_t - d_t^{ini}}{2E_{t,t} d_t^{ini}} \right) \quad (2)$$

$$\frac{\partial B}{\partial d_t} = \frac{\partial Uti}{\partial d_t} - \lambda_t - Inc_t = 0 \quad \Rightarrow \quad \frac{\partial Uti}{\partial d_t} = \lambda_t + Inc_t \quad (3)$$

By differentiating Eq. (2), replacing the result in Eq. (3), and extending the single period model to multi period, the modified demand at each hour can be obtained as Eq. (4).

$$d_t = d_t^{ini} \left[1 + \sum_{t'=1}^{NT} E_{t,t'} \frac{(\lambda_{t'} - \lambda_{t'}^{ini} + Inc_{t'})}{\lambda_{t'}^{ini}} \right] \quad (4)$$

Here, the detailed formulation is avoided for the sake of conciseness and the readers are referred to [31] to find the origin of formulation. Equation (5) is the modified form of the above equation, where the impacts of DR location, type and penetration rate have been highlighted as decision variables.

$$d_{j,t} = \left(1 - \sum_{DR} X_j \eta_j^{DR} \right) d_{j,t}^{ini} + \sum_{DR} \left[X_j \eta_j^{DR} d_{j,t}^{ini} \left\{ \sum_{t'=1}^{NT} E_{t,t'} \frac{[\lambda_{t'} - \lambda_{t'}^{ini} + Inc_{t'}]}{\lambda_{t'}^{ini}} \right\} \right] \quad (5)$$

In Eq. (5), X_j is a binary variable which demonstrates that load bus j is selected for DR implementation or not.

Also, η_j^{DR} is a continuous variable that represents the customer participation level in a specified DR program for load bus j . Therefore, Eq. (5) is nonlinear which must be substituted by its linear form. To this end, an auxiliary positive variable is defined as the product of X_j and η_j^{DR} so-called Y_j^{DR} . On this basis, Eq. (5) can be rewritten as (6).

Note that, the variable Y_j^{DR} in Eq. (6) is representative of four variables since $DR \in \{TOU, RTP, CPP, EDRP\}$.

Moreover, the other constraints associated with linear transformation of DR optimization problem are formulated in Eqs. (7)-(9). It must be mentioned that Eqs. (7)-(9) are the compact form of the constraints due to the fact that each of the constraint should be considered for each DR program.

$$d_{j,t} = \left(1 - \sum_{DR} Y_j^{DR} \right) d_{j,t}^{ini} + \sum_{DR} \left[Y_j^{DR} d_{j,t}^{ini} \left\{ \sum_{t'=1}^{NT} E_{t,t'} \frac{[\lambda_{t'} - \lambda_{t'}^{ini} + Inc_{t'}]}{\lambda_{t'}^{ini}} \right\} \right] \quad (6)$$

$$Y_j^{DR} \leq X_j \quad (7)$$

$$Y_j^{DR} \leq \eta_j^{DR} \quad (8)$$

$$Y_j^{DR} \geq X_j + \eta_j^{DR} - 1 \quad (9)$$

In addition, the maximum potential of implementing a typical DR program at each load bus and the total responsiveness rate of each load bus are restricted through Eq. (10) and Eq. (11), respectively. According to several logical reasons such as DR financial investment limitations and demand characteristics, implementing DR on all load buses is impossible which is modeled through (12) [29].

$$0 \leq \eta_j^{DR} \leq \eta_j^{DR_max} \quad (10)$$

$$\sum_{DR} \eta_j^{DR} \leq \eta_j^{Total_max} \quad (11)$$

$$\sum_j X_j \leq N^{DR} \quad (12)$$

Note that, the nodal prices in transmission network are different and change in a hourly basis. There are some practical restrictions and regulatory interventions which caused the authors assume uniform nodal price. The changes of the electricity prices may lead to customer's confusion and even DR fatigue phenomenon that make the customers tired of continuing track of tariffs and usage. Moreover, full implementation of DR and providing instantaneous nodal prices for customers requires a smarter grid which is equipped with a well-developed two-way information communication and smart metering facilities.

3. Network-constrained generation scheduling formulation

The model is associated with the wholesale market including a number of generation companies and both responsive and inelastic loads. It must be mentioned that the objective function is from the independent system operator point of view and the power market is unregulated. The DR optimization model is incorporated into a network-constrained generation scheduling problem. The decision making problem consists of an objective function and a number of prevailing equality and inequality constraints. The problem is in fact a social welfare maximization which is defined as the net consumer's benefit minus the generation cost. Since the modified load curve (after DR implementation) has obtained through maximizing the customer's benefit function, therefore, the net consumer's benefit term in social welfare function will be a fix term. On this basis, the social welfare function maximization is transformed to a cost minimization problem as given in (13).

Minimize :

$$\sum_{t=1}^{NT} \sum_{i=1}^{NG} \left(SUC_{i,t} + MPC_i U_{i,t} + \sum_{m=1}^{NM} P_{i,t,m}^e C_{i,t,m}^{G_Eng} \right) + \sum_{t=1}^{NT} \sum_{j=1}^{NJ} \left(Inc_t (d_{j,t}^{ini} - d_{j,t}) \right) \quad (13)$$

The first and second terms in (13) devote to the start-up cost and minimum production cost of generating units, respectively. Furthermore, the fuel cost function of generation units are accurately approximated by a set of piecewise blocks with the aim of maintaining the model linearity [32]. Eventually, the last term pertains to the costs of incentive payments for EDRP implementation.

The objective function is subject to the following constraints. The power balance equation between load and generation is formulated in Eq. (14). In (10), $P_{i,t}$ approximates the generated power from committed unit i at hour t

by blocks as declared in (15). Moreover, $d_{j,t}$ is the modified demand of load bus j at hour t after DR implementation as formulated previously in (6).

$$\sum_{i \in G_b} P_{i,t} - \sum_{j \in J_b} d_{j,t} = \sum_{l \in L_b} F_{l,t} \quad (14)$$

$$P_{i,t} = \sum_{m=1}^{NM} P_{i,t,m}^e, 0 \leq P_{i,t,m}^e \leq P_{i,m}^{\max} \quad (15)$$

The DC power flow method is employed in order to model the power network as given in Eq. (16). Also, the limitations of transmission lines are taken into account through Eq. (17).

$$F_{l,t} = (\delta_{b,t} - \delta_{b',t}) / X_l \quad (16)$$

$$-F_l^{\max} \leq F_{l,t} \leq F_l^{\max} \quad (17)$$

The generating units have some technical operating constraints. The output power of generating units are restricted with its allowable range as formulated in (18). The inter-temporal constraints such as minimum up and down times of generation units are modeled through (19) and (20), respectively. The constraints associate with ramp up and ramp down rates of generating units are formulated in (21) and (22), separately. Also, the generating units start-up cost is given in (23).

$$P_i^{\min} U_{i,t} \leq P_{i,t} \leq P_i^{\max} U_{i,t} \quad (18)$$

$$\sum_{t'=t+2}^{t+MUT_i} (1 - U_{i,t'}) + MUT_i (U_{i,t} - U_{i,t-1}) \leq MUT_i \quad (19)$$

$$\sum_{t'=t+2}^{t+MDT_i} U_{i,t'} + MDT_i (U_{i,t-1} - U_{i,t}) \leq MDT_i \quad (20)$$

$$P_{i,t} - P_{i,t-1} \leq RU_i U_{i,t} + SUR_i (1 - U_{i,t-1}) \quad (21)$$

$$P_{i,t-1} - P_{i,t} \leq RD_i U_{i,t-1} + SDR_i (1 - U_{i,t}) \quad (22)$$

$$SUC_{i,t} \geq SC_i (U_{i,t} - U_{i,t-1}), SUC_{i,t} \geq 0 \quad (23)$$

4. Numerical results

The modified 24-bus IEEE Reliability Test System (RTS-79) is used in order to illustrate the applicability of the proposed DR optimization model [33]. This test system includes 26 generation units with 3105 MW install capacity excluding 6 hydro generators and 17 load buses with 2850 MW peak load. The start-up cost, minimum production cost, and linear piecewise blocks associated with the fuel cost of generating units are listed in Table 1. The other required data related to technical characteristics of generating units as well as network information have been directly extracted from [33].

Table 1. Generation units cost data

	Generation unit No.							
	i1-i5	i6-i9	i10-i13	i14-i16	i17-i20	i21-i23	i24	i25-i26
SC_i (\$)	87.4	15.0	715.2	575	312	1018.9	2298	0
MPC_i (\$)	5.2	5.0	7.5	8.5	6.2	15.0	20.0	0
$C_{i,t,1}^{G-Eng}$ (\$/MWh)	23.4	29.6	11.5	18.6	9.9	19.2	10.1	5.3
$C_{i,t,2}^{G-Eng}$ (\$/MWh)	23.8	30.4	12.0	20	10.2	20.3	10.7	5.4
$C_{i,t,3}^{G-Eng}$ (\$/MWh)	26.8	42.8	13.9	21.9	10.7	21.2	11.1	5.5
$C_{i,t,4}^{G-Eng}$ (\$/MWh)	30.4	43.3	15.9	22.7	11.3	22.1	11.7	5.7

The system load curve is divided into three periods such that the hours between 1:00 and 8:00 are considered as valley period. The hours 9:00 to 16:00 are off-peak period. The hours between 17:00 and 24:00 are peak period, while the hours 17:00 to 18:00 denote critical peak period.

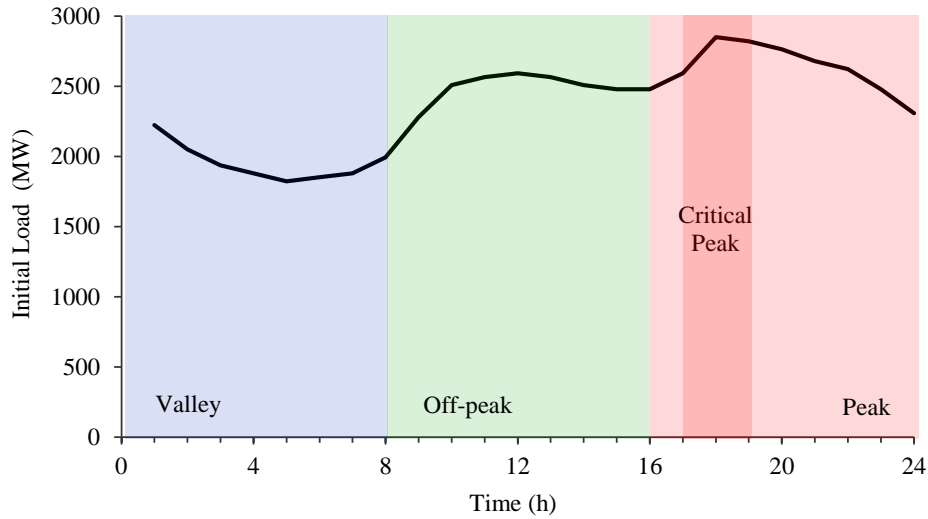

Fig. 1. Hourly initial load curve

As mentioned before, four DR programs including TOU, RTP, CPP, and EDRP are considered as stated in Table 2. Note that the TOU program is easy to implement with existing digital meters. The other programs such as RTP, CPP, and EDRP need smart metering infrastructures which are achievable due to the fact that the smart meters are developing all over the world.

Table 2. Statements of DR programs

DR Type	Programs	Electricity price (\$/MWh)	Incentive value at peak (\$/MWh)
Base	Initial load	16 flat rate	0
Tariff-based	TOU	8, 16, 21.5 at valley, off-peak, and peak periods, respectively	0
	RTP	12,10.7,7.2,7.7,10.4,10.4,10.5,10.7,11.1,13.9,15,20.3,20.3,20.1,20.3,19.1,20.6,22.1,22.1,22.1,	0

		21.9,21.2,20.3,13.9 at 1-24h	
	CPP	44 at critical peak period and otherwise 16	0
Incentive-based	EDRP	16 flat rate	7

The values of customer's price elasticity of demand are extracted from [31] as shown in Table 3. The elasticity matrix is in fact a 24×24 matrix includes both cross and self elasticity values. Note that the diagonal elements are self elasticities which are negative numbers, while the off-diagonal elements are cross elasticities which have positive values.

Table 3. Price elasticity values [31]

	Peak	Off-peak	Valley
Peak	-0.10	0.016	0.012
Off-peak	0.016	-0.10	0.010
Valley	0.012	0.010	-0.10

It is noteworthy that although implementation of DR in a large area is difficult in the real world, however, the proposed framework can provide a guideline for power system operators to choose more efficient DR strategies at different load buses according to economic considerations, network conditions, customer's participation rate and demand elasticity. The proposed model was solved using CPLEX 12.5.0 on an Intel Core i5-2410 computer at 2.3 GHz and 4 GB of RAM under General Algebraic Modeling System (GAMS) software. In order to evaluate the effectiveness of the proposed model, several case studies have been carried out and the obtained results are discussed in the following sub-sections.

4.1. Optimal allocation of DR programs

The optimal location of DR implementation regardless the type of DR program has been determined in two different manners. In the first case, similar elasticity values are assumed for all the load buses as mentioned in Table 3, while the customers are classified into three categories based on their elasticity values in the second case. For this purpose, the price elasticity values of Table 3 are multiplied by coefficients 0.5, 1, and 1.5, respectively. In order to find the priority of load buses for implementing DR, N^{DR} in Eq. (8) which specifies the permissible number of load buses for DR implementation is changed from 1 to 17 step by step and the priority of load buses are determined as shown in Fig. 2 for both the considered case studies.

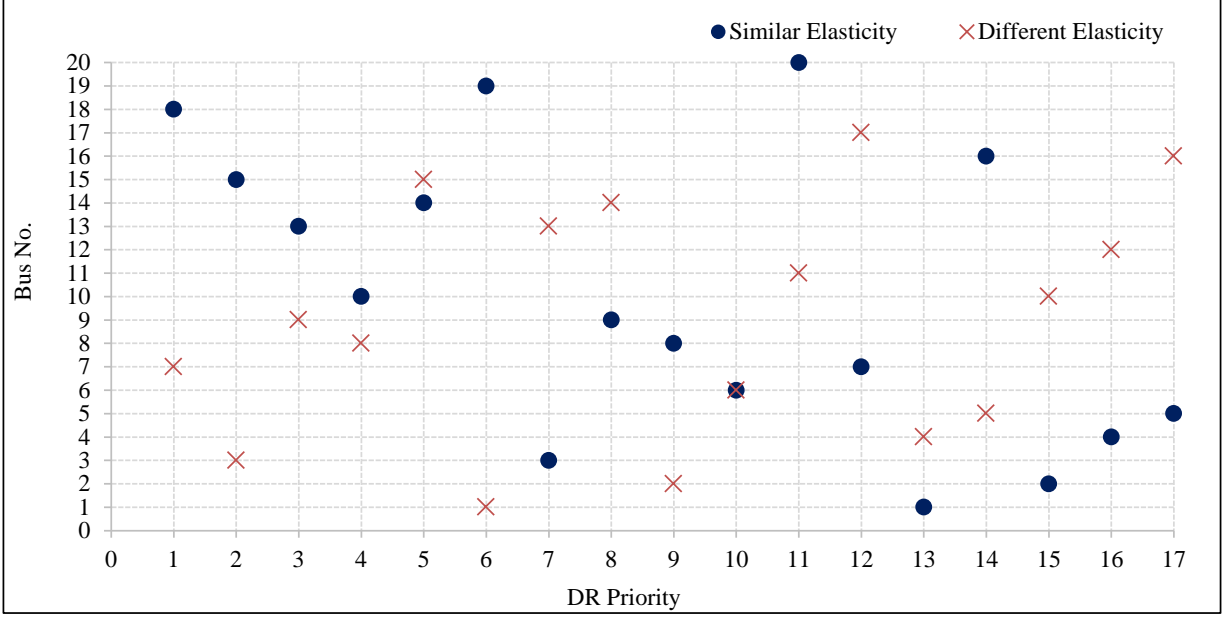

Fig. 2. DR implementation priority in the given cases

According to Fig. 2, the load buses which have higher amounts of network demand are selected as the most suitable locations when all the load buses are considered to have similar elasticity values. For instance, the load buses 18, 15, 13, 10, 14, and 19 have the highest priority in the first case which constitute 11.7%, 11.1%, 9.3%, 6.8%, 6.8%, and 6.4% of daily peak demand, respectively.

In the second case, it is presumed that the elasticity of customers at load buses 7, 1, 16, 2, 4, and 5 be 1.5 times greater than the mentioned values of Table 3, while the elasticity of customers at load buses 18, 15, 13, 10, 14, and 19 are considered to be half of the values of Table 3. In fact, it is supposed that the large consumers have less sensitivity to electricity tariffs changes or incentive payments. The obtained results reveal that the customer's elasticity has a significant impact on DR allocation. In this situation, the load buses 7, 3, 9, 8, 15, and 1 are selected as the most suitable candidates. Therefore, it can be concluded that the accurate allocation of DR needs a compromise between the elasticity of customers and their share in peak load.

4.2. Optimal mixture of DR programs

Solving the proposed DR optimization problem not only determines the optimal location of DR implementing, but also specifies the most efficient mixture of DR at each load bus in terms of type of DR program and its particular penetration rate. The optimal DR mixture in the selected load buses is demonstrated in Fig. 3 in the case of customers with different elasticity values when N^{DR} is set to 5. It is noticed that Fig. 3(a) and Fig. 3(b) associated with 20% and 30% total responsiveness rate, respectively.

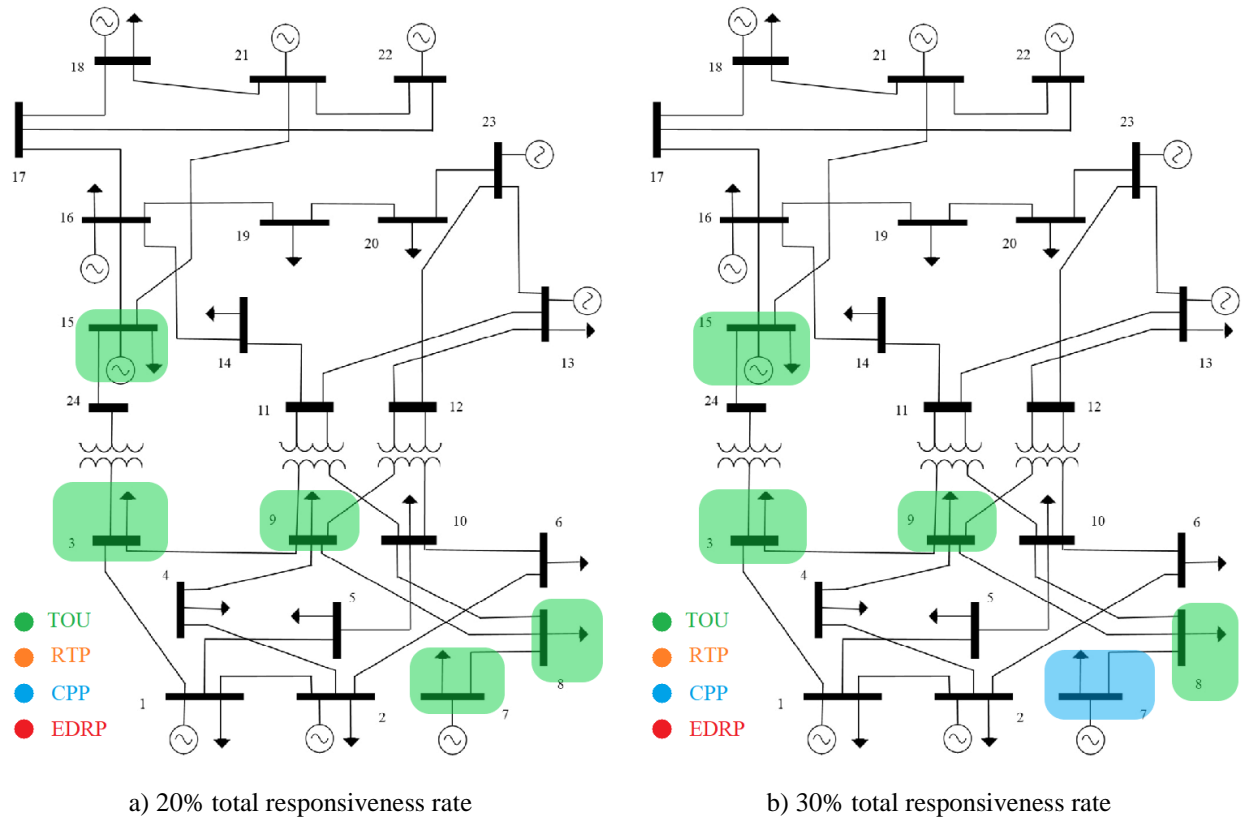
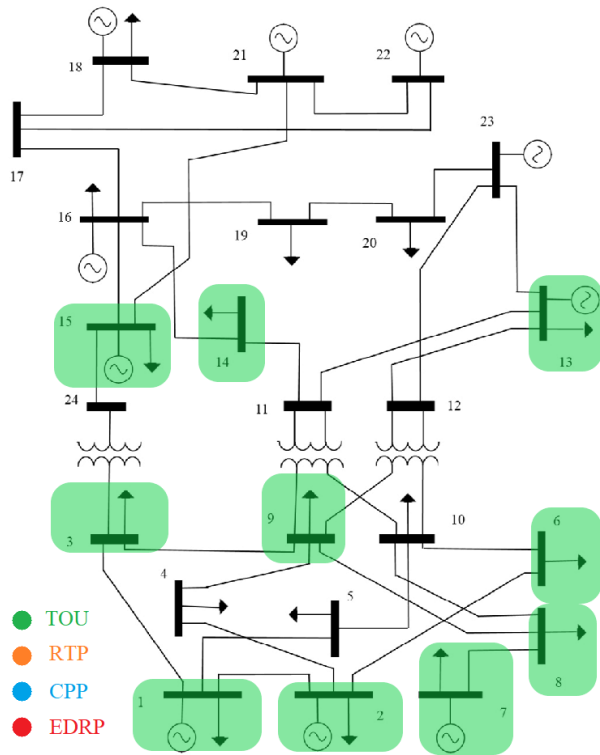

Fig. 3. Optimal mixture of DR programs when N^{DR} is set to 5

According to Fig. 3, at both responsiveness levels similar load buses have been selected for DR implementation. Moreover, TOU is the most prevailing DR program in this case. Note that, the optimal DR program at load bus 7 is changed from TOU to CPP by increasing the responsiveness level from 20% to 30%.

The DR optimization problem has been solved for different responsiveness rates taking into account $N^{DR}=10$. Note that, the percentage of consumers respond to price is an uncertain parameter depends on many factors such as social acceptance of DR, regulatory rules, developments related to grid modernization and advanced metering. Therefore, several numerical analysis considering a wide range for customer's participation rate have been performed as illustrated in Fig. 4.



a) 10% total responsiveness rate

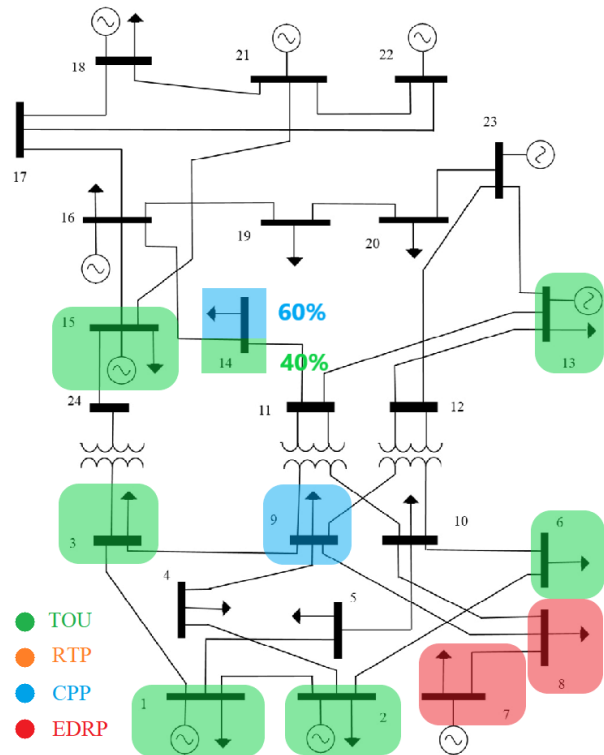

b) 20% total responsiveness rate

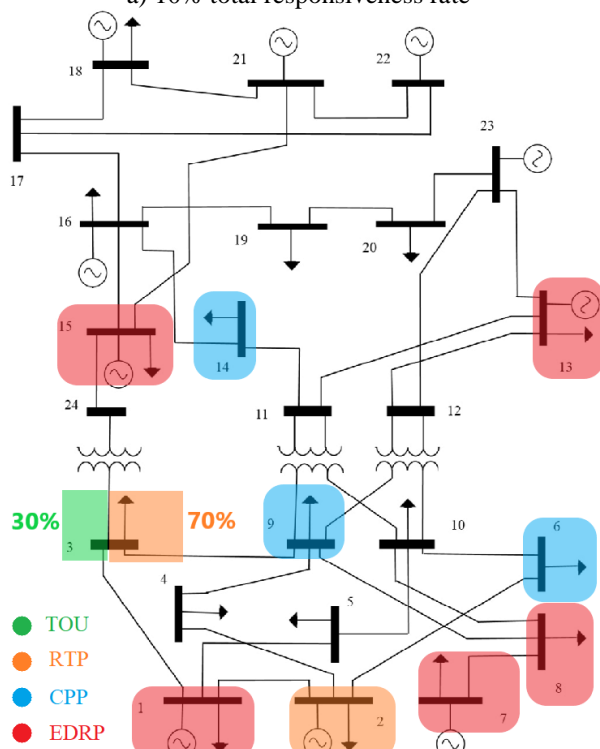

c) 30% total responsiveness rate

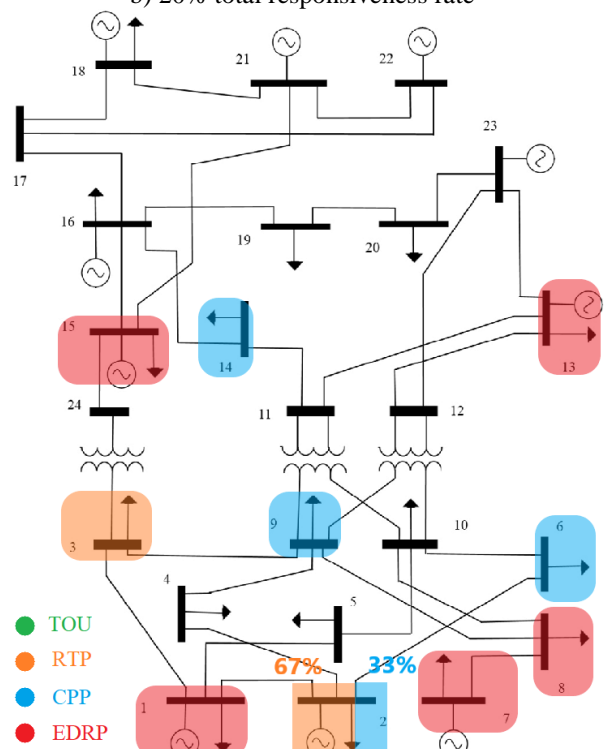

d) 40% total responsiveness rate

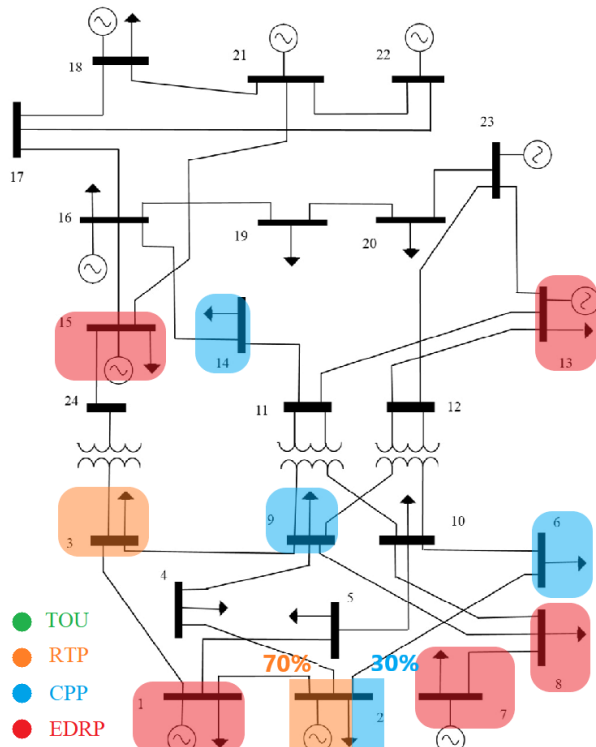

e) 50% total responsiveness rate

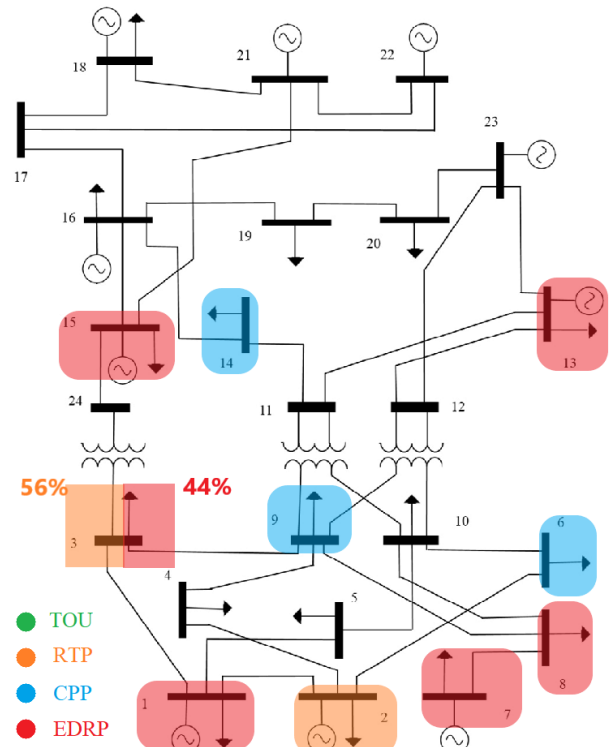

f) 60% total responsiveness rate

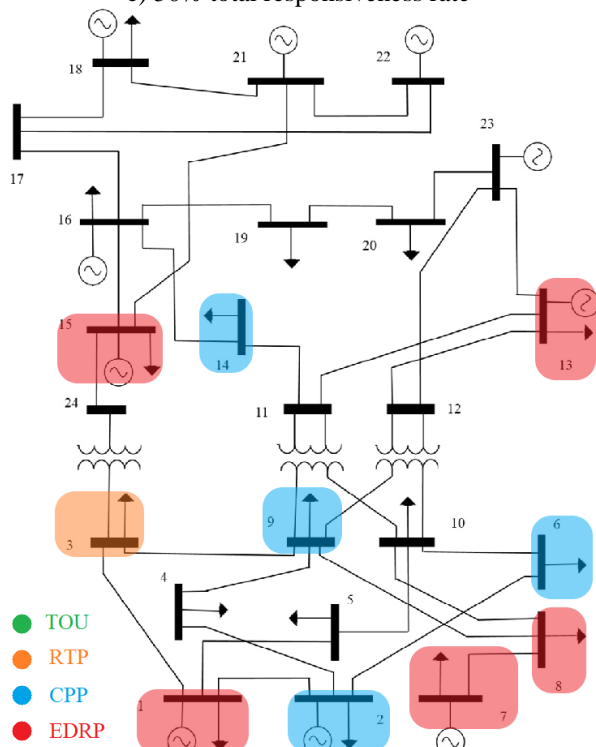

g) 70% total responsiveness rate

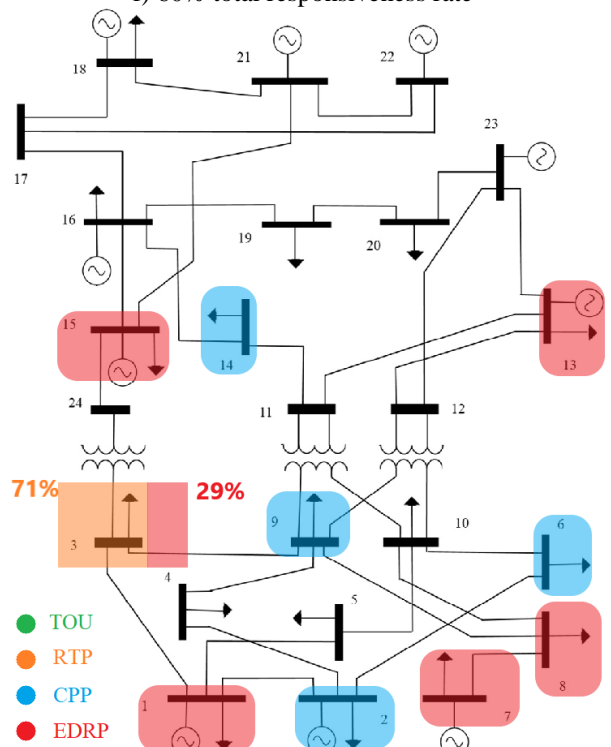

h) 80% total responsiveness rate

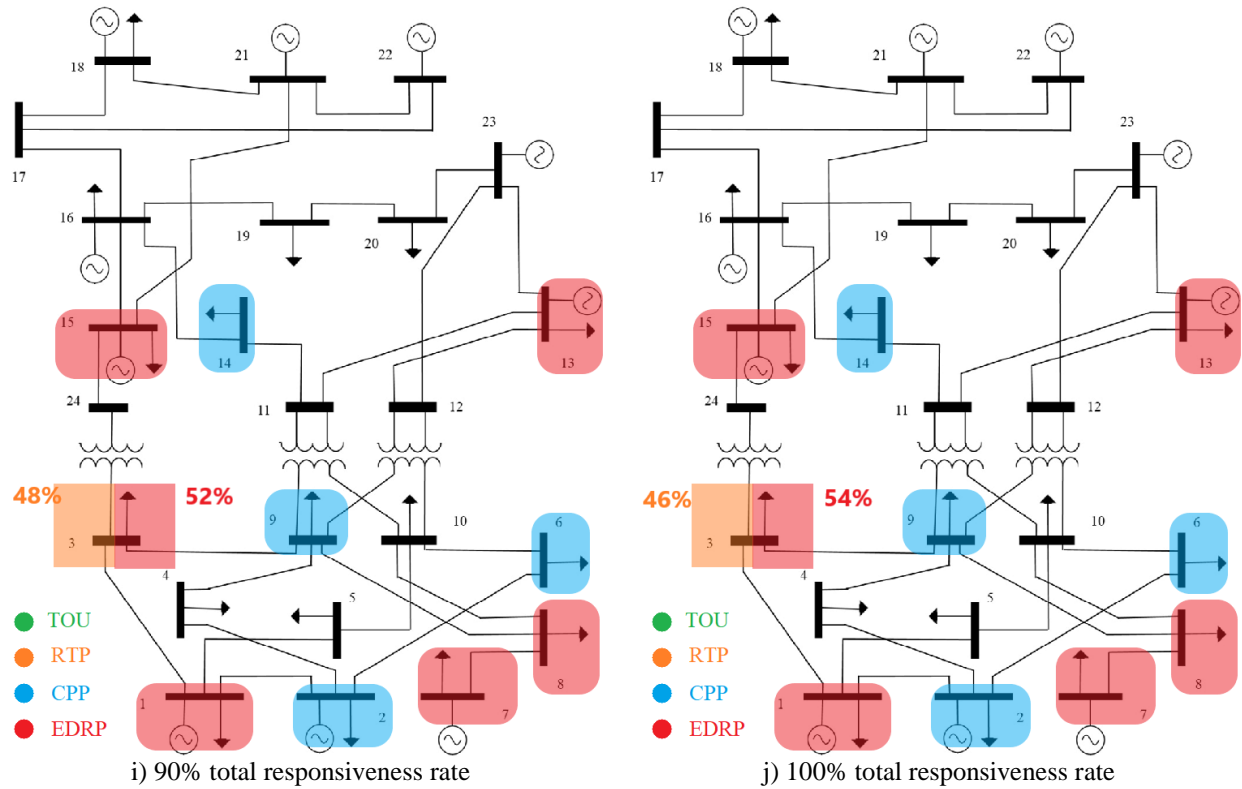

Fig. 4. Optimal mixture of DR programs when N^{DR} is set to 10

As observed, when the total responsiveness rate is 10%, the TOU program is the most effective DR at all the ten load points. By increasing the responsiveness rate from 10% to 20%, the TOU, CPP, and EDRP are selected as the most effective DR programs while the share of TOU is dominant in most of the load buses. According to Fig. 4(b), exclusive implementation of TOU is the optimal solution for load buses 1, 2, 3, 6, 13, and 15. The EDRP is selected as the only effective DR program for load buses 7 and 8, while the CPP program is designated for load bus 9. It is noteworthy that the optimal DR scheme at load bus 14 includes both the TOU and CPP programs with 40% and 60% shares, respectively. It is obvious that the share of TOU program has a remarkable reduction when the total responsiveness rate increases to 30% and higher values due to Fig. 4(c). In particular, the TOU program at load buses 1, 13, and 15 is substituted with EDRP and the TOU is replaced with CPP at load bus 6. Moreover, the role of RTP will be more highlighted as it can be observed at load buses 2 and 3. When the responsiveness rate increases to 40%, just the DR mixture at load buses 2 and 3 changes as indicated in Fig. 4(d). For instance, the share of RTP is enhanced to 100% at load bus 3, while the share of RTP at load bus 2 has been decreased to 67%.

For responsiveness rates higher than 70%, just the DR mixture at load bus 3 changes. As observed, the share of RTP program at load bus 3 gradually begins to decline by increasing the responsiveness rate from 70% to 100%. In such

a situation, the share of EDRP is increased at the mentioned load bus from 0 to 54% when the network load is considered to be completely elastic.

4.3. Economic Evaluation of DR optimization scheme

The total system operating costs under different DR programs have been reported in Table 4 considering total responsiveness rates of 20% and 30%, respectively. Note that ten buses are allowed to participate in DR programs that have different elasticity as mentioned before in Section 4.1. As presented in Table 4, when no DR program is implemented, the operating cost is 605481\$. Implementing the proposed DR scheme can reduce the operation cost about 10539\$ and 14106\$ per day when the total responsiveness rate is 20% and 30%, separately. It is obvious that cost saving as a consequence of implementing the proposed DR scheme is more in comparison with the other programs, particularly when the customer’s participation rate is limited to 20%. On this basis, it can be concluded that the proposed DR scheme is more effective especially when customer’s participation level is relatively limited. It is noteworthy that the operation cost in the case of EDRP is relatively higher according to the required incentive payments.

Table 4. Comparison of operation cost in different DR programs

<u>DR program</u>	<u>Total responsiveness rate (%)</u>	<u>Operation cost (\$)</u>
No DR	-	605481
MIX	20	594942
	30	591375
TOU	20	596066
	30	592939
RTP	20	596219
	30	592914
CPP	20	596013
	30	592024
EDRP	20	597413
	30	593325

As observed, different DR programs have their own special impact on the system operation cost due to the fact that they change the initial load curve in different ways. The modified load curves as a result of implementing different DR programs have been represented in Fig. 5.

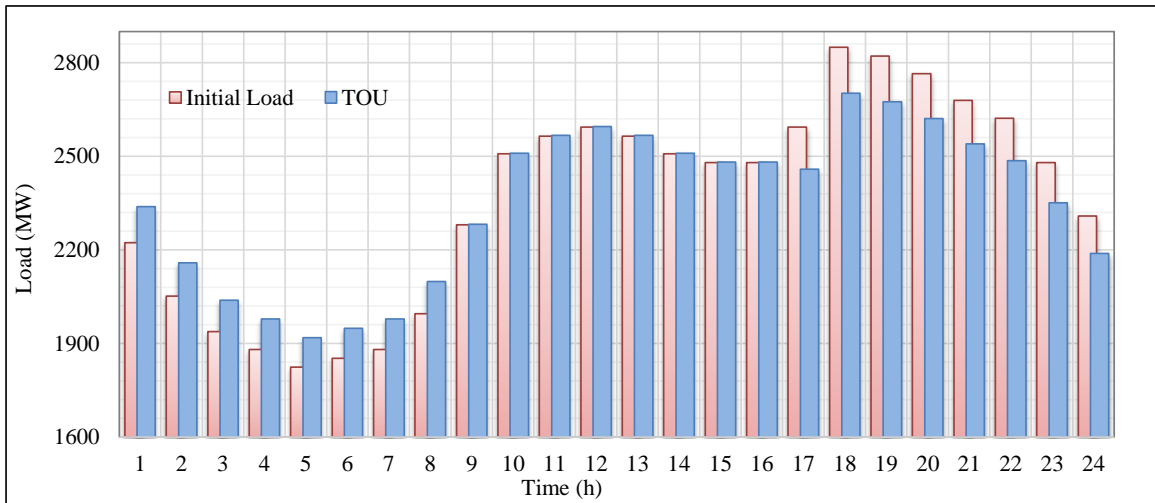

a) TOU

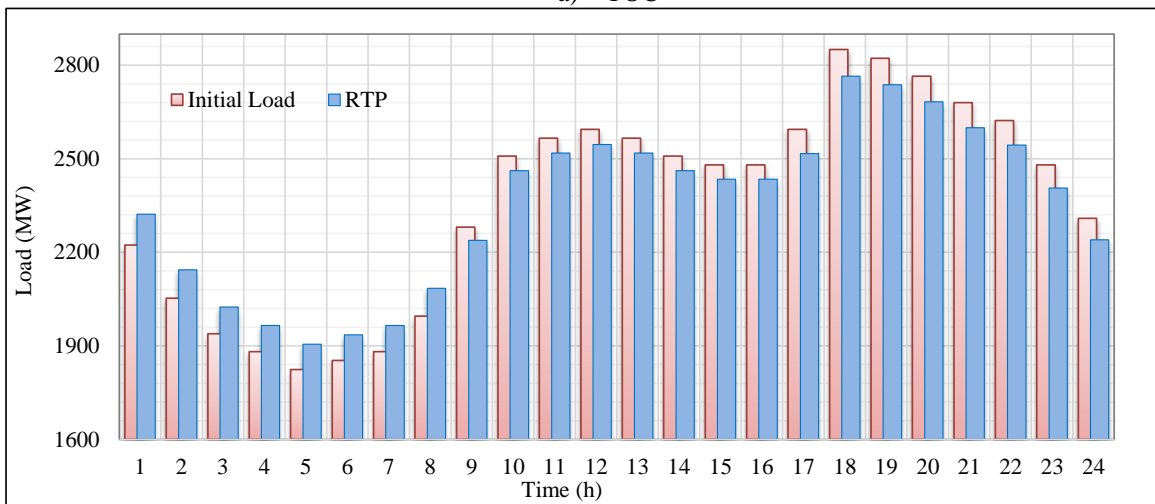

b) RTP

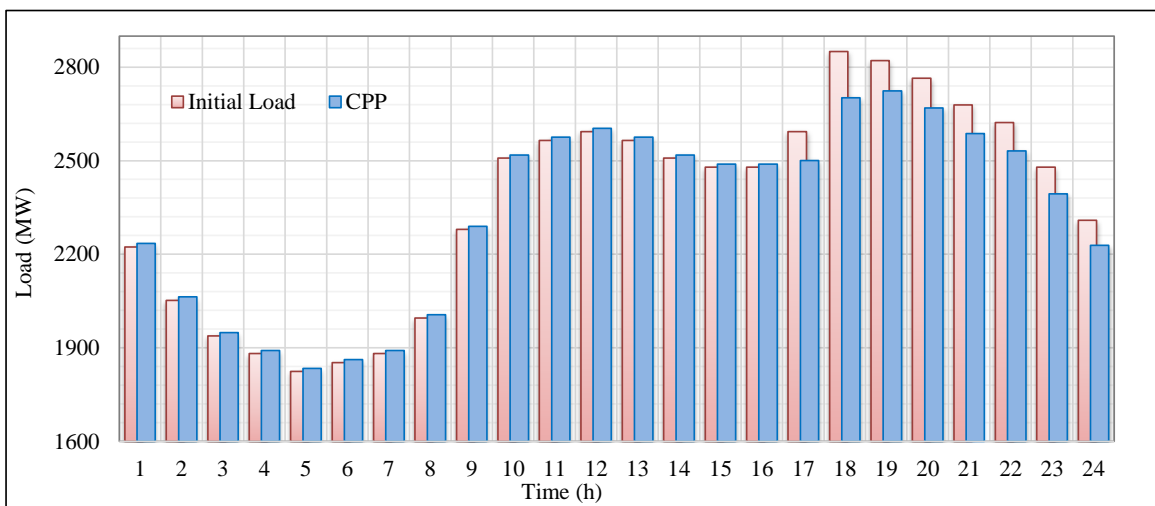

c) CPP

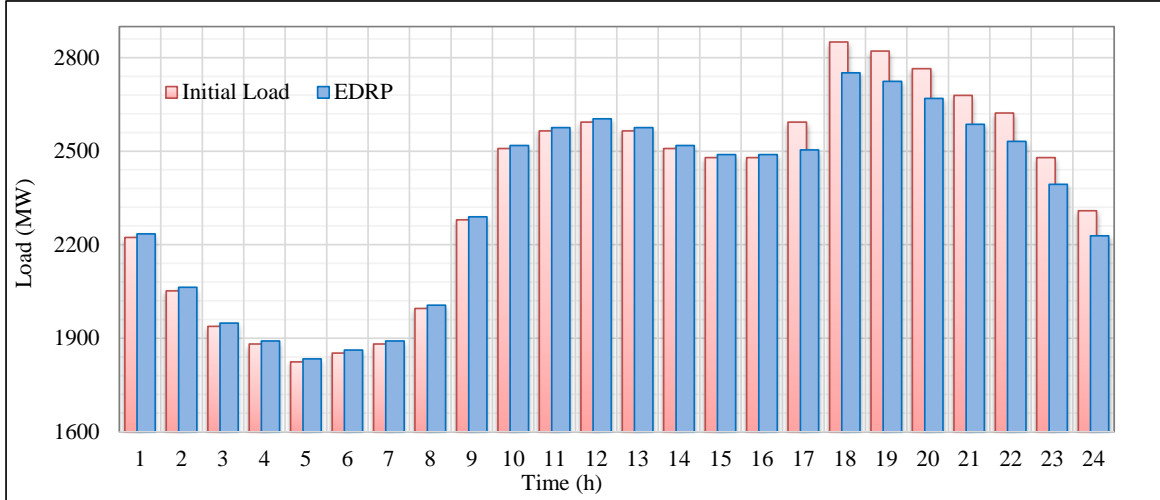

d) EDRP

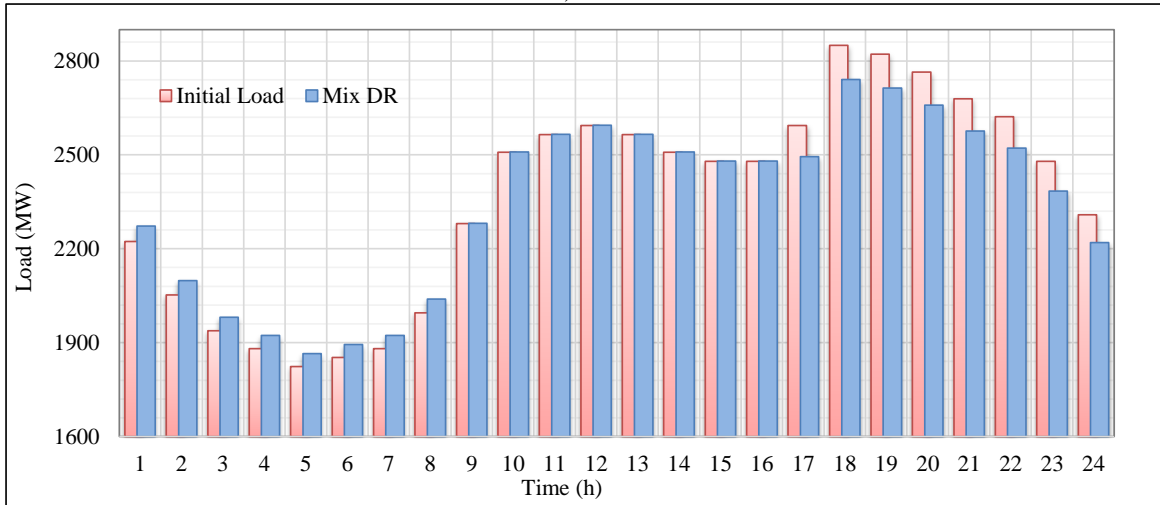

e) Mix DR

Fig. 5. Impact of given DR programs on the initial load curve

As shown in Fig. 5, the TOU and RTP programs transfer some consumptions from the peak period to the valley period. By comparing Fig. 5(a) and Fig. 5(b), it can be seen that the consumption in the off-peak period also has a slight reduction in the case of RTP and the valley filling is less. According to Fig. 5, it is obvious that the CPP and EDRP mostly try to reduce the peak instead of shift the consumption due to their inherent natures. However, as illustrated, the proposed DR mixture not only persuades the customers to shift their consumption to the valley period, but also reduces the peak load, simultaneously.

5. Conclusions

This paper presented a novel linear DR optimization model that incorporated into the network-constrained unit commitment problem. The proposed model determines the optimal bus of implementing DR and identifies the optimal type of DR program at each load bus. Some practical limits on DR implementation were considered such as a limited number of load bus candidates and different price-demand elasticities of customers, and impact of the penetration rate of DR programs was also investigated. The numerical results proved that the key factors to find the optimal location or bus for implementing DR were the price-demand elasticity of customers and the proportion of customers' demand at the system peak. The results showed when the total responsiveness rate of the customers was low, TOU was the best DR program. When the total responsiveness rate of the customers was high, the CPP and EDRP were the best programs. Moreover, the numerical results revealed when the customer's participation level was limited, the proposed mixture of DR programs could have a remarkable impact on cost-saving. The proposed DR mixture could also improve the whole system load profile by motivating the customers to shift their consumption to the valley period and reducing the peak load.

Acknowledgments

The work of E. Heydarian-Forushani and M. E. H. Golshan was supported by Iran National Science Foundation (INSF) under grant agreement no. 96017036.

References

- [1] Jordehi AR. Optimisation of demand response in electric power systems, a review. *Renewable and Sustainable Energy Reviews* 2019; 103:308-319.
- [2] Heydarian-Forushani E, Moghaddam MP, Sheikh-El-Eslami MK, Shafie-Khah M, Catalão JPS. A stochastic framework for the grid integration of wind power using flexible load approach. *Energy conversion and management* 2014; 88:985-998.
- [3] Heydarian-Forushani E, Golshan MEH, Shafie-khah M. Flexible security-constrained scheduling of wind power enabling time of use pricing scheme. *Energy* 2015; 90:1887-1900.
- [4] Nan S, Zhou M, Li G. Optimal residential community demand response scheduling in smart grid. *Applied Energy* 2018; 210:1280–1289.

- [5] Alipour M, Zare K, Abapour M. MINLP probabilistic scheduling model for demand response programs integrated energy hubs. *IEEE Transactions on Industrial Informatics* 2017; 14(1): 79-88.
- [6] Nwulu NI, Xia X. Optimal dispatch for a microgrid incorporating renewables and demand response. *Renewable Energy* 2017; 101:16–28.
- [7] Alirezazadeh A, Rashidinejad M, Abdollahi A, Afzali P, Bakhshai A. A new flexible model for generation scheduling in a smart grid. *Energy* 2020; 191:116438.
- [8] Aalami HA, Pashaei-Didani H, Nojavan S. Deriving nonlinear models for incentive-based demand response programs. *International Journal of Electrical Power & Energy Systems* 2019; 106: 223-231.
- [9] Aalami HA, Moghaddam MP, Yousefi GR. Evaluation of nonlinear models for time-based rates demand response programs. *International Journal of Electrical Power & Energy Systems* 2015; 65: 282-290.
- [10] Abdulaal A, Moghaddass R, Asfour S. Two-stage discrete-continuous multi-objective load optimization: an industrial consumer utility approach to demand response. *Applied Energy* 2017; 206:206–221.
- [11] Hu M, Xiao F. Price-responsive model-based optimal demand response control of inverter air conditioners using genetic algorithm. *Applied Energy* 2018; 219:151–164.
- [12] Qian LP, Zhang YJA, Huang J, Wu Y. Demand response management via real-time electricity price control in smart grids. *IEEE Journal on Selected areas in Communications* 2013; 31(7): 1268-1280.
- [13] Derakhshan G, Shayanfar HA, Kazemi A. The optimization of demand response programs in smart grids. *Energy Policy* 2016; 94:295–306.
- [14] Hassan MAS, Chen M, Lin H, Ahmed MH, Khan MZ, Chughtai GR. Optimization modeling for dynamic price based demand response in microgrids. *Journal of cleaner production* 2019; 222: 231-241.
- [15] Zhou S, Zou F, Wu Z, Gu W, Hong Q, Booth C. A smart community energy management scheme considering user dominated demand side response and P2P trading. *International Journal of Electrical Power & Energy Systems* 2020; 114: 105378.
- [16] Ajoulabadi A, Ravadanegh SN, Mohammadi-Ivatloo B. Flexible scheduling of reconfigurable microgrid-based distribution networks considering demand response program. *Energy* 2020; 196: 117024.
- [17] Chen Y, Chen Z, Xu P, Li W, Sha H, Yang Z, Hu C. Quantification of electricity flexibility in demand response: Office building case study. *Energy* 2019; 188: 116054.

- [18] Roos A, Bolkesjø TF. Value of demand flexibility on spot and reserve electricity markets in future power system with increased shares of variable renewable energy. *Energy* 2018; 144: 207-217.
- [19] Kühnlenz F, Nardelli PH, Karhinen S, Svento R. Implementing flexible demand: Real-time price vs. market integration. *Energy* 2018; 149: 550-565.
- [20] Ma J, Venkatesh B. A new measure to evaluate demand response effectiveness and its optimization. *Electric Power Systems Research* 2020; 182: 106257.
- [21] Neves D, Pina A, Silva CA. Comparison of different demand response optimization goals on an isolated microgrid. *Sustainable Energy Technologies and Assessments* 2018; 30: 209-215.
- [22] Jahani MTG, Nazarian P, Safari A, Haghifam AMR. Multi-objective optimization model for optimal reconfiguration of distribution networks with demand response services. *Sustainable Cities and Society* 2019; 47: 101514.
- [23] Namerikawa T, Okubo N, Sato R, Okawa Y, Ono M. Real-time pricing mechanism for electricity market with built-in incentive for participation. *IEEE Transactions on Smart Grid* 2015; 6(6): 2714-2724.
- [24] He Y, Zhang J. Real-time electricity pricing mechanism in China based on system dynamics. *Energy conversion and management* 2015; 94: 394-405.
- [25] Chao HP. Efficient pricing and investment in electricity markets with intermittent resources. *Energy Policy* 2011; 39(7): 3945-3953.
- [26] Philip Mosenthal JL. Guide for Conducting Energy Efficiency Potential Studies. Department of Energy and U.S. Environmental Protection Agency in their capacity as co-sponsors for the National Action Plan for Energy Efficiency 2007.
- [27] Siddiqui O. Assessment of Achievable Potential from Energy Efficiency and Demand Response Programs in the U.S. (2010-2030), Electric Power Research Institute, 2009.
- [28] Baboli PT, Moghaddam MP. Allocation of network-driven load-management measures using multi attribute decision making. *IEEE Transactions on Power Delivery* 2010; 25(3):1839-1845.
- [29] Aghaei J, Alizadeh MI, Abdollahi A, Barani M. Allocation of demand response resources: toward an effective contribution to power system voltage stability. *IET Generation, Transmission & Distribution* 2016; 10(16): 4169-4177.

- [30] U. S. Department of Energy, "Benefits of Demand Response in electricity markets and Recommendations for achieving them", section 1252 of the report, " Energy policy Act of 2005", February 2006.
- [31] Aalami HA, Moghaddam MP, Yousefi GR. Modeling and prioritizing demand response programs in power markets. *Electric Power System Research* 2010; 80:426–435.
- [32] Abdollahi A, Moghaddam MP, Rashidinejad M, Sheikh-El-Eslami MK. Investigation of economic and environmental-driven demand response measures incorporating UC. *IEEE transactions on smart grid* 2011; 3(1):12-25.
- [33] Reliability Test System Task Force. The IEEE reliability test system – 1996. *IEEE Trans. Power Syst.*, vol. 14, no. 3, pp. 1010-1020, 1999.