



Vaasan yliopisto
UNIVERSITY OF VAASA

OSUVA Open
Science

This is a self-archived – parallel published version of this article in the publication archive of the University of Vaasa. It might differ from the original.

Active network management scheme for reactive power control

Author(s): Sirviö, Katja; Laaksonen, Hannu; Kauhaniemi, Kimmo

Title: Active network management scheme for reactive power control

Year: 2018

Version: Publisher's PDF

Copyright ©2018 International Conference and Exhibition on Electricity Distribution CIRED

Please cite the original version:

Sirviö, K., Laaksonen, H., & Kauhaniemi, K., (2018). Active network management scheme for reactive power control. In: *CIRED Workshop Proceedings : Microgrids and Local Energy Communities, Ljubljana, Slovenia, June 7-8, 2018*, paper 0080. <https://www.cired-repository.org/handle/20.500.12455/1099>

ACTIVE NETWORK MANAGEMENT SCHEME FOR REACTIVE POWER CONTROL

Katja SIRVIÖ
University of Vaasa – Finland
katja.sirvio@uva.fi

Hannu LAAKSONEN
University of Vaasa – Finland
hannu.laaksonen@uva.fi

Kimmo KAUHANIEMI
University of Vaasa – Finland
kimmo.kauhaniemi@uva.fi

ABSTRACT

In the future new options to provide needed technical ancillary services locally and system-wide by distributed energy resources (DER) are needed. One ancillary service which DER could provide is the reactive power management when microgrid is operated in utility grid-connected mode. In this paper different requirements for reactive power flow between distribution and transmission grids were considered in Sundom Smart Grid (SSG) and the measured data from SSG was used for developing a concept for reactive power management. Based on these different requirements “Future Reactive Power Window” was formulated for SSG which was the basis for control scheme formulation. The simulations showed that coordinated reactive power management across different voltage levels by utilizing control of distributed generation could be very beneficial to the voltage support ancillary service.

INTRODUCTION

Due to extensive integration of distributed generation (DG) units different options to provide needed technical ancillary services locally and system-wide are needed in future Smart Grids. Solutions for the coordinated management of ancillary services across different voltage levels and for the benefit of different stakeholders has yet to be studied [1]–[3]. Sundom Smart Grid, Innovation Cell Finland in DeCAS project¹, offers a novel platform for the development of ancillary service solutions for future grids across different voltage levels.

Different requirements for reactive power flow have been studied in this paper. EU sets grid code requirements. Further local transmission system operator (TSO), Fingrid set requirements for reactive power flow by “Reactive Power Window”. In addition, reliable and islanding detection and possibility to make stable transition to island operation set requirements for control of reactive power flow.

Reactive power flow across different voltage levels was studied in this paper. First the SSG and the requirements

for the reactive power management are presented. Thereafter the simulation model is described and the study cases are presented. Finally, conclusions and future research questions are presented.

SUNDOM SMART GRID

Sundom Smart Grid is the innovation cell of Finland in DeCAS project. Sundom Smart Grid is a pilot living lab of ABB, Vaasan Sähköverkko (Distribution System Operator, DSO), Elisa (communications) and University of Vaasa [4]. The overview of the system is presented in Figure 1. Real-time measurements are gathered from the MV distribution network on-line, from all four feeders at one HV/MV substation as well as from three MV/LV sub-stations. There is 20 measurement points totally in Sundom Smart Grid. The measured data is IEC61850 stream (IEEE1588 time synchronized, IEC61850-9-2) with current and voltage measurements. The sampling is 80 samples per a cycle, which is 4000 samples/s. In addition power, frequency, RMS voltages, currents etc. measurements comes by GOOSE messages. Measured data is collected to servers to provide data also for future research themes. In this project the data was received and utilised via Grafana web interface developed by Jubic. The data attributes downloaded were instMag.f (GOOSE-type) from the selected measurement points.

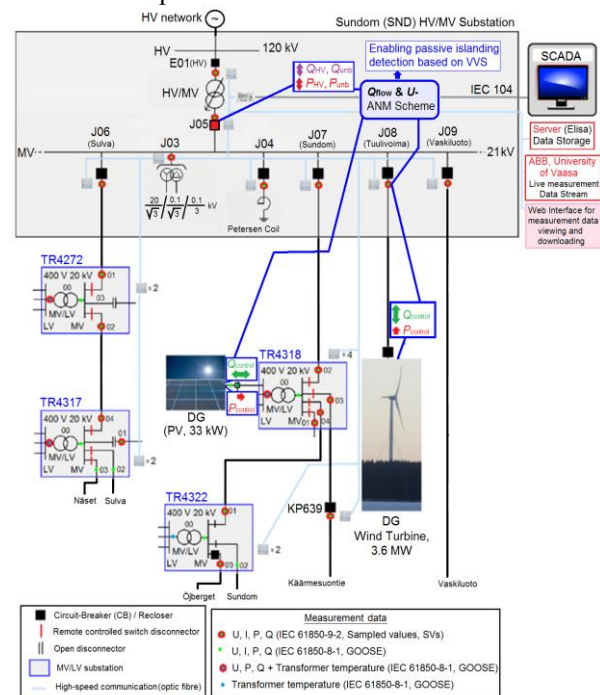

Fig. 1. One-line diagram of Sundom Smart Grid living lab.

¹ This work was carried out in Demonstration of Coordinated Ancillary Services (DeCAS) research project coordinated by (<http://www.decas-project.eu>). This project has received funding in the framework of the joint programming initiative ERA-Net Smart Grids Plus, with support from the EU’s Horizon 2020 research and innovation program.

PRINCIPLES FOR REACTIVE POWER MANAGEMENT OF FUTURE SUNDOM SMART GRID

Reactive power management for SSG should be observed by the present conditions set by Finnish TSO, Fingrid, which entered into force beginning of 2017. Reactive power window gives the limits for the hourly consumed or produced reactive power regarding to consumed or produced active power (Q_i, P_i) without fees. Exceeding points (Q_m, P_m) are billed, which is illustrated in Figure 2.[5]

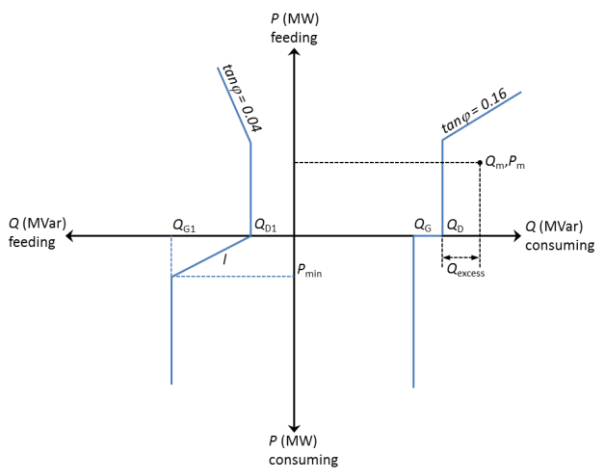

Fig. 2. Fingrid's reactive power window. Applied from [5].

In future, when considering microgrids the requirements for reliable islanding detection should be taken into account. Active and reactive power flows should be managed the way they don't reach Non Detecting Zone (NDZ). On the same principle a zone for stable transition to intended island operation has to be adopted. [6] – [8]

In addition, if the requirements for new installations need to be considered, the Network Code of Demand Connection sets requirements of reactive power management for the transmission connected distribution systems. Reactive power should not exceed 48 % of maximum capacity to import or export of active power (P_{max}). TSO may also require that it is not allowed to export reactive power in the situation where reactive power import is below $0.25P_{max}$. [9]

Figure 3 presents and combines TSO and microgrid requirements as active and reactive power operation limits for future SSG, also the EU requirements for demand connection are illustrated on the background. Limits for the maximum active power is based on the measured data the year 2016, when $P_{max,import}$ was 8.3 MW and $P_{max,export}$ was 1.975 MW. Limits a for reliable islanding detection as well as limit b for stable transition to island operation was implemented based on simulations [10].

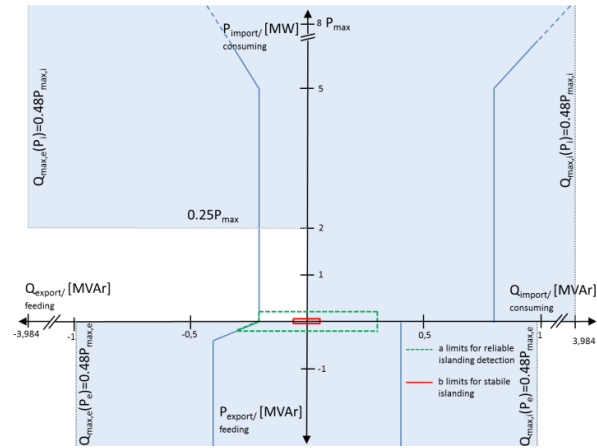

Fig. 3. Active and reactive power operation limits for future SSG.

SIMULATION MODEL

The simulation model of SSG was created with Matlab/SimscapePowerSystems. The model is developed from “One-Year Simulation in One Minute” model [11], which simulates one year P and Q flow based on hourly data. The main grid was modelled as a three-phase source with phase-to-phase voltage of 134.585 kV (the highest voltage based on primary transformer tap positions). U_n of the primary transformer was 117/21 kV and S_n was 16 MVA. On load tap changer (OLTC) was not modelled because using an OLTC model of a transformer caused the simulation speed to slow down too much.

Four feeders were modelled, where three of them J06, J07 and J09 load profiles were generated from the real system measurements. The data was diffused and available only for some months, so the consumption data model was generated based on the data in May 2017 and using “Typical load profiles” (TLP) [12] to extend it for the whole year. One feeder, J08, was solely for 3.6 MW wind turbine. The wind turbine was 3.6 MW PMG synchronous generator type and the converter was a full power IGBT type [13]. Wind data was generated by combining data from Klemettilä weather station [14] near Sundom and data available from Tuuliatlas [15].

One distribution transformer TR4318 and its LV network were modelled including a 33.6 kWp PV system. Solar irradiation data was generated from classic database of Photovoltaic Geographical Information System (PVGIS) [16], which was obtained hourly profiles of solar irradiance estimates on a fixed plane [W/m^2].

STUDY CASES

In Basic Case the present situation of the reactive power flow in the Sundom Smart Grid was presented. Power factor of the WG converter was set 0.97_{ind} based on the measurements May 2017. The reactive power window at TSO (110 kV) side is presented in Fig. 4. The “reactive power window” at DSO (21 kV) side was ~ 70 kVAr more consuming because of the effect of the primary transformer inductance.

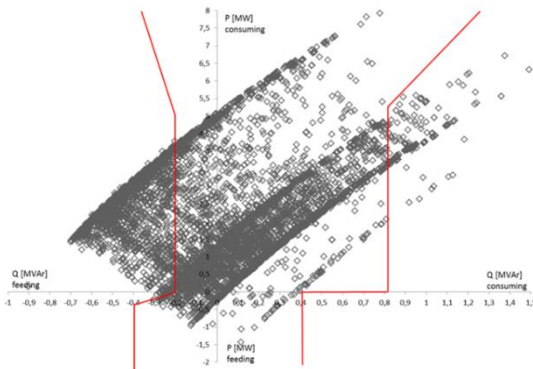

Fig. 4. Reactive power window at 110 kV side in Basic Case.

In Microgrid Case the TSO’s requirements of reactive power window and in addition, NDZ requirement of $Q \pm 50$ kVAr to enable islanding detection was studied. In this case the idea was to develop a control algorithm for wind turbine converter. The developed algorithm is presented in Fig. 5. The action was check if (Q_i, P_i) were out of the window at the primary transformer primary side or in the NDZ area at the primary transformer secondary side. If the point was out of the window, the algorithm drove $Q_{set} = \pm 50$ kVAr depending on the direction. If the point was in the NDZ, the algorithm drove $Q_{set} = Q_i \pm 50$ kVAr depending on the direction of Q_i . If the point was inside the window and out of NDZ no control action was done. The reactive power window is presented in Fig. 6.

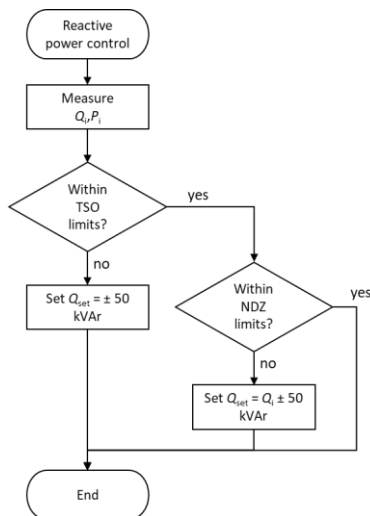

Fig. 5. Control algorithm for reactive power control in Microgrid Case.

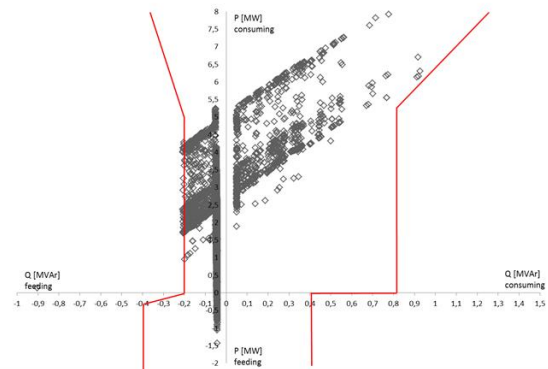

Fig. 6. Reactive power window in Microgrid Case.

CONCLUSIONS

Based on the simulations the reactive power management in SSG could be implemented by controlling the converter of the WG unit. In future when cabling degree will increase the adequacy of the converter reactive power consumption capability should be investigated. In addition if the amount of photovoltaics (PV) would increase, the possibility to utilize PV inverters for reactive power management should be studied.

Considering the requirements for microgrids and the reliable islanding detection by reactive power management, the control algorithm for reactive power of the WG converter was developed. In addition the means of active power control should be studied, which could be developed by means of an energy storage system, by demand response actions or by limiting distributed power generation.

The simulation model can be developed further for the future studies. By implementing one year measured data (consumption and power generation) to the model more accurate model would be obtained. For control studies of the technical ancillary services a shorter period of time with the measured data could be implemented.

REFERENCES

- [1] K. Kosovinc, 2017, "Volt/var Control", Literature Research, *Technical Report of DeCAS Research Program*, Vienna.
- [2] M. Tahir, M. E. Nassar, R. El-Shatshat and M. M. A. Salama, 2016, "A review of Volt/Var control techniques in passive and active power distribution networks," *Proceedings IEEE Smart Energy Grid Engineering (SEGE)*, Oshawa, ON, 57-63.
- [3] S. Satsangi and G. B. Kumbhar, 2016, "Review on Volt/Var Optimization and Control in Electric Distribution System," *Proceedings IEEE 1st International Conference on Power Electronics, Intelligent Control and Energy Systems (ICPEICES)*, Delhi, 2016, 1-6.
- [4] European Commission, "Sundom Smart Grid",

- EU Project Description*, Available: <https://ses.jrc.ec.europa.eu/sundom-smart-grid-ssg> [Accessed: 24-Oct-2017].
- [5] Fingrid, 2017, "Supply of Reactive Power and Maintenance of Reactive Power Reserves", *Application Instruction*, Available at: http://www.fingrid.fi/en/customers/Customer%20attachments/Grid%20service/Supply%20of%20Reactive%20Power%20and%20Maintenance%20of%20Reactive%20Power%20Reserves_2017.pdf [Accessed: 24-Oct-2017].
- [6] H. Laaksonen and P. Hovila, 2017, "Future-proof Islanding Detection Schemes in Sundom Smart Grid," *CIRED Conference on Electricity Distribution*, Glasgow.
- [7] H. Laaksonen and P. Hovila, 2016, "Flexzone concept to enable resilient distribution grids — Possibilities in Sundom Smart Grid," *Proceedings CIRED Workshop*, Helsinki, 2016, 1-4.
- [8] S. Uebermasser, C. Groiss, A. Einfalt, N. Thie, M. Vasconcelos, J. Helguero, H. Laaksonen and P. Hovila, 2017, "Requirements for Coordinated Ancillary Services Covering Different Voltage Levels," *Proceedings CIRED Conference on Electricity Distribution*, Glasgow.
- [9] Commission Regulation (EU) 2016/1388, Network Code on Demand Connection. Available: <https://publications.europa.eu/en/publication-detail/-/publication/514fd1e3-650b-11e6-9b08-01aa75ed71a1/language-en/format-PDF/source-44168342> [Accessed: 24-Oct-2017].
- [10] H. Laaksonen, P. Hovila and K. Kauhaniemi, 2018 "Combined Islanding Detection Scheme Utilizing Active Network Management for Future Resilient Distribution Networks," *Proceedings The 14th International Conference on Developments in Power System Protection*, unpublished, Belfast, UK.
- [11] P. Giroux, G. Sybille, J. Brochu, and P. Brunelle, "One-Year Simulation in One Minute", Simulation Model of an Energy Storage System Used on a Power Grid, Available: <https://se.mathworks.com/matlabcentral/fileexchange/51137-one-year-simulation-in-one-minute> [Accessed: 24-Oct-2017].
- [12] Council of State Finland, 2009, "2009/66 Valtioneuvoston asetus sähkötoimitusten selvityksestä ja mittauksesta", Available: <http://www.finlex.fi/fi/laki/ajantasa/2009/20090066#L5P2> [Accessed: 24-Oct-2017].
- [13] Mervento, 2012, Mervento 3.6-118, Datasheet. Available: <https://en.wind-turbine-models.com/turbines/296-mervento-3.6-118> [Accessed: 24-Oct-2017].
- [14] Ilmatieteen laitos, Observation stations, Available: <http://en.ilmatieteenlaitos.fi/observation-stations> [Accessed: 30-Oct-2017].
- [15] Ilmatieteen laitos, Suomen Tuuliatlas, Available: <http://www.tuuliatlas.fi> [Accessed: 30-Oct-2017].
- [16] JRC Renewable Energies Unit (EU Science Hub), *Photovoltaic Geographical Information System - Interactive Maps, Geographical Assessment of Solar Resource and Performance of Photovoltaic Technology*, Available: <http://re.jrc.ec.europa.eu/pvgis/apps4/pvest.php> [Accessed: 24-Oct-2017].