

**UNIVERSITY OF VAASA**

**FACULTY OF TECHNOLOGY**

**TELECOMMUNICATIONS TECHNOLOGY**

Ali Imran

**ADMISSION CONTROL FOR MULTIUSER COMMUNICATION SYSTEMS**

Master's thesis for the degree of Master of Science in Technology submitted for inspection, Vaasa, 24<sup>th</sup> of June 2010.

Supervisor

D.Sc. (Tech.) Mohammad Salem Elmusrati

Instructor

M.Sc. (Tech.) Reino Virrankoski

## ACKNOWLEDGMENTS

I would like to thank ALLAH for his grace and love. I would like to express my sincere appreciation and gratitude to my supervisor, Mohammad Elmusrati for his guidance throughout my study career at Vaasa.

I am grateful to my Instructor, Reino Virrankoski for his help and continuous guidance to fulfill my thesis and course work. I would like to take the opportunity to thank my colleagues and friends for their constant motivation and useful discussions during my stay in Finland.

Finally, I would like to give my appreciations to my parents for their continuous encouragement and giving me their unconditional care and love.

Ali Imran  
Vaasa, 24<sup>th</sup> of June 2010

## TABLE OF CONTENTS

ACKNOWLEDGMENTS	1
SYMBOLS AND ABBREVIATIONS	4
ABSTRACT	12
1. INTRODUCTION	13
1.1. Study Objectives and Aim	13
1.2. Study Contribution	13
1.3. Focus areas defined Model	14
1.4. Outline of the thesis	15
2. ADMISSION CONTROL	16
2.1. Admission Control Mechanism	17
2.2. Random Processes	18
2.2.1. A Memory less process (Markov process)	18
2.2.2. The Birth-Death Process	18
2.2.3. Steady-State Probabilities and Erlang's loss formula	19
2.3. Modeling of Wireless Networks	21
2.4. Discussion	22
3. CHANNEL ALLOCATION AND ADMISSION CONTROL	23
3.1. Channel Allocation	23
3.2. Non-Borrowing Fix Channel Assignment	25
3.2.1. No Priority Scheme (NPS)	25
3.2.2. Reserved Channel Scheme (RCS)	26
3.2.3. Queuing Priority Scheme (QPS)	27
3.2.4. The Genetic Algorithms Scheme (GAS)	27
3.2.5. Parameters description	28
3.2.6. No priority scheme (NPS) Analysis	28
3.2.7. Reserved Channel Scheme (RCS) Analysis	31
3.3. Call admission control Algorithm flow chart (Guerrero 1999)	35

3.4. Call admission control Algorithm (Guerrero 1999)	36
4. CELL BASED CALL ADMISSION CONTROL WITH QoS	37
4.1 Background	37
4.2. System model	38
4.2.1. Bandwidth Reservation Scheme	40
4.2.2. Call Admission Control (CAC) Algorithm	41
4.2.3. Cell bases call admission control Algorithm Flow chart	42
4.2.4. Assumptions	43
4.2.5. Analysis and Derivations	43
4.2.6. Performance measurements Parameters	45
4.3. Discussion	46
5. POWER BASED ADMISSION CONTROL	47
5.1. Radio Link Performance Indicators	47
5.1.1. The Propagation Problem	48
5.2 System Model	49
5.2.1. Propagation Models	49
5.2.2. Free space path loss (FSL)	50
5.2.3. Okumura Model	50
5.2.4. SUI Model	51
5.3 Load Factors in uplink and downlink Radio Link Budgets	52
5.3.1. Uplink Radio Link Budget	53
5.3.2. Downlink Radio Link Budget	54
5.3.3. Pilot Power Adjustment	54
5.4 Measurement of Air Interface Load and CAC Schemes	56
5.4.1. Wide Band Power Based (WPB) Admission Control	56
5.4.2. Throughput Based (TB) Admission Control	59
5.4.3. Adaptive Call Admission Control	60
5.5 ACAC in Multi-Class through fuzzy logic for congestion control	63
5.5.1. Mathematical model of system services	64

5.5.2.	Service differentiation	65
5.5.3.	Membership Functions	67
5.5.4.	Adaptive Admission and Congestion Control logic	70
6.	ALGORITHMS ANALYSIS AND SIMULATION	72
6.1.	Probabilities Comparison Steps	73
6.1.1.	Comparison of call Blocking Probability	73
6.1.2.	Comparison of Handoff dropping Probability	75
6.1.3.	Comparison of call Forced Termination Probability	76
6.1.4.	Comparison of call Not Completed Probability	78
6.1.5.	Recommendations	80
6.2.	Cell based call admission control Algorithm simulation	80
6.3.	Simulation for multi-class resource reservation	81
6.4.	Call blocking probability on channel sharing	81
6.4.1.	Handoff failure probability on channel sharing	83
6.4.2.	Call blocking probability and handoff failure probability in unfair resource allocation	84
6.5.	Power received graph, Propagation model GoS simulation	86
6.5.1.	Capacity of system and grade of service (GoS)	90
6.5.2.	Results and Conclusion	92
7.	CONCLUSIONS AND FUTURE WORK	94
	REFERENCES	96

## SYMBOLS AND ABBREVIATIONS

### ABBREVIATIONS

3GPP	3 <sup>rd</sup> Generation Partnership Project
AC	Admission control
ACAC	Adaptive call admission control
ACACS	Adaptive call admission control scheme
BR	Bandwidth Reservation
BU	Bandwidth unit
BW	Bandwidth
CAC	Call Admission Control
CAC	Connection Admission Control
CB	Call blocking
CBP	Call blocking probability
CCI	Co-Channel Interference
CD	Call dropping
CDP	Call dropping probability
CS	Complete Sharing
DCAS	Dynamic Channel Allocation scheme
FCAS	Fixed Channel Allocation scheme
FCFS	First Come First Served
FSDCM	Adaptive fuzzy service degradation control model
FSL	Free space path loss

GAS	Genetic Algorithms Scheme
GC	Guard channel
GoS	Grade of service
HCA	Hybrid Channel Allocation
HSDPA	High Speed Downlink Packet Access
ITU-T	The International Telecommunications Union
MGC	Multimedia Guard Channel
MS	Mobile station
NPS	No Priority Scheme
OLPC	Open loop power control
Pb	Blocking rate of new calls
PCS	Personal communication system
Pft	Forced termination
Ph	Handoff failure rate
Pnc	Not completed calls
PQM	Priority-based Queuing Model
PRCS	Prioritized reserved Channel Scheme
QoS	Quality of service
QPS	Queuing Priority Scheme
RCS	Reserved Channel Scheme
RRM	Radio resource management
SUI	Stanford University Interim model
TB	Throughput Based
TBCAC	Throughput Based Admission Control

UMTS	Universal Mobile Telecommunication System
UOLPC	Uplink open-loop power control
WCDMA	Wideband CDMA
WPB	Wide Band Power Based
WPBCAC	Wide Band Power Based Admission Control



## SYMBOLS

$\lambda$	Call arrivals rate
$\mu$	Call service rate
$p_0$	Initial probability
$P_j$	Steady state probability of state 'j'
$P_b$	New call blocking Probability
$P_h$	Handoff call dropping Probability
$P_{ft}$	Call forced termination Probability
$P_{nc}$	Not completed calls Probability
$A, \rho$	Offered traffic
$n$	Remaining number of channels in system
$P_n$	Blocking probability of 'n' calls
$\mu_T$	Total call service rate
$\lambda_{hi}$	Handoff call arrival
$\lambda_T$	Total incoming call in system
$\lambda_0$	New call arrival
$s$	Total number of channels
$P_s$	Probability of 's' type traffic
$C_h$	Reserved channels
$\lambda_{ho\_new}$	Current handoff calls in system
$class-i$	<i>Class 'i' traffic</i>
$C$	<i>Capacity</i>
$C_i$	<i>Capacity of 'i' class</i>

$t_1, t_2, t_3, \text{ and } t_4$	Threshold level of class 1,2,3,4 respectively
$r_1, r_2, r_3, \text{ and } r_4$	Reserve channels for class 1,2,3,4 respectively
$'i'$ class	$i=2$ ,means new and hand over
$C_{nc_i}$	Total bandwidth occupied by class- $i$ new calls
$C_{h_i}$	Total bandwidth occupied by class- $i$ handoff calls
$C_{OB}$	Total bandwidth occupied in a cell
$\lambda_{nc_i}$	New call arrivals of class $i$
$\lambda_{h_i}$	Handoff call arrivals of class $i$
“ $h_m$ ”	Height of mobile
“ $h_b$ ”	Height of base station
$f_c$	Carrier frequency
$\alpha(h_m)$	Correction factor for mobile antenna height
$L_p$	Path loss
D	Distance between MS and BS
$X_f$	Frequency Correction factor
$X_h$	BS height Correction factor
S	Shadowing
$\gamma$	Path loss factor
a, b and c	Terrain A parameters
PG	Processing gain
$\frac{E_b}{N_o}$	Signal to noise ratio
$v_j$	Voice activity factor
W	Chip rate

$R_j$	Bit rate
$L_j$	Load factor of connection(s)
$\eta_{j,ul}$	Uplink load factor
$i$	Interference ratio
$\eta_{j,dl}$	Downlink load factor
$\alpha_j$	Orthogonality factor
$P_{rx\ Total}$	Total received power
$NR_j$	Noise rise of 'j' user(s)
$I_{own}$	Received power from users in the own cell
$I_{other}$	Interference from users in the surrounding cells
$N_j$	Total noise power
$\eta_{j,ul,new}$	New uplink load factor
$\eta$	Load before admitting new user
$\Delta L$	Load change
$\alpha$	Predict number of call in coming period
$\beta$	Count of total number of calls initiate in the system from start
$\hat{V}_{n+1}$	Number of voice calls in the coming period
$\hat{D}_{n+1}$	Number of data calls in the coming period
$\lambda(k)_{new}$	New call in $k$ service type
$\lambda(k)_h$	Handoff call in $k$ service type
$\mu(k)$	service rate in $k$ service type
$\lambda^T$	Total arrival rate
$\mu^T$	Total service rate

$BW(k)$	Bandwidth of $k$ service Type
$\alpha(k)$	Priority coefficient
$\beta(k)$	Resource demand coefficient
$N(k)(t)$	Class $k$ service at time $t$
$S$	State space
$Q$ (BU)	Waiting queue bandwidth units
$C$ (BU)	Total system BWU
$P_{drop}(k)$	Handoff call dropping of $k$ service
$P_{block}(k)$	New call block of $k$ service
$\Delta(k)$ drop	Change in $k$ service
$P(k)$ drop ,tolerance	Worst-case handoff call dropping probability
$\gamma D$	Degradation degree
$\gamma D_{max}$	Maximum degradation degree
$\gamma D C$	Incoming handoff calls after no resources left
$(1 - \gamma D)C$	Squeezed existing services to accommodate $\gamma D C$
$\gamma D_{in}$ , $\gamma D_{out}$	Variable of degradation decision

---

**UNIVERSITY OF VAASA****Faculty of Technology****Author:**

Ali Imran

**Topic of the Thesis:**

Admission Control for Multiuser Communication Systems

**Supervisor:**

Mohammad Salem Elmusrati

**Instructor:**

Reino Virrankoski

**Degree:**

Master of Science in Technology

**Department:**

Department of Computer Science

**Degree Programme:**

Degree Programme in Information Technology

**Major of Subject:**

Telecommunication Engineering

**Year of Entering the University:** 2007**Year of Completing the Thesis:** 2010**Pages: 100**

---

**ABSTRACT**

During the last few years, broadband wireless communication has experienced very rapid growth in telecommunications industry. Hence, the performance analysis of such systems is one of the most important topics. However, accurate systems' analysis requires first good modeling of the network traffic. Moreover, broadband wireless communication should achieve certain performance in order to satisfy the customers as well as the operators. Therefore, some call admission control techniques should be integrated with wireless networks in order to deny new users/services if accepting them will lead to degrade the network performance to less than the allowed threshold. This thesis mainly discusses the above two issues which can be summarized as follows. First issue is the traffic modeling of wireless communication. The performance analysis is discussed in terms of the quality of services (QoS) and also the grade of services (GoS). Different scenarios have been studied such as enhancing the GoS of handover users. The second issue is the admission control algorithms. Admission Control is part of radio resource management. The performance of admission control is affected by channel characteristics such as fading and interference. Hence, some wireless channel characteristics are introduced briefly. Seven different channel allocation schemes have been discussed and analyzed. Moreover, different admission control algorithms are analyzed such as power-based and multi-classes fuzzy-logic based. Some simulation analyses are given as well to show the system performance of different algorithms and scenarios.

---

**KEYWORDS:** Admission control, Markov Models, Channel Allocation, Call blocking, Power Control, Propagation Models, Uplink and Downlink Radio Links, Fuzzy logic.

## 1. INTRODUCTION

The demand of higher bandwidth increases rapidly due to introduction of data calls in cellular network. The researcher has divided bandwidth resources among multiple classes of user to fulfill new demands of quality of service (QoS). In cellular systems, admission control ensures the system to meet its quality of service. There are tradeoffs between QoS and traffic load in a network. For network to work smoothly, we need to limit incoming rate of calls or to utilize the available resources in a maximum level to avoid network congestion. In addition, researchers are interested in limiting call blocking and dropping probabilities either by distributing number of channels amongst new calls and handoffs.

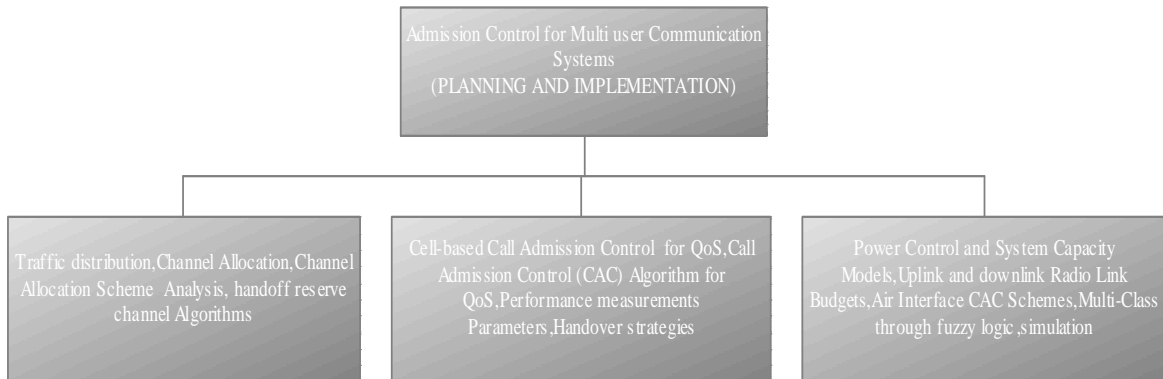
### 1.1. Study Objectives and Aim

As the bandwidth is limited and not to be wasted, network engineers perform traffic analysis and optimization to maintain QoS. Traffic distribution based on channel allocation depends on user registry. The aim of this thesis is to study different schemes to maximize system capacity and make decisions on admission control. This minimizes extra handoff by adopting reserved channel scheme (RCS) for handoff calls. In addition, the effective mobility management for slow, medium and fast traffic also reduces system burden.

### 1.2. Study Contribution

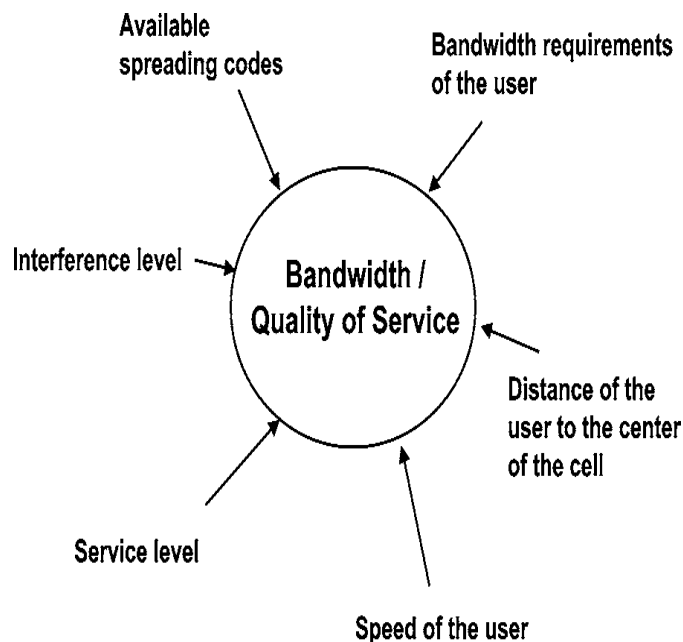
This thesis gives research problem area in admission control on theoretical and simulation platform by providing concepts and results. This thesis also gives an idea of how important is to identify the problem of multi-class resource assignment in future networks.

### 1.3. Focus areas defined Model



**Figure 1.** Defined Model.

The core of admission control include shaping bandwidth requirements ensuring QoS by determining interface level, speed of users, and distance from base station and the factors involved in it.



**Figure 2.** Factors influencing the quality of service and the maximum bandwidth of a connection (Sauter 2006:164).

#### 1.4. Outline of the thesis

In this chapter, the importance of the topic is defined. Second chapter is based on packet data networks in wireless communications, random processes, steady-state Probabilities and capacity equations. Third chapter based on introduction of channel assignment schemes, handoff reservation channel scheme, algorithms for blocking and dropping probabilities by reserving handoff channels to maximize QoS. In chapter four, we have discussed the ability of cellular network to provide different types of services for different classes of traffic. The basic function of admission control algorithms is to decide on admitting new user into system only when QoS parameters are satisfied. Admission control whole mechanism based on multi cellular environment with power and throughput control algorithms.

Chapter 5 includes radio link performances measurements and significant factors involved in determining the power from each base station (BS). The selection of connection admission based on the BS receive power graph. Pathloss problem can be reduced by selecting suitable pathloss model to minimize handoffs and maximize QoS. In addition, we discussed load calculation for call admission control (CAC) Schemes on power and throughput based admission control. Finally, Adaptive CAC techniques through fuzzy logic for multi-class CAC scheme for congestion control have been discussed. Last chapter contain simulation results related to call admission control algorithms and handoff minimization based on received signal strength.



## 2. ADMISSION CONTROL

A radio resource management (RRM) technique has been used for the efficient use of resources in wireless communication. To achieve the minimum required quality of service (QoS), the available resources have to be used effectively. Call admission control (CAC) takes decisions on call acceptance based on prediction of impact on network resources. The quality of service according to The International Telecommunications Union (ITU-T) ensures QoS requirements of customer, QoS planned by provider, QoS delivered by provider, QoS perceived by customer (Laiho et al. 2006:457). The *radio resource control (RRC)* layer broadcasts system information, handles radio resources (i.e., code allocation, handoff, admission control, and measurement/control report), and controls the requested QoS (Garg 2007:498,661).

The focus in this thesis is to achieve the Target QoS. Different factors should be considered such as: Blocking probability, dropping probability, blocking and dropping in different types of traffic, force termination probability, required grade of service (GoS), uplink and Downlink load factors, effective bandwidth (BW) allocation among users, load control, active connection and others. Effective link layer capacity optimization includes efficiency in admission control and resource reservation that guarantee target QoS (Glisic 2006:244).

According to (Lee 2006:335), these factors increase service quality and come under admission control (AC) based on network planning and power control. A problem in wireless communication is limitedly available radio-frequency spectrum. The intelligent base station assigns resources to mobile stations intelligently for power control and power adjustment to tackle the near far problem. In addition, it makes smart handoffs between base stations. (Lee 2006:20) Traffic distribution parameter includes user mobility, cell size of the wireless link, cell capacity, network load, scheduling at the base stations, handoff, and location management. To maintain quality of service (QoS) the traditional approach based on the Erlang-B formula given by Erlang, a Danish pioneer of teletraffic theory in telecommunication networks.

QoS also include large coverage area because mobile users are unevenly scattered within the wireless coverage area. It is not possible to have 100% coverage due to the fact that we have to increase transmitting power to cover weak spots. Secondly, it is even harder to control interference in high transmitting power. Required *grade of service* (GoS) is specified by blocking probability of users. In general, blocking probability in a cell sites should be less than two percent. It also needs a good system planning and a sufficient number of radio channels availability. Thirdly, the total *number of dropped calls* must be kept low. Call dropping causes coverage problems and handoff problems directly related to channel availability or weak reception. (Lee 2006:28) the cellular systems is defined by two main user states. First busy users, which have an ongoing connection (e.g., allocated time slot) secondly, Idle users, which are attached to the network (i.e., mobile terminal is turned “on”) but are not active at a particular time (Janevski 2003:84).

## 2.1. Admission Control Mechanism

Admission control mechanism in wireless system helps in decision making for granting the available resources for incoming requests. The number of connections in a cell is based on capacity of the specific wireless network. In GSM, it is the part of base station controller (BSC) but in present communication, intelligent base station (BS) itself has authority to reject or accept calls. (Lee 2006:20; Janevski 2003:83) We have two models to calculate the blocking probabilities of wireless communication systems. The first model is *pure loss or blocking system model*, where blocked calls cleared with zero holding time (no buffering). This model is based on Erlang’s-B distribution. The second model is *queuing system model* based on Erlang’s-C distribution that is mostly use in data calls. (Hammuda 1997:134)

## 2.2. Random Processes

Random events are hardly predictable. One simple example of random event is throwing a coin. In coin, we have two possible events, a head or a tail. In this thesis,  $\lambda$  is symbolized as call generation and  $\mu$  is call serviced either, completed or handoff to another cell. There are two groups of Random variables.

- Discrete random variables are limited and bounded, if we observe a number of busy channels or number of events in given time interval (e.g., call arrivals  $\lambda$ , call servicing  $\mu$ ).
- Continuous random variables (we take time as a continuous random event such as waiting time, busy time, and inter arrival time).

### 2.2.1. A Memory less process (Markov process)

The future state at any given time depends only on its present state current value  $x_n$ , but not on past value, where the probability of the next value  $x_{n+1}$  can be expressed as,

$$\Pr \{ X_{n+1} = x_{n+1} \mid X_n = x_n \} \quad (2.1)$$

The equation (2.1) is used only for memory less process (Janevski 2003:91-99).

### 2.2.2. The Birth-Death Process

As we are interested in continuous-time processes, the birth-death process is a continuous time Markov process. Here, the transitions occur between adjacent states only or leave the state unchanged. When a birth occurs, the process goes from state  $k$  to  $k+1$ . When a death occurs, the process goes from state  $k$  to state  $k-1$ . The maximum chance to occur a state is one. (Janevski 2003:100-103)

$$\sum_{j=0}^s P_j = 1 \quad (2.2)$$

### 2.2.3. Steady-State Probabilities and Erlang's loss formula

The steady state probability that the system is in state 'j' ( $j \in N$ ) can be written as ' $P_j$ ',

$$P_j = \lim_{t \rightarrow \infty} P_j(t) \quad (2.3)$$

Whereas,  $P_j(t)$  denotes the probability of 'j' calls in the system at time 't'. (Willig 1999:11).As,

$$\lambda_0 P_0 = \mu_1 P_1 \text{ similarly, } \lambda_{j-1} P_{j-1} = \mu_j P_j \quad (2.4)$$

And, the steady state probability that the system is in state 'j' can also be written as,

$$P_j = \frac{(A)^j}{j!} P_0 \quad (2.5)$$

Where  $A = \lambda/\mu$ , offered traffic per cell and clearly assuming that,  $A < 1$ . The *carried* traffic is the volume of traffic actually carried by a cell, and *offered* traffic is the volume of traffic offered to a cell. (Garg 2007:24) then ' $P_j$ ' is as follows,

$$P_j = \frac{\left(\frac{\lambda}{\mu}\right)^j}{j!} P_0 \quad (2.6)$$

Putting equation (2.6) in equation (2.2) we get,

$$P_o = \frac{1}{\sum_{k=0}^n \frac{\left(\frac{\lambda}{\mu}\right)^k}{k!}} \quad (2.7)$$

Putting the value of  $P_o$  from equation (2.7) in (2.6), we get the Erlang's formula and can be expressed as, (Stüber 2002:33; Janevski 2003:127)

$$P_j = \frac{\frac{\left(\frac{\lambda}{\mu}\right)^j}{j!}}{\sum_{k=0}^n \frac{\left(\frac{\lambda}{\mu}\right)^k}{k!}} \quad (2.8)$$

Whereas “ $j$ ” is the total number of communication channels and  $A = \lambda/\mu$  is offered traffic. In a condition when all the available number of channels in system are busy then from equation (2.8) for  $j = n$  can be written as *Blocking probability of Erlang's distribution*. Where  $n$  are number of busy channels in system. (Garg 2007:40)

$$P_b = P_j = \frac{\frac{\left(\frac{\lambda}{\mu}\right)^j}{j!}}{\sum_{k=0}^n \frac{\left(\frac{\lambda}{\mu}\right)^k}{k!}} = \frac{\frac{(A)^j}{j!}}{\sum_{k=0}^n \frac{(A)^k}{k!}} = P_n = \frac{\frac{(A)^n}{n!}}{\sum_{k=0}^n \frac{(A)^k}{k!}} \quad (2.9)$$

If we increase the number of traffic types then multidimensional Erlang's loss formula we obtain can be written as, (Janevski 2003:119)

$$P_b = P_j = \frac{\frac{\left(\sum_{i=0}^n \frac{\lambda}{\mu}\right)^j}{j!}}{\sum_{k=0}^n \frac{\left(\sum_{i=0}^n \frac{\lambda}{\mu}\right)^k}{k!}} = \frac{\frac{(\sum_{i=0}^n A)^j}{j!}}{\sum_{k=0}^n \frac{(\sum_{i=0}^n A)^k}{k!}} \quad (2.10)$$

### 2.3. Modeling of Wireless Networks

For the modeling of wireless systems, we need to consider following parameters such as new call arrival rate, handoff call arrival rate, average call holding time, new call blocking probability and handoff call blocking probability. Consider a user that initiate a fresh call as a Poisson process at rate  $\lambda_1 = \lambda_n$  and receives no handoffs. The Mean value that the call complete without handoff is equal to  $\frac{1}{\mu}$  and mean value that the call complete with handoff is  $\frac{1}{\eta}$ . Whereas, service rate for new call complete is  $\mu$ , and service rare of handoff calls is  $\eta$ . The total call service rate =  $\mu_T = \mu + \eta$ . (Janevski 2003:127) According to (Janevski 2003) using Little's result traffic intensity "A" can be expressed as,

$$A_1 = \frac{\lambda_1}{\mu_T} \quad (2.11)$$

We have calculated blocking probability for new calls by using the Erlang's-B formula.

$$Pb_n = \frac{\frac{\left(\frac{\lambda_1}{\mu_T}\right)^n}{n!}}{\sum_{i=0}^n \frac{\left(\frac{\lambda_1}{\mu_T}\right)^i}{i!}} = \frac{\frac{(A_1)^n}{n!}}{\sum_{i=0}^n \frac{(A_1)^i}{i!}} \quad (2.12)$$

As, the total incoming call in system is the sum of new and handoff calls.

$$\lambda_T = \lambda_o + \lambda_{hi} \quad (2.13)$$

Then effective offered traffic as follows, (Janevski 2003:128)

$$A_e = \frac{\lambda_T}{\mu_T} = \frac{\lambda_o + \lambda_{hi}}{\mu + \eta} \quad (2.14)$$

The handoffs are not self-determining processes and depends on the new call arrivals in the cells. If there is no new call, there is no handoff. If there is no reserve channels for handoffs call then, new call blocking probability  $P_B$  equal to handoff call blocking probability by using Erlang's-B formula with effective offered traffic. (Janevski 2003:128)

$$P_b = P_h = Pb_n = \frac{\left(\frac{\lambda_n}{\mu}\right)^n}{n!} = \frac{(A_e)^n}{n!} \quad (2.15)$$

$$\frac{\left(\frac{\lambda_1}{\mu}\right)^i}{\sum_{i=0}^n \frac{(\lambda_1/\mu)^i}{i!}} \quad \frac{\sum_{i=0}^n \frac{(A_e)^i}{i!}}$$

$P_b = P_h$  Only when there is no reserve channel left for handoffs then probability of blocking is equal to probability of handoff blocking. Where “ $n$ ” is the total number of channels in cell. From equation (2.15) we have shown that probability of blocking handoff call and new call in a cell is same if and only if reserved channels are zero or currently in use.

#### 2.4. Discussion

Cellular wireless networks based on assumption of Poisson arrival processes and exponential distribution of service time. On the bases of traditional Erlang's-B formula, we extend the scenario of one traffic type to multiple traffic type shown in equation (2.10), that result in multidimensional Erlang's loss formula. Some changes are required in process of flat traffic control and handoff overcomes. In next chapter, we plan to reserve the channels for handoff from total available channels in cell. This guarantees the completion of handoff call and thus reduces call-dropping probabilities.

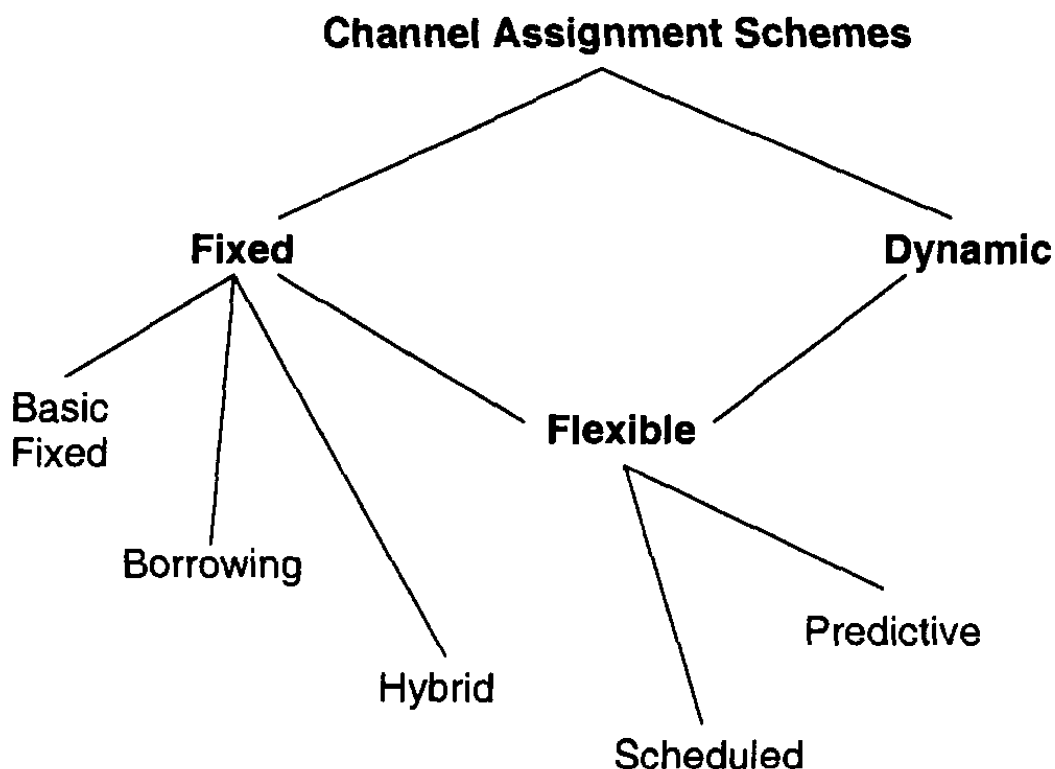
### 3. CHANNEL ALLOCATION AND ADMISSION CONTROL

According to (Hammuda 1997) we consider spread spectrum multiple access and hexagons shape cells are assumed to avoid large interference between users of different cells. Base station in each cell provides air interference. The “Cell sizes depending on type of subscriber station, antenna, site conditions and transmit Power” (Sauter 2006:259). To measure the performance of wireless network we calculate channels/MHz/ square Km, Erlang blocking probability/MHz/square KM, and users/MHz/ square Km (Hammuda 1997:13-17). To overcome co-channel interference (CCI) all the Channels allocated in a way that they try to cancel the interference of adjacent cell in the networks. Then the concept of frequency reuse comes into account. (Lee 2006:45)

#### 3.1. Channel Allocation

According to (Siddiqui 2004), the current growth in wireless communications made necessary to use efficient radio spectrum schemes. In current channel allocation schemes, we have new calls and handoff calls in system. The simultaneous use of available channel comes under optimal channel allocation scheme. (Siddiqui 2004) To minimize the rate of call drops, researchers have proposed different channel allocation schemes granting reserved channel for handoffs calls. In this chapter, non-prioritized scheme and reserved channel allocation schemes for handoff calls is discussed in detail. The two previous mention schemes are non-borrowing fixed channel allocation schemes.

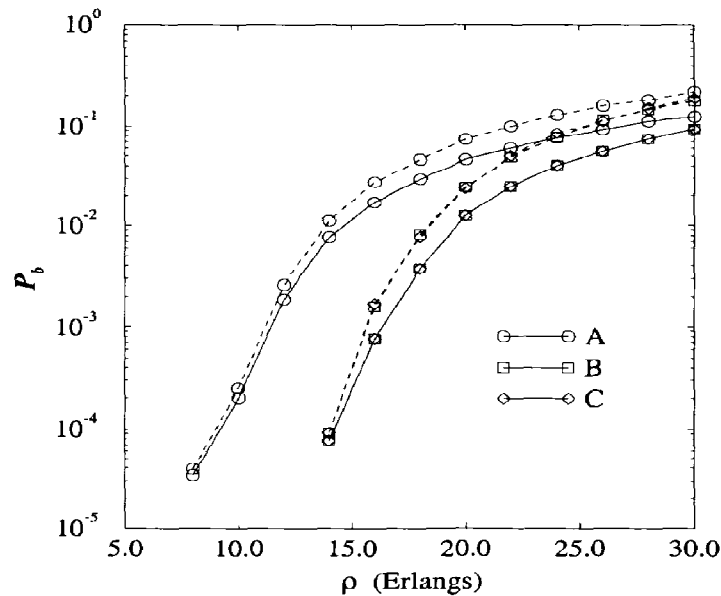




**Figure 3.** Channel assignment schemes (Stüber 2002:646).

To avoid blocking of new and handoff calls in those cells where traffic is high, the combined scheme for fix, dynamic and hybrid channel allocation is used. (Guerrero 1999) In personal communication system (PCS) the mobile station (MS) use a common signaling channel to get communication channel but in other systems MS request traffic channel directly. In either case, if channel is not available the call is blocked. (Siddiqui 2004) Fix channel allocation strategies widely used in 2.5G and 3G systems such as HSCSD, GPRS, cdma2000 (F.A Cruz-Perez and Guerrero 2003). In this thesis, we are also interested to minimize the new call blocking rate, handoff dropping rate, call forced termination rate and call not completed rates for both no priority and reserve channel scheme. This analytical method is valid for uniform traffic distribution. “Forced terminations of calls in progress are worse than blocking of new calls. Forced terminations or handoff blocking occurs when an active call crosses a cell boundary, and the target cell cannot accommodate the additional call” (Stüber 2002:670). The availability of channel in a system occurs when a call is terminated due to handoff, or

on completion of request. Each cell has a set of carrier in use. The cell tends to use their own carriers before borrowing carriers from other cell called borrowing channel assignment (BCA). (Stüber 2002)



**Figure 4.** Probability of new call blocking verses offered traffic without queuing, A=FCA, B=DCA, C= Aggressive DCA (Stüber 2002:680).

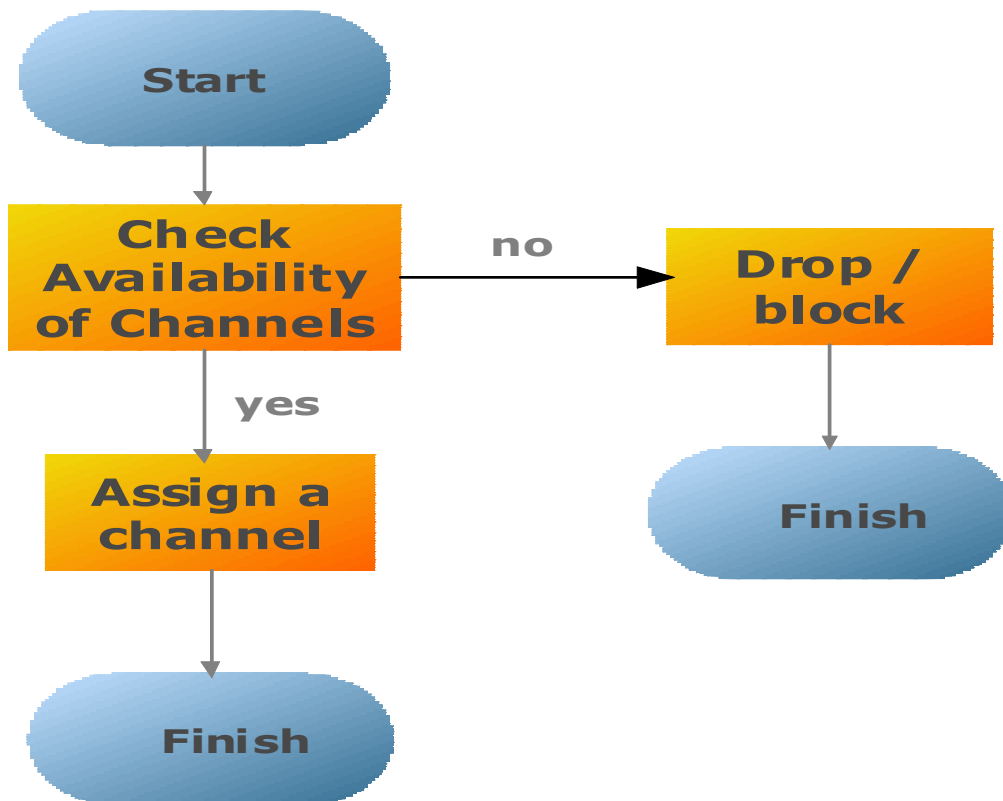
### 3.2. Non-Borrowing Fix Channel Assignment

The non-borrowing fix channel allocation can be divided into following categories in channel allocation schemas.

#### 3.2.1. No Priority Scheme (NPS)

No priority scheme (NPS) follows First in first out (FIFO) method a approach for call handling, but this scheme does not offer QoS support. (Janevski 2003:6) In NPS, each cell has same priority, it means non-prioritized scheme either for new call and handoffs. In NPS only one channel is assign to each request. The blocking probability and handoff failure have partially control by DCA of channels. The NPS scheme is better for those

cells with low traffic intensity. The DCA scheme used as last resort when we have high traffic in NPS cells. (Siddiqui 2004; Janevski 2003; Guerrero 1999)

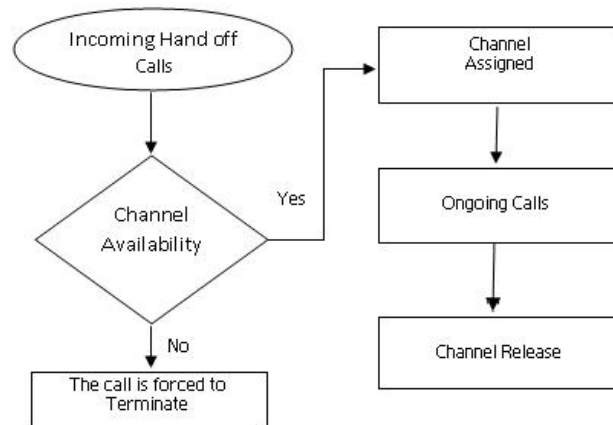


**Figure 5.** No Priority Scheme (NPS).

### 3.2.2. Reserved Channel Scheme (RCS)

RCS is dynamically gives priority to every function. Functions like new call attempts and handoffs channel allocations. In normal condition, highest priority is given for handoffs calls and then for new call attempts, however it is possible to set your own priority as system requirements. Handoffs reserved channels uses FCA scheme and remaining channels using DCA scheme, help the network to reduce probabilities of new call blocking probability, handoff-dropping probability, call forced termination probability and, call not completed probability. An increase in system performance has

been observed by varying threshold value to optimize the parameters in different traffic conditions. (Siddiqui 2004; Guerrero 1999)



**Figure 6.** Flow chart of prioritized reserved Channel Scheme (PRCS).

### 3.2.3. Queuing Priority Scheme (QPS)

The handoff call is queued if there is no available channel in destination cell when MS send its request to BS. If a channel in destination cell is unavailable before crossing handoff area then call termination occur. If there is number of calls in queue then system fallow First in First out (FIFO). (Siddiqui 2004)

### 3.2.4. The Genetic Algorithms Scheme (GAS)

The channel assignment based on local state-based policies of call admission control is known as Genetic Algorithms Scheme (GAS). All other schemes have priority of handoff calls either by queuing or reserving channels for handoff calls. The purpose of these schemes is to reduce Probability of not completed calls. Results in (Siddiqui 2004) shows that the proposed RCS have better results than the NPS in terms of call completion probability.

### 3.2.5. Parameters description

In (Guerrero 1999; Siddiqui 2004) the call Blocking, call handoff failure, call forced termination and not completed calls probabilities have been driven. Then the total probability is given by  $P_j$  as, (Guerrero 1999; Siddiqui 2004; Janevski 2003)

$$P_j = \frac{(\lambda_o + \lambda_{hi})^j}{j! (\mu + \eta)} P_0 \quad (3.1)$$

Here in the cell, call intensities are denoted as call arrival intensity =  $\lambda_o$ , handoff call arrival intensity =  $\lambda_{hi}$ . The total arrival rate and departure rate in NPS is as follows,

$$\lambda_T = \lambda_o + \lambda_{hi} \quad (3.2)$$

$$\mu_T = \mu + \eta \quad (3.3)$$

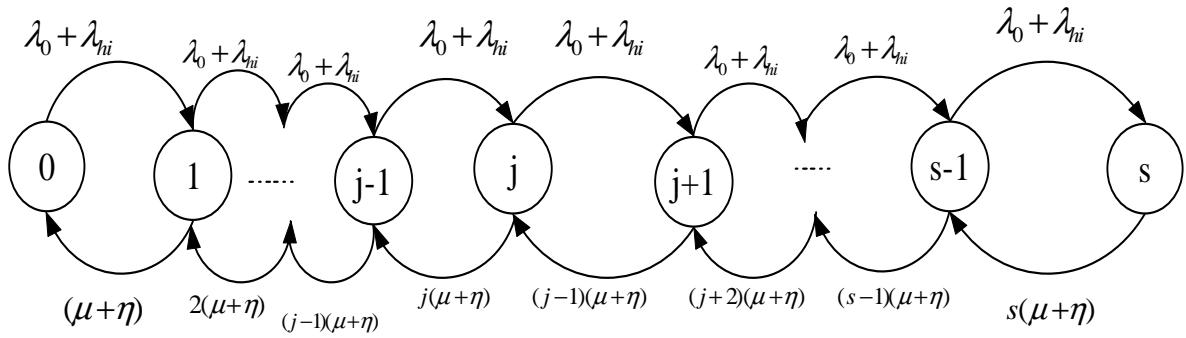
As,  $\mu_T$  is the total service intensity, where service intensity for handoff call is  $\mu$  and for cell with no handoff is  $\eta$ .

### 3.2.6. No priority scheme (NPS) Analysis

In No priority scheme (NPS), all users have same priority on channels availability in the cell. We consider that  $s$  is the total available number of channels. The channel granted, when there is free channel otherwise, call is rejected. In NPS (Siddiqui 2004; Janevski 2003) gives total arrival intensity as,

$$\lambda_T = \lambda_0 + \lambda_{hi} \quad (3.4)$$

The service intensity in a system is  $(\mu + \eta)$ .



**Figure 7.** State Diagram NPS. (Guerrero 1999; Siddiqui 2004).

From Figure (7) probability  $P_j$  for  $0 \leq j < s$  is as follows, (Guerrero 1999)

$$P_j = \frac{\left(\frac{\lambda_0 + \lambda_{hi}}{(\mu + \eta)}\right)^j}{j!} P_0 \quad (3.5)$$

Whereas,  $P_0$  is the probability of zero state.

$$\sum_{j=0}^s P_j = 1 \quad (3.6)$$

Putting equation (3.5) in (3.6), we get  $P_0$  and can be expressed as,

$$P_0 = \frac{1}{\sum_{k=0}^s \frac{\left(\frac{\lambda_0 + \lambda_{hi}}{\mu + \eta}\right)^k}{k!}} \quad (3.7)$$

By substituting equation (3.5) and (3.7) we get, (Guerrero 1999).

$$P_j = \frac{\frac{\left(\frac{\lambda_0 + \lambda_{hi}}{\mu + \eta}\right)^j}{j!}}{\sum_{k=0}^s \frac{\left(\frac{\lambda_0 + \lambda_{hi}}{\mu + \eta}\right)^k}{k!}} \quad (3.8)$$

Suppose the total available channel in cell of traffic type 'j' is 's', then to find  $P_b$  at  $j=s$  the equation (3.8) becomes, (Guerrero 1999; Siddiqui 2004)

$$P_b = P_s = \frac{\left(\frac{\lambda_0 + \lambda_{hi}}{\mu + \eta}\right)^s}{s!} \left[ \sum_{k=0}^s \frac{\left(\frac{\lambda_0 + \lambda_{hi}}{\mu + \eta}\right)^k}{k!} \right]^{-1} \quad (3.9)$$

Reason for keeping  $j=s$  because arrival rate of  $j$  calls and  $s$  calls in the cell for no prioritized scheme is same. The call dropping probability  $P_h$  is as follows, (Guerrero 1999; Siddiqui 2004)

$$P_h = \frac{\left(\frac{\lambda_0 + \lambda_{hi}}{\mu + \eta}\right)^s}{s!} \left[ \sum_{k=0}^s \frac{\left(\frac{\lambda_0 + \lambda_{hi}}{\mu + \eta}\right)^k}{k!} \right]^{-1} \quad (3.10)$$

As, (Guerrero 1999) consider blocking probability of handoff and new call is same in NPS because we have same priorities for both types of calls. (Siddiqui 2004; Guerrero 1999)

$$P_h = P_b \text{ and } P_b = P_s, \text{ only if } j = s \quad (3.11)$$

The priority of handoff call generate in cell is same as new call generation probability in NPS. Equation (3.10) already approved in Chapter two, as equation (2.15) for multidimensional traffic type calls.

### 3.2.7. Reserved Channel Scheme (RCS) Analysis

For reserved channel scheme, consider that the total available channels are 's' channels from which 'Ch' channels are reserved. The number of channels left in system are as follows,

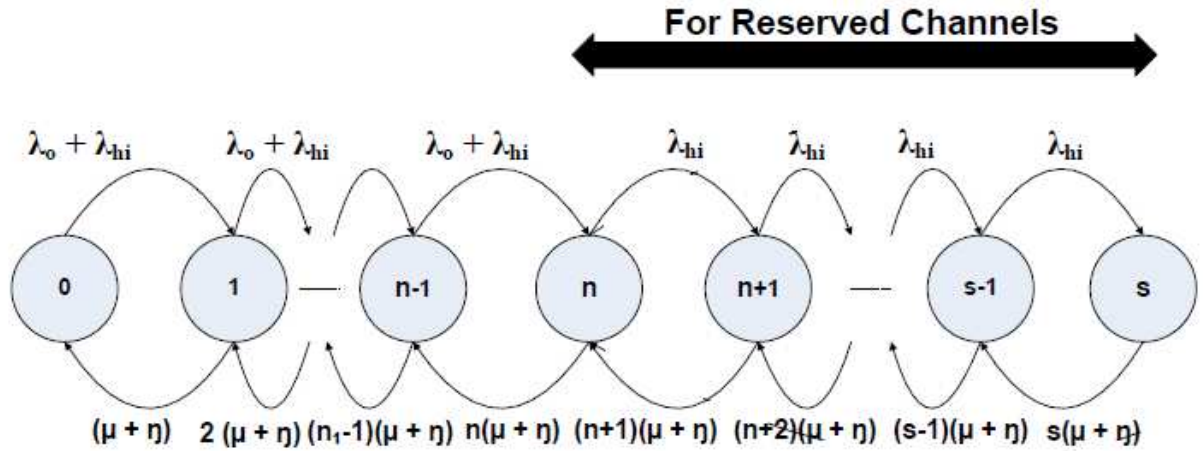
$$n = s - (Ch) \quad (3.12)$$

Arrival intensity  $\lambda$  for  $n$  channels in RCS can be expressed as, (Siddiqui 2004).

$$\lambda_T = \lambda_o + \lambda_{hi} \text{ and } \lambda_T = \lambda_{hi}, \text{ otherwise} \quad (3.13)$$

From Figure (8), the total call arrival rate is  $\lambda_T = \lambda_o + \lambda_{hi}$  from zero to 'n' and from 'n+1' to 's' is  $\lambda_T = \lambda_{hi}$ . In equation (8), arrival intensity for handoff calls is  $\lambda_{hi}$ , and the new call arrival intensity is  $\lambda_o$  where, the total number of states are 's+1' states.





**Figure 8.** State Diagram RCS (Guerrero 1999).

The state diagram of reserve channel scheme is shown in Figure (8). If new call enter in system it will be blocked if and only if 'n' channels are busy but handoff call will be accepted. From Figure (8), the steady state probability is given by  $P_j$  and can be expressed as, (Guerrero 1999).

$$P_j = \frac{(\lambda_0 + \lambda_{hi})^j}{j! (\mu + \eta)^j} P_0 \quad \text{for } 0 \leq j < n \quad (3.14)$$

$$P_j = \frac{(\lambda_{hi})^{j-n} (\lambda_0 + \lambda_{hi})^n}{j! (\mu + \eta)^j} P_0 \quad \text{for } n \leq j < s \quad (3.15)$$

Whereas, according to Figure (8), equation (3.14) and equation (3.15) are independent. The initial probability 'Po' can be expressed as, (Guerrero 1999; Siddiqui 2004).

$$P_0 = \left[ \sum_{j=0}^n \frac{(\lambda_0 + \lambda_{hi})^j}{j! (\mu + \eta)^j} + \sum_{j=n+1}^s \frac{(\lambda_{hi})^{j-n} (\lambda_0 + \lambda_{hi})^n}{j! (\mu + \eta)^j} \right]^{-1} \quad (3.16)$$

In the above equation, the first part is the incoming and outgoing traffic for channel '0' to 'n' and can be expressed as

$$\sum_{j=0}^n \frac{\left(\frac{\lambda_0 + \lambda_{hi}}{\mu + \eta}\right)^j}{j!} \quad (3.17)$$

The second part of equation (3.16) is incoming and outgoing traffic for channel above n, is n + 1 to s for reserved channel scheme and can be expressed as, (Siddiqui 2004).

$$\sum_{j=n+1}^s \frac{(\lambda_{hi})^{j-n} (\lambda_0 + \lambda_{hi})^n}{j! (\mu + \eta)^j} \quad (3.18)$$

The probability that the cell receives a call when the system is in state (n→s) then the new call blocking probability is as follows,

$$P_b = \sum_{j=n}^s P_j \quad (3.19)$$

Whereas, call blocking probability from (n→s) is given as,(Guerrero 1999; Siddiqui 2004).

$$P_b = \frac{(\lambda_{hi})^{j-n} (\lambda_0 + \lambda_{hi})^n}{j! (\mu + \eta)^j} \left[ \sum_{j=0}^n \frac{\left(\frac{\lambda_0 + \lambda_{hi}}{\mu + \eta}\right)^j}{j!} + \sum_{j=n+1}^s \frac{(\lambda_{hi})^{j-n} (\lambda_0 + \lambda_{hi})^n}{j! (\mu + \eta)^j} \right]^{-1} \quad (3.20)$$

The handoff call dropping take place when there is no reserve channel left in system for handoff calls in other terminology, Ch=0 then from equation (3.12), we get n = s. Therefore, Probability of handoff calls drop for reserve channel scheme (RCS) as follows, (Siddiqui 2004; Guerrero 1999).

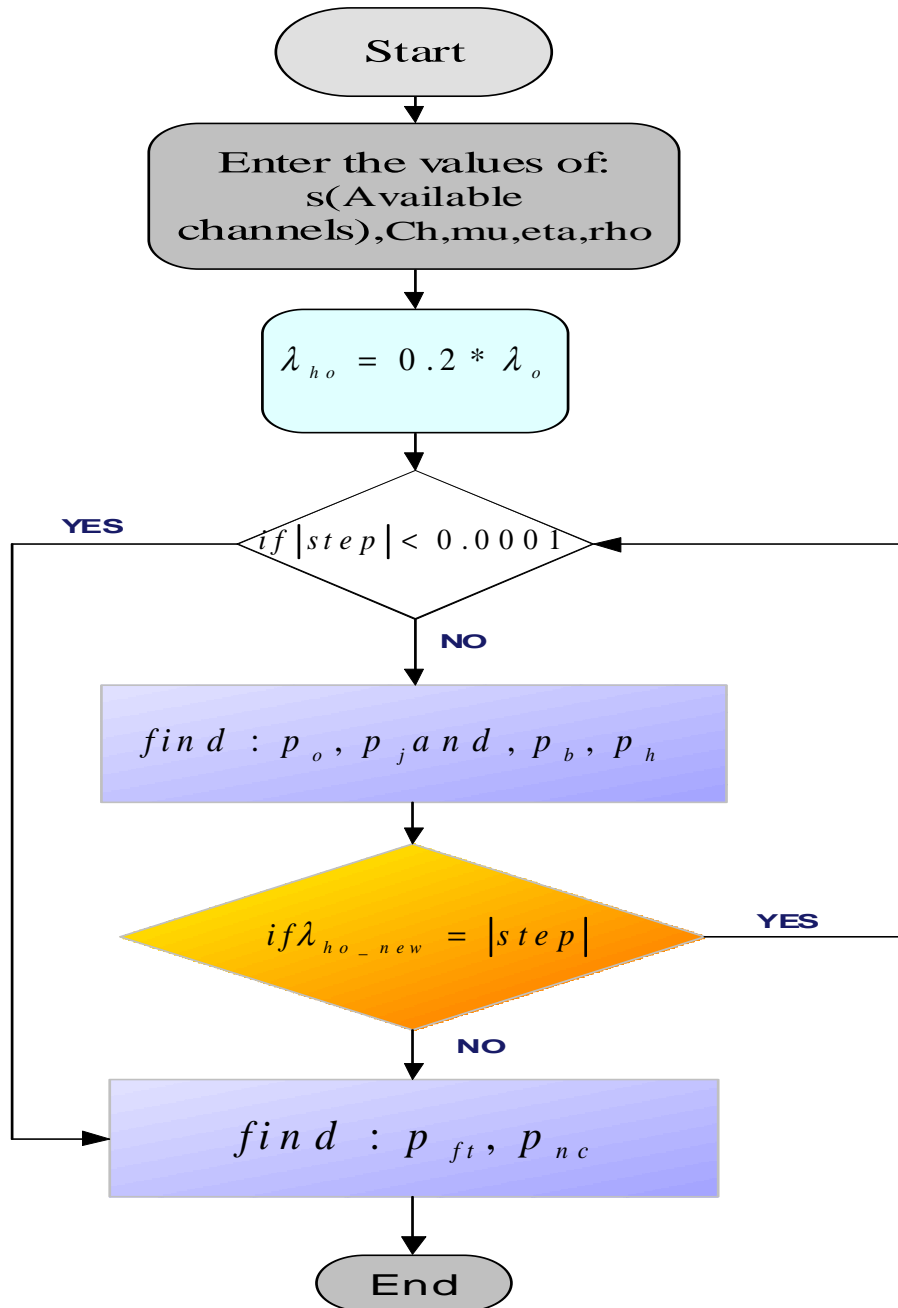
$$P_h = \frac{\left(\frac{\lambda_o + \lambda_{hi}}{\mu + \eta}\right)^s (\lambda_{hi})^{s-n}}{s!} (P_o) \quad (3.21)$$

As,  $s = n + ch$  then  $n = s$  when  $Ch=0$  the Probability of handoff calls drop can be expressed as,

$$P_h = \frac{\left(\frac{\lambda_o + \lambda_{hi}}{\mu + \eta}\right)^s}{s!} (P_o) \quad (3.22)$$

From equation (3.22), we achieved same equation as of NPS handoff probability  $P_h$ .

## 3.3. Call admission control Algorithm flow chart (Guerrero 1999)



### 3.4. Call admission control Algorithm (Guerrero 1999)

To see the performance of system parameters like  $P_b, P_h, P_{ft}, P_{nc}$  have been introduced.

Steps:

*Inputs = s (Available channels), (guard)Ch, mu ,eta, rho*

*Outputs =  $P_b, P_h, P_{ft}, P_{nc}$*

*Step0=  $\lambda_{handoff} = 0.2 * \lambda_{nod}$ ; where,*

*Step1= if  $|step| < 0.0001$  jump step 4 and calculate (pro\_force\_termination) probability  $P_{ft}$  and  $P_{nc}$  (pro\_not\_complete)*

*Step2= calculate  $P_0$  and  $P_j$ , calculate  $P_{block}$ ,  $P_h$ .*

*Step3= find the new value of  $\lambda_{handoff}$  [ $\lambda_{handoffnew}$ ] and also value of  $\lambda_{hi}$  from*

$$\lambda_{hi} = \sum \lambda_{ho\_new}$$

*If difference between the old handoff and new handoff value of  $\lambda_{ho}$  is [step] then jump to step1.*

*Step4 = Find  $P_{ft}$  and  $P_{nc}$ , i.e. force termination probability, call not complete probability respectively.*

#### 4. CELL BASED CALL ADMISSION CONTROL WITH QoS

The target for next generation cellular systems is to provide QoS for multimedia applications. For this purpose, (Nasser et al.2007) propose multiple-threshold bandwidth reservation scheme combined with call admission control Algorithm. The proposed method provides better QoS and efficient utilization of bandwidth in M/M/C/C queuing systems. (Nasser et al.2007)

In this system, (Nasser et al.2007) compute call blocking and dropping probabilities based on Complete Sharing (CS) policy. Next generation cellular systems demand of multimedia services like audio, video conference, Web service with guarantees high data rates and Quality of Service (QoS). To have such high data rates, new broadband wireless systems have introduced. For example, the 3<sup>rd</sup> Generation Partnership Project (3GPP) introduces High Speed Downlink Packet Access (HSDPA) in (3.5G specifications of Release 5) cellular system, which is extension to 3G Universal Mobile Telecommunication System (UMTS). The data rate of HSDPA theoretically support up to 14.4 Mbps, which is seven times more than data rate offered by the 3G Universal Mobile Telecommunications System (UMTS). HSDPA improve the WCDMA performance for downlink packet traffic. The multimedia demand for bandwidth in wireless networks is much more so it is important to allocate system bandwidth efficiently among connections with different QoS requirements. (Laiho et al. 2006:60; Nasser et al.2007)

##### 4.1. Background

In order to achieve higher transmission capacity and better performance, (Nasser et al.2007) divided the total area into small units called cells (microcells or picocells). Thus, pico or micro cells increase handoff rate, which increase handoff dropping rate, thus QoS to the multimedia services is difficult. (Nasser et al.2007) According to (Nasser et al.2007), the problem in cellular supported multimedia wireless system is to

balance objective of both cellular system provider and mobile users. Cellular system provider wants best system utilization so to increase number of users, revenue and later wants to receive better QoS. GoS parameters include Call Blocking Probability (CBP) and Call Dropping Probability (CDP) that we have discussed before in detail.

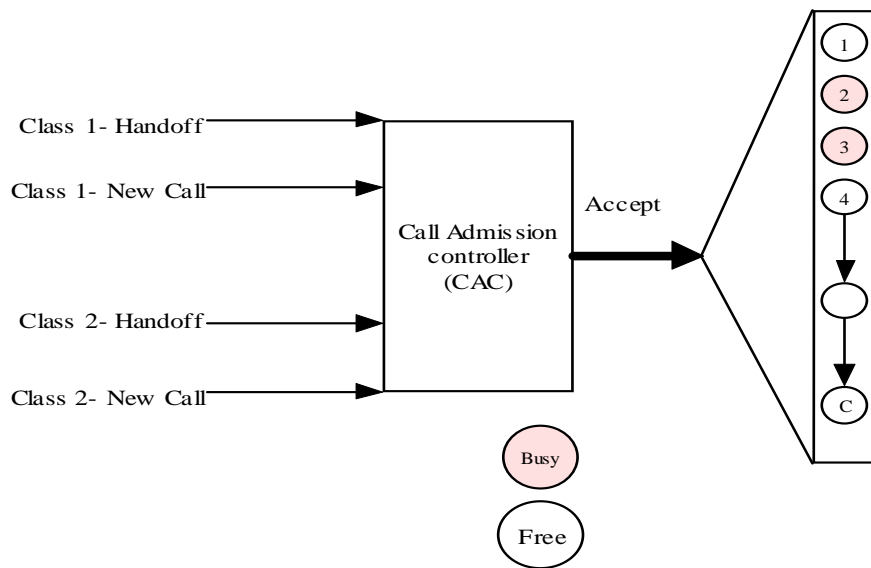
The important goal of QoS is to reduce CDP this can be achieved by reserve bandwidth for handoff mobile users. However, this procedure will increase call-blocking rate of new connections. One should tradeoff between the reduction of CDP and CBP. The Efficient Call Admission Control (CAC) and Bandwidth Reservation (BR) schemes are necessary for desired QoS. In guard channel (GC) scheme, a percentage of the base station's capacity is reserved for handoff calls to maintain the targeted QoS of handoff calls. This decreases the CDP as Lower the CDP, however, this increases probability of new calls blocking. Generally, it is not possible to achieve 0% CDP unless the no of reserve channel is larger than the number of handoff requests. Thus, importance of balance between the user's, level QoS and system utilization increases. Since multimedia connections need different amount of bandwidth to achieve their QoS requirements. Call Admission Control (CAC) and bandwidth reservation (BR) schemes should take action to provide multimedia services and reduce probabilities of call blocking and dropping. (Nasser et al.2007) In (Nasser et al.2007), Nasser proposes call Multimedia Guard Channel (MGC) to achieve better QoS, in terms of CBP and CDP. The Markov birth-death M/M/C/C queuing model provide decision for call admission by mathematical derivation of call blocking probability and call dropping probability for each separate class.

#### 4.2. System model

In (Nasser et al.2007), CAC and bandwidth control is consider in each cell. The correlation between sub-systems called cell, results in handoff connections between the cells, which is an input to each sub-model. Under this assumption, each cell have been modeled and analyzed individually. A similar model used for all cells, but with different

parameters as reflecting index, mobility, traffic conditions, and channel assignment policy. We also assume Fixed Channel Allocation (FCA), which means each cell has fixed capacity. The calculation is based on basic bandwidth units (BBUs) for guarantee desired QoS.

Consider that total capacity of cell is  $C$  BBUs. We have two types of connections in system: *new* connections and *handoff* connections. Class-1 traffic refers to voice service while class-2 traffic is video service. These two separate classes based on bandwidth requirements. Each class- $i$  requires Bandwidth (BW)  $c_i$  BBU ( $i = 1, 2$ ). The classes order increases according to their bandwidth requirements, such that  $c_1 \leq c_2$ . The block diagram of cell admission control is shown in Figure (9).



**Figure 9.** System Model call admission control (CAC) (Nasser et al.2007).

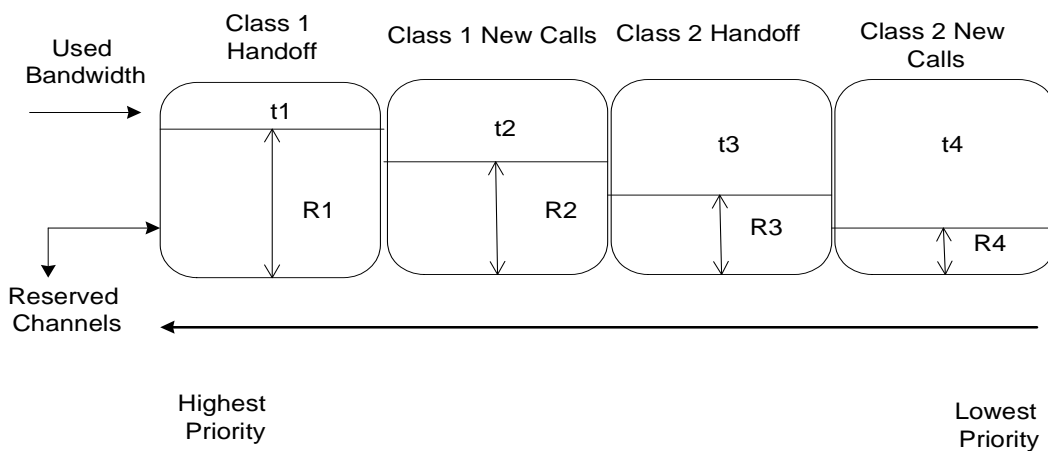
The Connection Admission Control (CAC) algorithm controls whether, the connections have granted to a user or not. First, we discuss bandwidth reservation scheme and then proposed *Call Admission Control (CAC) Algorithm*. According to (Glisic 2006:245) admission control and resource reservation algorithms, requires source traffic characterization and service characterization.



#### 4.2.1. Bandwidth Reservation Scheme

Any bandwidth reservation scheme provides guarantees QoS and low Call Dropping Probability (CDP) due to fixed bandwidth allocation exclusively for handoffs, thus priority given over new connections. However, it seriously decreases Bandwidth Utilization (BU) and cause high Call Blocking Probability (CBP) for new calls. For each service, the QoS targets have to be set and naturally met. QoS specified by speech coverage and blocking probability only (Laiho et al.2006:93). As, (Nasser et al.2007) proposed bandwidth reservation scheme reduces Call Dropping Probability (CDP), Call Blocking Probability (CBP), and improves Bandwidth Utilization (BU) at the same time. In this (Nasser et al.2007), consider two types of traffic in system; one is new calls and other handoff calls these further divided in to four traffic categories: class-1 handoff, class-2 handoff, class-1 new call, and class-2 new call.

To create a balance between CDP and CBP to improve BU in a cell, the (Nasser et al.2007) priority order is as follows: class-1 handoff has highest priority, class-1 new call, class-2 handoff, and finally class-2 new call has the lowest priority in all. The purpose of bandwidth reservation scheme is to reserve different bandwidth to each class. Giving four bandwidth thresholds,  $t_1$ ,  $t_2$ ,  $t_3$ , and  $t_4$  whereas  $(t_1 \leq t_2 \leq t_3 \leq t_4)$  as shown in Figure (10).



**Figure 10.** Priority base bandwidth reservation (Nasser et al.2007).

Either the bandwidth represents the cell bandwidth that is currently in use by new calls or handoff calls. The reserved bandwidth portion reserved for future calls and shared with all type of incoming calls. In reservation scheme  $t_1$ ,  $t_2$ ,  $t_3$ , and  $t_4$  are thresholds for class-1 handoff, class-1 new call, class-2 handoff call, and class-2 new call, respectively. As reserved bandwidth of the corresponding category decreases, the priority level decreases. For example, according to priority assignment for class-1 handoff has highest priority, it means more bandwidth should be reserved for future incoming class-1 handoff connections. It also means if resources equally divided among classes then for highest priority class threshold value 't1' should be smallest.

#### 4.2.2. Call Admission Control (CAC) Algorithm

The call admission control (CAC) algorithm uses threshold values to make the decision of call admit or call handoff reject, this algorithm calculates bandwidth according to the priority level given to arrival call request as follows. As we have two classes then for  $i = 1, 2$ . Let  $C_{nc_i}$  represent total bandwidth occupied by class- $i$  new calls and  $C_{h_i}$  represent total bandwidth occupied by class- $i$  handoff calls. Let  $m_i$  is number of class- $i$  new calls, and  $n_i$  denote is number of class- $i$  handoff calls.

$$C_{nc_i} = m_i c_i \quad (4.1)$$

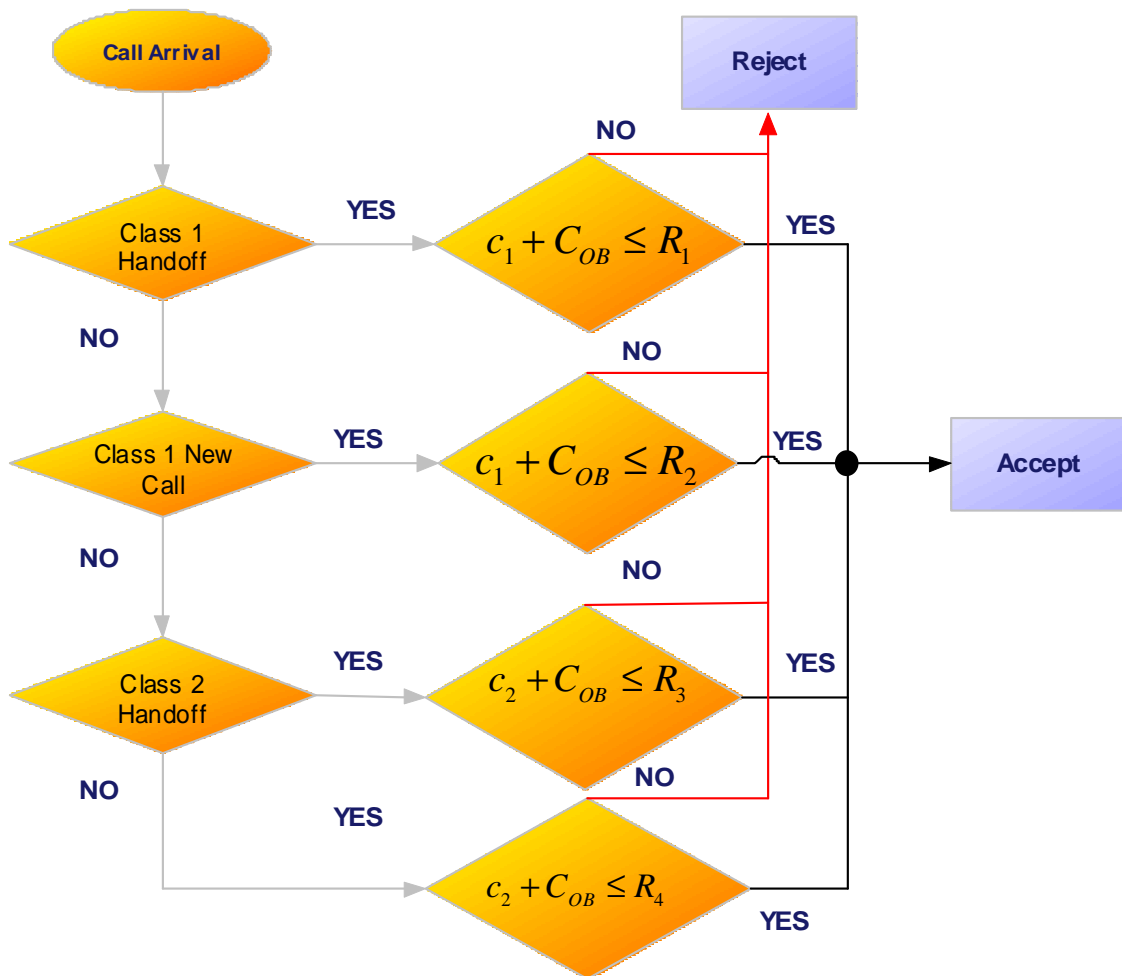
$$C_{h_i} = n_i c_i \quad (4.2)$$

Whereas,  $C_{nc_i}$  = total bandwidth occupied by class- $i$  new calls, and  $C_{h_i}$  = total bandwidth occupied by class- $i$  handoff calls. The total bandwidth occupied in a cell is as follows  $C_{OB}$ , (Nasser et al.2007).

$$C_{OB} = \sum_{i=1}^2 (C_{nc_i} + C_{h_i}) \quad (4.3)$$

For  $i = 1, 2, 3, 4$  the threshold values are  $t_1, t_2, t_3$ , and  $t_4$ , where as if  $c_1 + C_{OB} \leq R_1$  then class-1 handoff call is accepted, if  $c_1 + C_{OB} \leq R_2$  class-1 new call is accepted, if  $c_2 + C_{OB} \leq R_3$  then class-2 handoff call is accepted, if  $c_2 + C_{OB} \leq R_4$  then class-2 new call is accepted.

#### 4.2.3. Cell bases call admission control Algorithm Flow chart



**Figure 11.** Cell bases call admission control Algorithm Flow chart (Nasser et al.2007).

In (Nasser et al.2007) Nasser proposed Multimedia Guard Channel (MGC) scheme based on M/M/C/C queuing system. The steady state probability distribution for

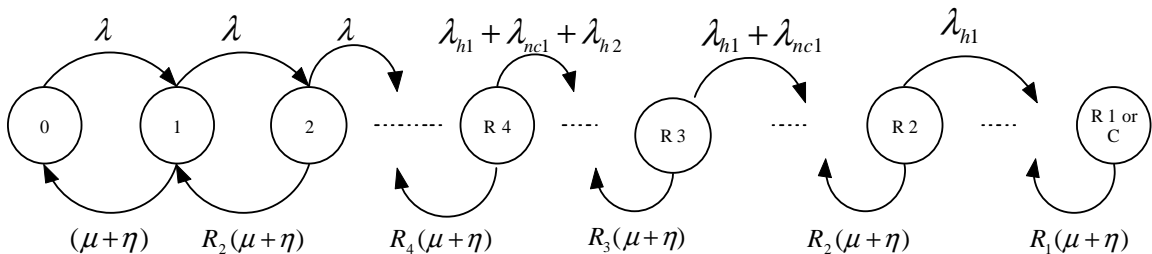
M/M/C/C queuing system gives calls intensity measurements, which used to compute system CBP and CDP.

#### 4.2.4. Assumptions

If bandwidth (BW) totally occupied then the incoming call is blocked or dropped as real-time traffic never buffered. For  $i = 1, 2$ , new call arrivals and handoff call arrivals assumes to follow Poisson process at rates  $\lambda = \lambda_{nc_i} + \lambda_{h_i}$  respectively. The call holding time of a class- $i$  calls follow exponential distribution with mean  $1/\mu_i$ , as  $\mu = \mu_1 + \mu_2$ . The cell residence time (CRT) is the amount of time that a mobile stays in a cell before handoff, is an exponential distribution with mean  $1/\eta_i$ . Call in any class follows the CRT distribution, where  $\eta$  represents the call handoff rate. The channel occupancy time for new calls and handoff calls in class- $i$  traffic is exponentially distributed with means  $1/\mu_{nc_i}$  and  $1/\mu_{h_i}$  whereas,  $\mu_{nc_i} = \mu_{h_i} = \mu + \eta$ .

#### 4.2.5. Analysis and Derivations

The cell follows an M/M/C/C queuing systems in Markovian birth death process with threshold states  $R_j = 1, 2, 3, 4$ , as shown in Figure (12). The state space of a cell is defined as  $\Omega = \{0 \leq x \leq C\}$  and the nonnegative number of ongoing class-  $i$  calls (new and handoff calls) for  $i=1, 2$ . The call blocking  $P_{B_i}$  and dropping,  $P_{D_i}$  probabilities given in Table 1.



**Figure 12.** Markov model for CAC Scheme for data calls guard channel (Nasser et al.2007).

**Table 1.** Blocking/Dropping Probabilities (Nasser et al.2007).

Category	Blocking/Dropping Probabilities
Class-1 handoff	$P_{D_1} = \sum_{j=R_1}^C P_j$
Class-1 new calls	$P_{B_1} = \sum_{j=R_2}^C P_j$
Class-2 handoff	$P_{D_2} = \sum_{j=R_3}^C P_j$
Class-2 new calls	$P_{B_2} = \sum_{j=R_4}^C P_j$

The call arrival rate  $\lambda$  can be expressed as,

$$\lambda = \lambda_{h_1} + \lambda_{nc_1} + \lambda_{h_2} + \lambda_{nc_2} \quad (4.4)$$

Probability  $P_j$  of the states for  $0 \leq j < C$  in terms of  $P_0$  is as follows (Nasser et al.2007).

$$P_j = \begin{cases} \frac{\left(\frac{\lambda}{(\mu + \eta)}\right)^j}{j!} P_0 & \text{For } 0 \leq j < R_4 \\ \frac{(\lambda_{h_1} + \lambda_{nc_1} + \lambda_{h_2})^{j-R_4} (\lambda)^n}{j! (\mu + \eta)^j} P_0 & \text{For } R_4 \leq j < R_3 \\ \frac{(\lambda_{h_1} + \lambda_{nc_1})^{j-R_3} (\lambda_{h_1} + \lambda_{nc_1} + \lambda_{h_2})^{R_3-R_4} (\lambda)^n}{j! (\mu + \eta)^j} P_0 & \text{For } R_1 \leq j < R_2 \\ \frac{(\lambda_{h_1})^{j-R_2} (\lambda_{h_1} + \lambda_{nc_1})^{R_2-R_3} (\lambda_{h_1} + \lambda_{nc_1} + \lambda_{h_2})^{R_3-R_4} (\lambda)^n}{j! (\mu + \eta)^j} P_0 & \text{For } R_1 \leq j < C \end{cases} \quad (4)$$

Whereas, initial probability is expressed as,

$$\begin{aligned}
 P_0 & \qquad \qquad \qquad (4.6) \\
 &= \left[ \sum_{j=0}^{R_4} \frac{\left(\frac{\lambda}{(\mu + \eta)}\right)^j}{j!} \right. \\
 &+ \sum_{j=R_4+1}^{R_3} \frac{(\lambda_{h_1} + \lambda_{nc_1} + \lambda_{h_2})^{j-R_4} (\lambda)^j}{j! (\mu + \eta)^j} \\
 &+ \sum_{j=R_3+1}^{R_2} \frac{(\lambda_{h_1} + \lambda_{nc_1})^{j-R_3} (\lambda_{h_1} + \lambda_{nc_1} + \lambda_{h_2})^{R_3-R_4} (\lambda)^j}{j! (\mu + \eta)^j} \\
 &\left. + \sum_{j=R_2+1}^C \frac{(\lambda_{h_1})^{j-R_2} (\lambda_{h_1} + \lambda_{nc_1})^{R_2-R_3} (\lambda_{h_1} + \lambda_{nc_1} + \lambda_{h_2})^{R_3-R_4} (\lambda)^j}{j! (\mu + \eta)^j} \right]^{-1}
 \end{aligned}$$

Consider that, total cell capacity is ‘C’ basic bandwidth units (BBU) with two types of real time traffic voice and video. The voice BW is  $c_1$  and video is  $c_2$ , where  $c_1 \leq c_2$ . The call arrival process is poisson process in which new calls of both classes arrive with rate  $\lambda = \lambda_{nc_1} = \lambda_{nc_2}$  (Calls/sec/cell). The Call Holding Time (CHT) is exponential distribution with mean  $1/\mu$ . Note that  $\mu = \mu_1 = \mu_2$ .

#### 4.2.6. Performance measurements Parameters

The offered traffic is call arrival rate the performance measurement based on call blocking, dropping probabilities and bandwidth utilization (BU). First case we determine the impact of non sharing policy and then complete sharing policy (CSP) such that the call admission for class-i only admit the call whenever there is BW to accommodate the call.

### 4.3. Discussion

To ensure the quality of service (QoS), Call admission control (CAC) and bandwidth reservation plays significant role in cellular system. Traditionally guard channel scheme used for single traffic type this chapter goal is to make go beyond to multi-class, multi channel resource utilization by reducing call blocking and dropping. Our next chapter model is to develop Adaptive CAC based on mobility and traffic volume.

## 5. POWER BASED ADMISSION CONTROL

In WCDMA standard, both the uplink and downlink needs power control management. When a call initiate in cell, it adjusts its transmission power based on the received common pilot signal power. The ideal power at every receiver should be constant. The path loss between the UE and the base station is estimated using pilot signal power. The stronger the received common pilot power, the less initial transmission power is needed. This type of initial power adjustment is made by *uplink open-loop power control*. In Open loop power control (OLPC) mainly focuses on adjustment of uplink of the communication. (Laiho et al. 2006:28) The WCDMA has fast closed loop power control in both uplink and downlink, used to improve system capacity. In this case, BS commands MS to increase or decrease its power to maintain the targeted QoS. The BS takes its decision based on the Received SIR. Bit error rate or block error rate determine the target SIR. To reduce error rate, the target SIR is increased until achieve affordable error rate. The closed-loop power control adjusts the transmission power of the transmitter until the target SIR is reached. The target SIR is controlled by the *outer-loop power control*. (Laiho et al.2006) When a call originates in a system it requires resources like CDMA codes and power and thus creates additional interference in system existing users. CDMA use soft handoff (make before break), Soft handoff has the disadvantages in terms of system complicity and additional resource requirement. Researchers have proposed different schemes to maximize macro diversity gain to minimize handoff failure.

### 5.1. Radio Link Performance Indicators

The radio network dimensioning and planning in WCDMA link improves performance of radio network. The link performance indicators measure channel condition of BTS and UE using channel simulator. The signal quality is specified as “*The level at which 75% of users state that the voice quality is either good or excellent in 90% of service area*” (Hammuda 1997:162). The receiver and transmitter algorithms of the simulation models must be as realistic as possible. One way to achieve this is to require at least



compliance with the link performance requirements. The “Assumptions regarding the radio propagation channel must be carefully chosen, as the propagation channel has a significant effect on the link performance indicators thus speed of the UE must be taken into account” (Laiho et al.2006:75).

According to (Laiho et al. 2006), received signal code power indicate the received power of the Common Pilot Channel (CPICH) as measured by the UE and used to estimate the path loss. The UE transmit power is important to verify power control performance, to estimate the Targeted SIR and BLER. (Laiho et al.2006:90) The power receives at BS for line of sight (LOS) is as follows, (Garg 2007:49).

$$P_r = P_t \left( \frac{\lambda}{4\pi d} \right)^2 G_b G_m$$

Whereas,  $P_t$ = transmit power,  $d$ =distance ,  $G_b$ = gain of BS antenna,  $G_m$ =gain of mobile antenna,  $\lambda$  =wave length.

#### 5.1.1. The Propagation Problem

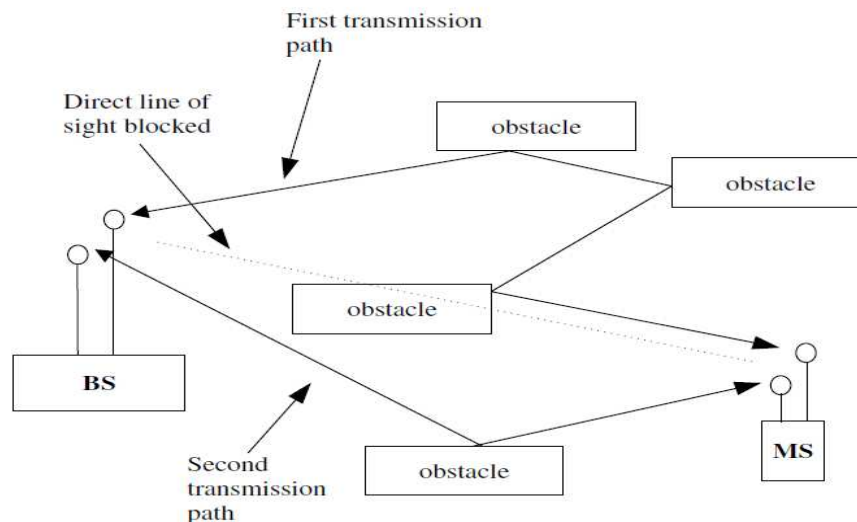
The propagation path loss increases with increase in frequency and distance between base station and mobile. Propagation models should be able to estimate radio wave propagation as accurately as possible. Different models have created for different environments to predict the path loss between the transmitter and receiver to maximize received power transmitted by BS. (Mishra 2007:40) Fixed station (FS) and mobile stations (MSs) moving through the cell. The cell is usually assumed as a hexagon in shape, although its propagation profile is more like a circle with the fixed station in its center. Cell radii vary from meters in heavily built-up urban areas to 30 km somewhat more in rural areas. The wave propagation models include factors like Line of sight (LOS) between transmitter and receiver, mobility of user cause Doppler shift, the position of user in serving area causes shadowing and building obstacle causes multipath problems also called fading and delay spread. The short wave fading called Rayleigh fading the most severe kind of fading. (Freeman 2007:509; Laiho et al.2006:94; Lee 2006:39-40)

## 5.2. System Model

Once the maximum allowed propagation loss in a cell is known, it is easy to apply any propagation model for cell range estimation. The “Macro cellular radio propagation have been roughly characterized by three nearly independent phenomenon’s; path loss variation with distance, slow log-normal shadowing, and fast multipath fading” (Stüber 2002:20).

### 5.2.1. Propagation Models

As antenna of MS is low, it is difficult to make LOS with BS antenna. Propagation model should be selected in such a way that it helps to model the effects of obstacles and reflecting objects. (Sauter 2006:289). Different formulas for path loss have been introduced some have force-out frequency factor like *ITU-R Formula* for broadcasting, *British Urban Path Loss Formula* proposed by *Allesbrook and Parsons*. *Okumura* carried out a detailed analysis for path predictions around Tokyo for mobile terminals published an empirical formula based on Okumura’s results to predict path loss. (Freeman 2007:510-511)



**Figure 13.** Path loss effect in Urban Area (Sauter 2006).

### 5.2.2. Free space path loss (FSL)

Free space path loss (FSL) is a function of the square of the distance and the square of the frequency plus a constant. FSL formula is a very useful formula if the strict rules of obstacle clearance are obeyed but unfortunately, it is not possible to obey rules due to transmission path loss effect for building hills and atmospheric condition. The (FSL) equation can be expressed as, (Freeman 2007:3,509; Mishra 2007:40; Garg 2007:51)

$$L(\text{free}) = 32.4 + 20\log_{10}(f_c)\text{MHz} + 20\log_{10}(d)\text{Km} \quad (5.1)$$

### 5.2.3. Okumura Model

Okumura propagation model is famous for signal strength estimation, Cell Range and Cell Coverage Area Estimation. It can support carrier frequencies up to 3000 MHz's. This model gives us path loss of signal of BS and MS in terms of distance. The Okumura model support distance between BS and MS up to 100 km and receiver (Rx) height " $h_m$ " is between 3 to 10 m. The transmitter (Tx) height " $h_b$ " is between 30 to 200 m. Okumura model path loss equation have been calculated as, (Laiho et al.2006:126; Mishra 2007:51; Garg 2007:67; Freeman 2007:511)

$$Lp(d) = 69.5 + 26.1\log_{10}(f_c) - 13.8\log_{10}(h_b) - \alpha(h_m) + (44.9 - 6.55\log_{10}(h_b)) \log_{10}(d) \quad (5.2)$$

Correction factor for mobile antenna height given by  $\alpha(h_m)$  as,

$$\alpha(h_m) = [1.1 \log_{10}(f_c) - .7]h_m - [1.56\log_{10}(f_c) - 0.8] \quad (5.3)$$

Whereas,  $f_c \geq 400$  MHz's.

#### 5.2.4. SUI Model

The SUI model developed by Stanford University called Stanford University Interim (SUI). It has accommodate frequency greater than 1900 MHz's The WiMAX may use frequencies above 3500 MHz, which increase the need of SUI model. In this propagation model, Sun (Sun 2007) have shown path loss for different areas type called terrains but in this case, we show path loss in SUI only for Terrain A (Hilly with heavy tree densities) with highest path loss, the region is very dense and populated. The pathloss equation in SUI path loss is as follows, (Sun 2007).

$$PL_{SUI} = A + 10\gamma \log_{10} \left( \frac{d}{d_0} \right) + X_f + X_h + S \quad (5.4)$$

Here,  $PL_{SUI}$  = Path Loss (dB),  $d$  is distance between MS and BS,  $d_0$  is reference distance equals to 100m for outdoor,  $X_f$  is frequency Correction factor,  $X_h$  is BS height Correction factor,  $S$  is Shadowing (use only in flat ruler areas),  $\gamma$  = Path loss

$$\gamma = a - bh_b + \frac{c}{h_b} \quad (5.5)$$

Whereas,  $h_b$  = BS height and value of  $a$ ,  $b$  and  $c$  (terrain A) parameters. we are using terrain A for these specific results.

$$A = 20 \log_{10} \left( \frac{4\pi d_0}{\lambda} \right) \quad (5.6)$$

Where  $A$  = path loss for free space while  $d_0$  = 100m is the reference distance between MS and BS and  $\lambda$  = wavelength = 0.025. The frequency correction factor can be expressed as,

$$X_f = 6 \log_{10} \frac{f}{2000} \quad (5.7)$$

Here,  $f$  is the frequency in MHz's, The BS height Correction factor  $X_h$  is expressed as,

$$X_h = -10.86 \log_{10} \left( \frac{h_r}{2000} \right) \quad (5.8)$$

Where 'hr' is the MS height. For urban highly populated areas  $X_h$  can be expressed as,

$$X_h = -20 \log_{10} \left( \frac{h_r}{2000} \right) \quad (5.9)$$

$$S = 0.65(\log_{10} f)^2 - 1.3 \log_{10} f + \beta \quad (5.10)$$

Here, for rural and suburban area  $\beta = 5.2$  dB.

### 5.3. Load Factors in uplink and downlink Radio Link Budgets

Average capacity of the system has estimated through load equation and noise rise in system. In order to estimate the load we need to define the  $\left(\frac{E_b}{N_o}\right)$  of each connection. It defined as required bit energy per noise spectral density. (Holma and Toskala 2004:191)

$$\left(\frac{E_b}{N_o}\right)_j = PG \cdot \frac{\text{signal power of user } j}{\text{Total recieved power} - \text{signal power of user } j} \quad (5.11)$$

Where  $PG$  is processing gain, the spreading consists of two operations. The first is the channelization operation, which transforms each data symbol into a number of chips, thus increasing the bandwidth of the signal. The processing gain is the ratio of the WCDMA chip rate ( $W$ ) which is 3.84 M chip/s and data rate, also called spreading factor. The second operation is the scrambling operation, where a scrambling code applied on top of the spread signal. To estimate the maximum range of a cell the radio link budget, calculation is needed. The output of the radio link budget calculation is the maximum allowed propagation path loss, which in return determines the cell range and thus the number of sites needed. (Laiho et al.2006:69, 95)

### 5.3.1. Uplink Radio Link Budget

The interference is a function of cell loading. As more users are allowed in the system, a larger interference margin is needed in the uplink and the coverage area shrinks. The uplink load factor has derived as following, for simplicity the derivation is performed with service activity  $v_j=1$ . The voice activity factor is  $v_j$ , then Processing gain is  $PG = \frac{W}{v_j \cdot R_j}$ , and  $R_j$  is bit rate. The load factor of one connection can be written as, (Koivo H., Elmusrati M. 2009:228; Holma and Toskala 2004:191; Laiho et al.2006:96)

$$L_j = \frac{1}{1 + \frac{W}{\left(\frac{E_b}{N_o}\right)_j \cdot v_j \cdot R_j}} \quad (5.12)$$

Where,  $E_b/N_0$ = signal to noise ratio,  $W$ = chip rate,  $v$  = activity factor and  $R$  = data rate. The uplink load factor for all the users is as follows,

$$\eta_{j,ul} = \sum_{j=1}^N L_j = \frac{1}{1 + \frac{W}{\left(\frac{E_b}{N_o}\right)_j \cdot v_j \cdot R_j}} \quad (5.13)$$

When system reaches its pole capacity uplink load factor  $\eta_{j,ul}$  goes to unity and the corresponding noise rise  $NR_j$  approaches infinity. As  $i$  is the other-to-own cell interference ratio  $i = \frac{\text{Other cell interference}}{\text{Own cell interference}}$  then sum of all load factors of  $j$  users in system is as follows, (Holma and Toskala 2004:192,261)

$$\eta_{j,ul} = (1 + i) \sum_{j=1}^N L_j = (1 + i) \sum_{j=1}^N \frac{1}{1 + \frac{W}{\left(\frac{E_b}{N_o}\right)_j \cdot v_j \cdot R_j}} \quad (5.14)$$

### 5.3.2. Downlink Radio Link Budget

Downlink dimensioning has same logic as for uplink. For a particular cell total BS transmits power estimation is needed. If power exceeded the required QoS guaranteed, either the cell range should be limited or the number of users in a cell should reduce. (Laiho et al.2006:96) The downlink load factor as follows, (Holma and Toskala 2004:264)

$$\eta_{j,DL} = \sum_{j=1}^N \frac{v_j \left(\frac{E_b}{N_o}\right)_j}{\frac{W}{R}} [(1 - \alpha_j) + i_j] \quad (5.15)$$

Average downlink load factor gives the prediction of number of user in system can be written as,

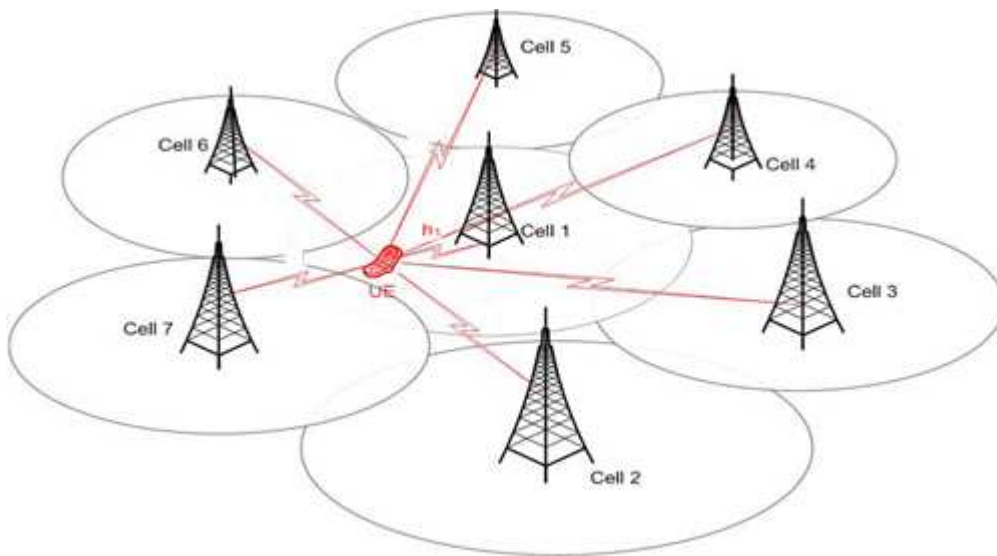
$$\overline{\eta_{j,DL}} = \sum_{j=1}^N \frac{v_j \left(\frac{E_b}{N_o}\right)_j}{\frac{W}{R}} [(1 - \overline{\alpha_j}) + \overline{i_j}] \quad (5.16)$$

$\alpha_j$  the orthogonality factor in the downlink of user  $j$  . WCDMA uses orthogonality in the downlink to separate the users, as 1 corresponds to perfectly orthogonal users. The average downlink orthogonality is estimation based on the multipath propagation in the uplink. Typically, the orthogonality is between 0.4 and 0.9 in multipath channels. (Holma 2004:264)

### 5.3.3. Pilot Power Adjustment

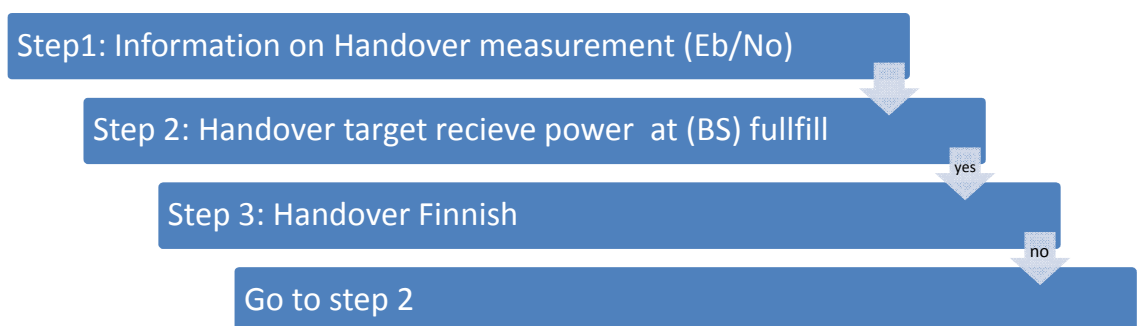
Common Pilot Channel power allocation is another important task in WCDMA network design. Optimum pilot powers graph ensure maximum coverage with minimum interference to neighboring cells. Excessive pilot powers take maximum proportion of the total available BS transmission power so that not enough power left for traffic

channels. Typically, 5% of the total base station power allocated to pilot channel, and same amount to other common channels. If a case, where a mobile receive numerous pilots with relatively equal signal strengths, then a particular pilot signals which is dominant enough to enable the mobile to start a call takes the request. Pilot coverage from neighboring BSs must overlap in cell border areas to accommodate handoffs. Receiving the number of pilot signal has decrease capacity and QoS thus referred as an obstacle in network planning. (Laiho et al.2006:180-182)



**Figure 14.** Power receive from in 7 cell sector

Handoff criteria measure signal strength from all receiving BS is



**Figure 15.** Handoff process.



#### 5.4. Measurement of Air Interface Load and CAC Schemes

WCDMA systems uplink and downlink are a separate task that is why congestion control done separately for both links. Two different approaches are used for measuring the load of the air interface. The first load calculation via received and transmitted wideband power and second based on bit rates allocated to each user. The objective mathematical model of call admission control (CAC) in WCDMA network is to drive admission control models. We are focusing on call admission algorithms firstly through wideband power based (WPB) call admission control, secondly through throughput based (TB) call admission control and last is adaptive call admission control (ACAC) algorithm.

##### 5.4.1. Wide Band Power Based (WPB) Admission Control

When a new call arrives, admission control calculates impact on system and decide either to accept new request or reject. If the new call, degrade the quality of service and cause coverage area reduction up to a certain threshold level the system block the call, otherwise accept. The required quality of service has three parameters, maintain required SIR, inter cellular interference, intra cellular interference. (Islam 2008) From equation (5.11)  $\left(\frac{E_b}{N_o}\right)_j$  can be written as,

$$\left(\frac{E_b}{N_o}\right)_j = PG \frac{P_j}{I_{rx Total}} \quad (5.17)$$

Where,  $P_j$ =receive power of a user at BS;  $I_{rx Total}$ = Interference caused by the mobile stations plus thermal noise. The interferences caused by MS should have certain threshold for uplink and downlink to accepting a new call. In uplink  $I_{rx Total}$  should be, (Islam 2008; Holma 2004)

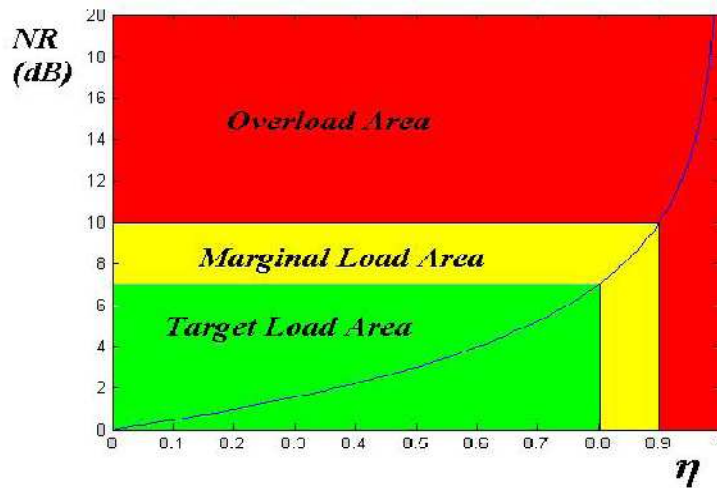
$$I_{rx Total} < I_{rx Threshold} \quad (5.18)$$

The equation of total received power as follows, (Laiho et al.2006:233; Holma and Toskala 2004:265)

$$I_{rx\ Total} = I_{own} + I_{other} + N_j \quad (5.19)$$

$$NR_j = \frac{I_{rx\ Total} - I_{own} - I_{other}}{N_j} = \frac{1}{1 - \eta_{j,ul}} \quad (5.20)$$

Where, Noise rise (NR<sub>j</sub>) is due to one new call admission. (Holma 2004; Laiho et al.2006), interference  $I_{own}$  is the received power from users in the own cell,  $I_{other}$  comes from users in the surrounding cells and  $N_j$  represents the total noise power, including background and receiver noise.

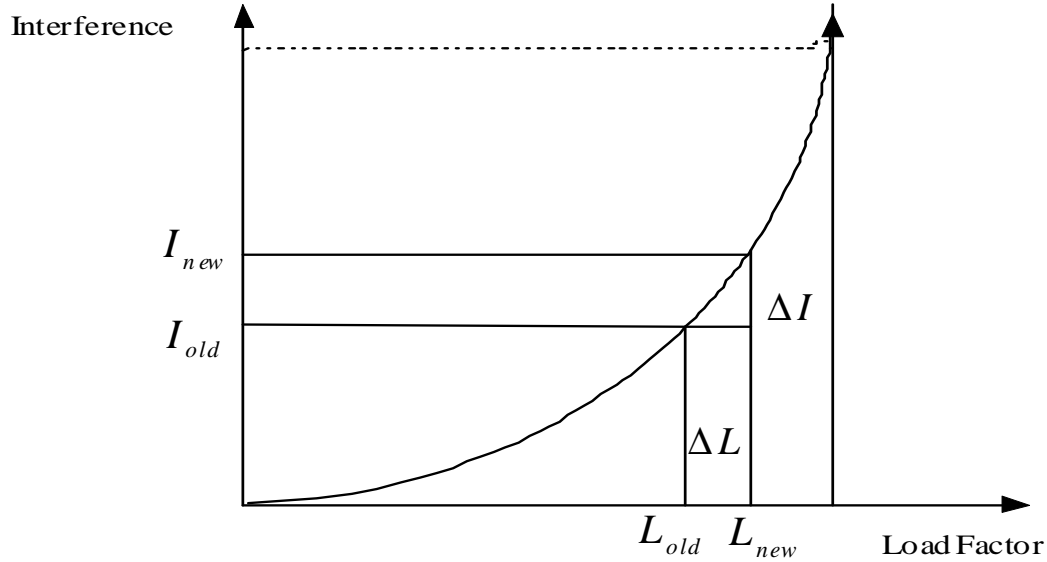


**Figure 16.** Graph between uplink load factor and noise rise.

In Figure (16), as the uplink load factor increase noise rise (NR)dB increases from Targeted load to over load area. Every time a new user seeks admission cause some interference to the system in uplink (Subramanian et al. 2005; Islam 2008) The interference before admitting the new call is  $I_{Total}$  and can be expressed as,

$$I_{Total} + \Delta I \leq I_{rx\ Threshod} \quad (5.21)$$

The new call in system is accepted only when,  $(I_{Total} + \Delta I)$  caused by the new call is less than the threshold value  $I_{rxThreshod}$ .



**Figure 17.** Uplink load curve and the estimation of the load increase due to a new UE (Holma and Toskala 2004:265; Islam 2008).

In Figure (17), the relation between load factor and interference has showed. As  $I_{old}$  = Interference before admitting new call,  $I_{new}$  = expected new interference cause after admitting new call,  $I_{rxThreshod}$  =The maximum interference the system accepts. On the other hand,  $L_{old}$  = The load before admitting new call in system at any instant,  $L_{new}$  =After new call estimated load,  $\Delta I$  = interference caused by the new call, where as  $I_{Total\_old} + \Delta I$ . Whereas, connection is based on difference between previous interference and new interference the uplink criteria .The load change due to single connection is as follows, (Subramaniam et al. 2005; Holma 2004:265; Islam 2008)

$$\Delta L = \frac{1}{1 + \frac{W}{\left(\frac{E_b}{N_o}\right)_j \cdot v_j \cdot R_j}} \quad (5.22)$$

The downlink admission control strategy is the same as in the uplink, i.e. the MS is accepted, if total downlink transmission power is within predefined target value. The load increase depends on initial power that depends on distance between the BS to the mobile. (Subramaniam et al. 2005; Islam 2008).

$$P_{Total\_old} + \Delta P_{Total} > P_{Threshod} \quad (5.23)$$

Where  $P_{Total\_old}$  =The power transmitted before new call,  $\Delta P$  =expected transmission power required for the new call,  $P_{Threshod}$  =Threshold value set by radio network. The power increase  $\Delta P_{Total}$  is calculated through initial power and it depends on the distance between user and BS and determined by the open loop power control. (Subramanian et al 2005; Holma 2004:267; Islam 2008)

#### 5.4.2. Throughput Based (TB) Admission Control

Throughput based (TB) CAC take decision on bases of current load. The threshold values is set for uplink and downlink. For Uplink TBCAC if a new requesting UE is admitted into the radio access network it should full fill  $\eta_{j,ul} + \Delta L > \eta_{j,ul,Threshod}$  simarlary, for downlink  $\eta_{j,dl} + \Delta L > \eta_{j,dl,Threshod}$  where  $\eta$  = Load before admitting new user,  $\Delta L$  =predictable load ,  $\eta_{Threshod}$  =Threshold value for the uplink load factor. The new user is rejected, only when new total load increase by uplink threshold value otherwise accepted. (Subramanian et al 2005; Holma 2004; Islam 2008) If we add one terminal in UL then load factor is given as,

$$\eta_{j,ul,new} = \eta_{j,ul} + \Delta L = \eta_{j,ul} + \frac{1}{1 + \frac{\left(\frac{E_b}{N_o}\right)_{j+1} \cdot v_{j+1} \cdot R_{j+1}}{W}} \quad (5.24)$$

Whereas, downlink load can be expressed as,

$$\eta_{j,dl} = \frac{\sum_{j=1}^n R_j}{R_{max}} \quad (5.25)$$

Where  $n$  is the total number of connection,  $R_j$  = bit rate of user  $j$  and  $R_{max}$  = allowed maximum data rate. The base of WPB and TB schemes is to study the performance of voice and data users. (Islam 2008)

According to (Subramanian et al. 2005), WPB is better in reduction of voice blocking probability and TB has better performance in data call blocking probability reduction. The voice user required low power to be reached then data users hence WPB is more power limited in downlink, which is a bottleneck for data user in WPB. On the other hand, TB in uplink is capacity limited so it works well with data users because results shows data users are less in number then voice users hence uplink form a bottleneck for voice users. (Subramanian et al. 2005)

#### 5.4.3. Adaptive Call Admission Control

The Adaptive Call Admission Control gives us an opportunity to combine wideband power based admission control and the throughput based admission control algorithms. As results shows that wideband power based admission control works well with voice calls. On the other hand, throughput based admission control algorithms works well with data Calls (Subramanian et al. 2005; Islam 2008). As mansion, voice call blocking probability have reduced by Wide Band Power Based (WPB) Admission Control (WPBCAC) and the data call blocking probability reduced by using Throughput Based (TB) Admission Control (TBCAC). On these results, adaptive call admission control utilizes WPBCAC together with TBCAC depending on system requirements and current number of users in the system. The continuous updates by BS about the Total number of users the system switches between WPB and TB according to need by calculating number of each type of users present after last complete call. If voice users are more then Adaptive Call Admission Control switches to WPB. On the other hand, if data users are in large quantity in particular cell it switch to TB scheme. We have two parameters  $\alpha$  and  $\beta$ ,  $\alpha$  predict number of call in coming period and  $\beta$  has data of total

number of calls initiate in the system from start.  $\alpha$  and  $\beta$  fluctuate between 0 and 1. Following equations determined forecast number of calls arrives in the system. (Subramanian et al. 2005; Islam 2008)

$$\hat{V}_{n+1} = \alpha V_n + (1 - \alpha)\hat{V} + \beta V_{total} \quad (5.26)$$

$$\hat{D}_{n+1} = \alpha D_n + (1 - \alpha)\hat{D} + \beta D_{total}$$

$\hat{V}_{n+1}, \hat{D}_{n+1}$  = forecasted number of voice/data calls arrival in the coming period

$V_n, D_n$  = Originated number of voice /data calls in the previous period

$\hat{V}, \hat{D}$  = Forecasted number of voice/ data calls in the previous period

$V_{total}, D_{total}$  = Total number of voice, data calls originate in system since startup

In a system, we have  $m$  channels when  $(m-k)$  channels are busy by following equation. (Subramanian et al. 2005)

$$\beta(m, k) = \frac{\beta(m-1, k-1)}{1 + \frac{1}{m} \sum_{r=0}^{R-1} A_r b_r \beta(m-1, b_r-1)} \quad (5.27)$$

Where  $R$ = the number of traffic classes (0- $R-1$ ), we have  $R-1$  classes in this system with  $R-1$  having the highest priority and 0 the lowest,  $b_r$  = Required data rate,  $m$  = Number of servers in the system as,  $k > 0$  Where offered traffic can be expressed as,

$$A_r = \frac{\lambda_r}{\mu_r} \quad (5.28)$$

The initial values of  $\beta$  when  $k = 0$  measured by the following equations. (Subramanian et al. 2005)

$$\beta(m, 0) = \frac{\frac{1}{m} \sum_{r=0}^{R-1} A_r b_r \beta(m-1, b_r-1)}{1 + \frac{1}{m} \sum_{r=0}^{R-1} A_r b_r \beta(m-1, b_r-1)} \quad (5.29)$$

Using the Erlangs's loss formula ( $M/M/n/n$ ) the loss probability of highest priority class  $R-1$  can be expressed as,

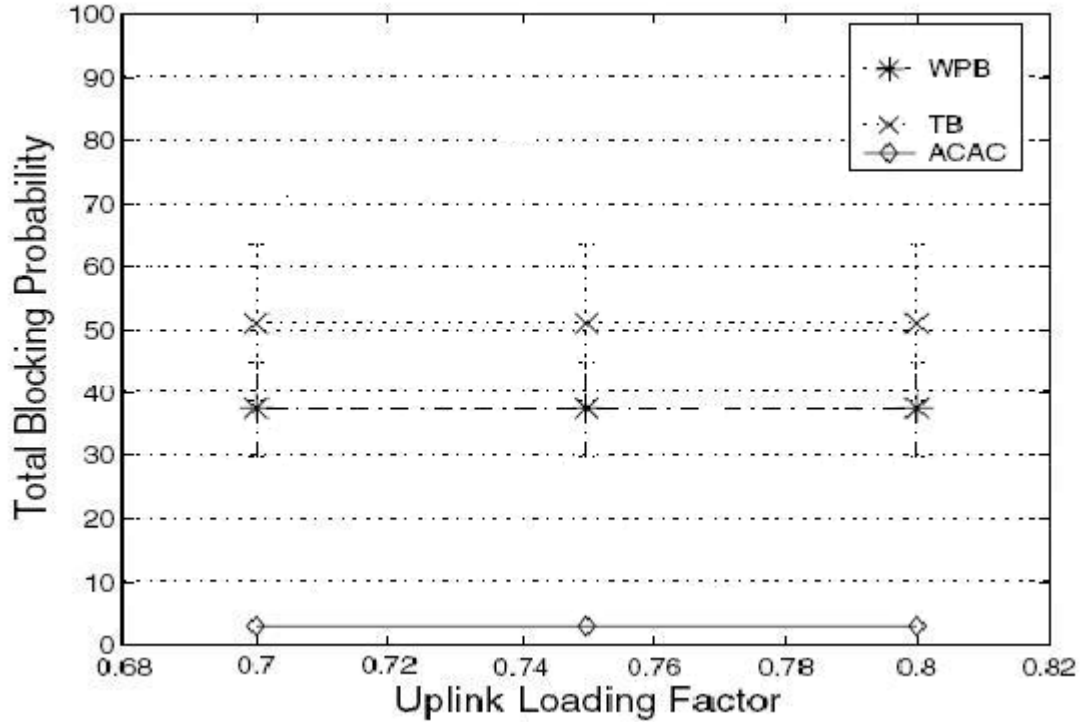
$$P_{b_{R-1,i}} = \beta(n, \rho_{R-1,i}) = \frac{\left(\frac{\lambda}{\mu}\right)^n}{n!} = \frac{(A)^n}{n!} \quad (5.30)$$

$$\frac{\left(\frac{\lambda}{\mu}\right)^i}{\sum_{i=0}^n \frac{\left(\frac{\lambda}{\mu}\right)^i}{i!}} \quad \frac{(A)^i}{\sum_{i=0}^n \frac{(A)^i}{i!}}$$

Whereas, offered traffic  $A$  is as follows, (Subramanian et al. 2005)

$$A = \rho_{R-1} \cdot n, \text{ and } \rho_{R-1} = \lambda_{R-1} / (\mu_{R-1} \cdot n) \quad (5.31)$$

In a scenario where there is dominant number of voice and data users ACAC gives us tremendous improvement in performance upto total blocking probability  $3.1 \pm 0.05$ . (Subramanian et al. 2005)



**Figure 18.** Uplink load factor and blocking probability in WPB, TB, and ACAC (Islam 2008; Subramanian et al. 2005)

### 5.5. ACAC in Multi-Class through fuzzy logic for congestion control

Fuzzy logic systems have been successfully applied to deal with traffic-control-related problems and provide a robust mathematical framework for dealing with real world imprecision. Fuzzy sets, attempt to make system complexity manageable. The *network resource estimator* does the accounting for system-resource usage. Limited spectrum resource and mobility of users degrade quality of service (QoS) in wireless networks. The terms used to describe the cell loss ratio, which is one of the dominant QoS requirements, are “Satisfied” and “Not Satisfied”. Second main issue is network congestion control that remains a critical issue and a high priority, especially in the growing size, demand, and speed (bandwidth) of the increasingly integrated services networks. Adaptive call admission control scheme (ACACS) for multi-class services in wireless networks contain adaptive fuzzy service degradation control model (FSDCM),



and optimal service degradation allocation model. The calculation of handoff call dropping probability and new call blocking probability based on queuing model. Each class of service competes for bandwidth resources with a certain probability, which is proportional to its priority coefficient. The main idea is to adapt an adaptive fuzzy service degradation control model (FSDCM) that degrades the existing services in the system, in order to release appropriate amount of resources to admit more handoff calls. The degradation is according to handoff call dropping probability. (Hongwei 2008; Ma et al. 2005; Pedrycz et al. 2001, 55-70)

One of the major goals of 4G systems is to provide mobile users with wireless multimedia services anywhere and anytime. Different types of services may have inherently different Quality of Service (QoS) constraints in terms of handoff call dropping probability,  $P_{drop}$ , new call blocking probability,  $P_{block}$ . To this end, efficient wireless resource management and call admission control (CAC) schemes have to be established. We use  $P_{drop}$  and  $P_{block}$  to monitor the QoS level of a specific service type. The whole multi-class CAC scheme abstracted of a closed-loop feedback control system. (Hongwei et al. 2008) introduced *Service differentiation vector* to provide an overall frame to characterize and differentiate different classes of services. Fuzzy service degradation controller dynamically degrades the existing services in the system when the system resource becomes scarce, seeking a trade-off between network resource utilization and user satisfaction. (Pedrycz et al. 2001)

### 5.5.1. Mathematical model of system services

Mathematical model uses Poisson process to describe the new call arrival and handoff call arrival of a certain class of service as previous modes in chapter 3 and 4 when we have complete knowledge of available resources. As mentioned in chapter 2, 3, and 4, we assume that the average service times by average channel holding times, of new call and handoff call are both exponentially distributed. Suppose that there are totally  $J$  classes of services in the system. Thus, for a certain service type  $k$ ,  $k = 1, 2, \dots, J$ , its new call arrival rate and handoff call arrival rate can be denoted by  $\lambda_{new}(k)$  and  $\lambda_h(k)$ ,

respectively. The average service times of its new call and handoff call can be denoted by  $\frac{1}{\mu_{new}(k)}$  and  $\frac{1}{\mu_h(k)}$ , respectively. The total system bandwidth resource, ‘C’ BU, has already been used out. (Hongwei et al. 2008 ;Pedrycz et al. 2001:39)

Then offered traffic can be written as,

$$A = \frac{\lambda^T}{\mu^T} \quad (5.32)$$

New call arrival rate is as follows,

$$\lambda^T = \sum_{k=1}^J [\lambda_{new}(k) + \lambda_h(k)] BW(k) \quad (5.33)$$

Service rate can be expressed as,

$$\mu^T = \sum_{k=1}^J [\mu_{new}(k) + \mu_h(k)] BW(k) \quad (5.34)$$

Where,  $BW(k)$  denotes the bandwidth resource demand of each call of class  $k$ .

### 5.5.2. Service differentiation

In this example we assume that we have three services to accommodate so  $k=3$ , voice, video, and data. According to the 3GPP QoS architecture, the three classes of services have the following relationship.

$$voice > video > data \quad (5.35)$$

Symbol “>” means “stricter then” when transmission rate and stability is considered. We considering bandwidth requirement we got following relation according to 3GPP QoS architecture.

$$BW_{\text{video}} > BW_{\text{data}} > BW_{\text{voice}} \quad (5.36)$$

We introduce priority coefficient,  $\alpha$ , and resource demand coefficient,  $\beta$ , to characterize and differentiate different classes of services. Therefore, for a new call or handoff call of any service type  $k$ , there is a unique vector  $(\alpha(k), \beta(k))$  to differentiate it from any other class of services. This vector is called *service differentiation vector*. The value of  $\alpha(k)$ , ( $0 \leq \alpha(k) \leq 1$ ) depends on the priority of class  $k$  service. The higher the priority of class  $k$  service is, the greater the value of  $\alpha(k)$  is. The resource demand coefficient,  $\beta(k)$ , ( $0 \leq \beta(k) \leq 1$ ). We assume that for any service type  $k$ , the control of  $P_{drop}(k)$  is more important than that of  $P_{block}(k)$ . A handoff call request is given higher priority than a new call request. (Hongwei et al. 2008)

Before the total system resource has been used out, all classes of services will be admitted with equal priorities as soon as they arrive. After the total system resource has been used out, priority-based waiting queues will be established to provide buffers for incoming handoff calls. The waiting queues are set up by different priorities. If it is a handoff call, the request will be processed; otherwise, the request will be rejected directly. Then for the incoming handoff call, we read the priority coefficient  $\alpha(k)$  from its service differentiation vector. Finally, the request is added to corresponding waiting queue according to the obtained  $\alpha(k)$ . For a specific queue, it is operated in a *First Come First Served (FCFS)* manner. Suppose that a counting process  $N^{(k)}(t)$  is used to describe class  $k$  service at time  $t$ .  $N^{(k)}(t)$  is then defined as follows:

$N^{(k)}(t)$  = total system resources consumed by all classes of services + buffering resources of priority- $\alpha(k)$  (waiting queue consumed by class  $k$  handoff calls) and the maximum buffering resources of each waiting queue is assumed to be  $Q$  BU. Actually,  $N^{(k)}(t)$  is a *continuous time Markov process*, with state space:

$$S = 0, 1, 2, 3, 4 \dots \dots \dots C, C + 1, \dots \dots \dots C + Q \quad (5.37)$$

In order to calculate  $P_{drop}(k)$  and  $P_{block}(k)$ , the counting process  $N^{(k)}(t)$  is modeled as a  $M/M/C/C+Q$ -type Markov queue, which can be analyzed by *birth-death process*. (Ma et al. 2005; Hongwei et al. 2008)

$$P_{drop}(k) = P_{C+Q}(k) \quad (5.38)$$

$$P_{block}(k) = \sum_{j=C}^{C+Q} P_j(k) \quad (5.39)$$

When the  $C$  (BU) system bandwidth has been used out the system has no more resources to allocate upon this point. Therefore, how to accommodate the successful competitors selected through the above model becomes a problem. (Hongwei et al. 2008)

To solve this, (Hongwei et al. 2008) propose an adaptive Fuzzy Service Degradation Control Model (FSDCM). While satisfying their QoS constraints, FSDCM degrades the QoS levels of existing services in the system so to release appropriate amount of resources, which will be used to accommodate more incoming handoff calls admitted by Priority-based Queuing Model (PQM).

### 5.5.3. Membership Functions

When its  $P_{drop}(k)$  increases above a reasonable level, FSDCM should *borrow* (by degrading existing services) system resources to admit more class  $k$  handoff calls so as to mitigate  $P_{drop}(k)$ . On the other hand, when  $P_{drop}(k)$  is under control and decreases to a satisfactory level, the borrowed resources should be returned (by upgrading the degraded existing services). FSDCM designed to seek a desirable tradeoff between *network recourse utilization* and *QoS of users*. The first input is  $\Delta_{drop}(k)$  where,

$P_{drop,tolerance}(k)$  is the worst-case handoff call dropping probability allowed by class  $k$  service. (Hongwei et al. 2008)

$$\Delta_{drop}(k) = P_{drop,tolerance}(k) - P_{drop}(k) \quad (5.40)$$

The second input is degradation degree, which is denoted as  $\gamma^D$ , ( $0 \leq \gamma^D \leq \gamma^D_{max} < 1$ ), where, the superscript D stands for taking the initial of “degradation”. Where,  $\gamma^D_{max}$  = maximum degradation degree in order to guarantee QoS of existing services,  $\gamma^D C_{BU}$  = incoming handoff calls after no resources left, while the  $(1 - \gamma^D)C$  = “squeezed” existing services to accommodate  $\gamma^D C$ .  $\gamma_{in}^D$ , and  $\gamma_{out}^D$  is output degradation degree how much is degradation to take decision on bases of fuzzy logic. The membership functions for in linguistic parameters are shown as,

$$\Delta_{drop}(k) = NB\Delta_{drop}, NS\Delta_{drop}, ZO\Delta_{drop}, PS\Delta_{drop}, PB\Delta_{drop} \quad (5.41)$$

As, NB= Negative Big, NS= Negative Small, ZO= Zero, PS= Positive Small, and PB= Positive Big.  $P(k)_{drop, tolerance}$  elements of set is defined as (Ma et al. 2005)

$$P_{drop,tolerance}(k) = -big, -small, 0, +small, +big \quad (5.42)$$

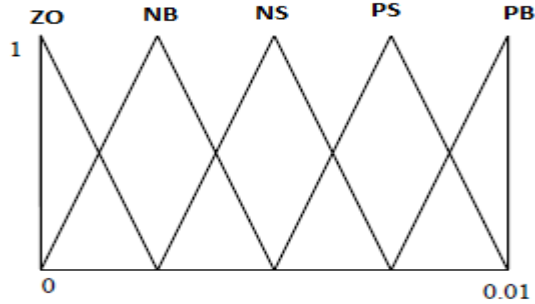
Fuzzy set of  $\gamma_{in}^D$  can be expressed as,

$$\gamma_{in}^D = VS_{Degrade}, S_{Degrade}, M_{Degrade}, L_{Degrade}, VL_{Degrade} \quad (5.43)$$

As, VS= Very Small, S= Small, M=Medium, L= Large and VL= Very Large.  $\gamma_{out}^D$  set of fuzzy is define as,

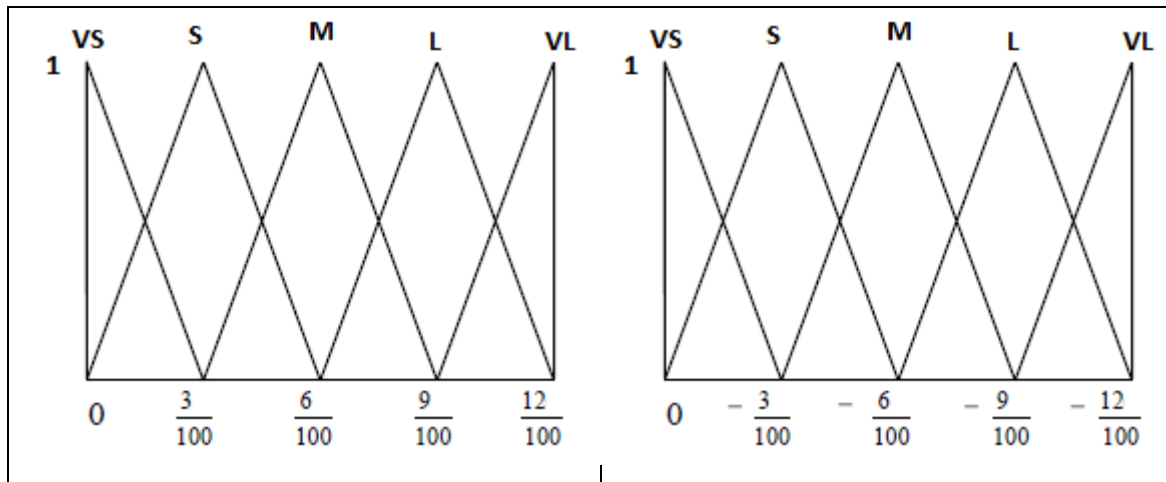
$$\gamma_{outD} = VS_{Degrade}, S_{Degrade}, M_{Degrade}, L_{Degrade}, VL_{Degrade} \quad (5.44)$$

The call dropping probability varies  $\Delta_{drop}(k)$  from 0 to 0.01 where, 0.01 is  $P_{drop,tolerance}(k)$ .



**Figure 19.** Membership functions for call dropping probability.

Suppose  $\gamma_{inD}$ , and  $\gamma_{outD}$  varies within the range from  $-12\%$  to  $+12\%$  of the total capacity degradation of a cell.



**Figure 20.** (a) Membership functions for positive degradation, (b) Membership functions for negative degradation.

The fuzzy interference rule is as follows,

**Table 2.** Fuzzy interference rule for negative degradation (Hongwei et al. 2008)

$\gamma_{out}^D$		$\Delta_{drop}(k)$				
		$NB\Delta_{drop}$	$NS\Delta_{drop}$	$ZO\Delta_{drop}$	$PS\Delta_{drop}$	$PB\Delta_{drop}$
$VS_{Degrade}$		$M_{Degrade}$	$S_{Degrade}$	$VS_{Degrade}$	$VS_{Degrade}$	$VS_{Degrade}$
$S_{Degrade}$		$L_{Degrade}$	$M_{Degrade}$	$S_{Degrade}$	$VS_{Degrade}$	$VS_{Degrade}$
$M_{Degrade}$		$VL_{Degrade}$	$L_{Degrade}$	$M_{Degrade}$	$S_{Degrade}$	$VS_{Degrade}$
$L_{Degrade}$		$VL_{Degrade}$	$VL_{Degrade}$	$L_{Degrade}$	$M_{Degrade}$	$S_{Degrade}$
$VL_{Degrade}$		$VL_{Degrade}$	$VL_{Degrade}$	$VL_{Degrade}$	$L_{Degrade}$	$M_{Degrade}$

**Table 3.** Fuzzy interference rule for positive degradation (Hongwei et al. 2008)

$\gamma_{in}^D$		$\Delta_{drop}(k)$				
		$NB\Delta_{drop}$	$NS\Delta_{drop}$	$ZO\Delta_{drop}$	$PS\Delta_{drop}$	$PB\Delta_{drop}$
$VS_{Degrade}$		$M_{Degrade}$	$S_{Degrade}$	$VS_{Degrade}$	$VS_{Degrade}$	$VS_{Degrade}$
$S_{Degrade}$		$L_{Degrade}$	$M_{Degrade}$	$S_{Degrade}$	$VS_{Degrade}$	$VS_{Degrade}$
$M_{Degrade}$		$VL_{Degrade}$	$L_{Degrade}$	$M_{Degrade}$	$S_{Degrade}$	$VS_{Degrade}$
$L_{Degrade}$		$VL_{Degrade}$	$VL_{Degrade}$	$L_{Degrade}$	$M_{Degrade}$	$S_{Degrade}$
$VL_{Degrade}$		$VL_{Degrade}$	$VL_{Degrade}$	$VL_{Degrade}$	$L_{Degrade}$	$M_{Degrade}$

#### 5.5.4. Adaptive Admission and Congestion Control logic

Fuzzy interference rule for degradation degree  $\gamma^D$ , is given in Table (2) and (3). Suppose ‘IF’ the change in dropping probability  $\Delta_{drop}(k)$  is  $PB\Delta_{drop}$ , ‘AND’ negative degradation  $\gamma_{out}^D$  is  $VL_{Degrade}$  ‘THEN’ tune Medium degradation  $M_{Degrade}$ . Similarly,

'IF' the change in dropping probability  $\Delta_{\text{drop}}(k)$  is  $PB\Delta_{\text{drop}}$ , 'AND' positive degradation  $\gamma_{\text{inD}}$  is  $VL_{\text{Degrade}}$  'THEN' tune Medium degradation  $M_{\text{Degrade}}$ .



## 6. ALGORITHMS ANALYSIS AND SIMULATION

The service intensity in a system is  $(\mu+\eta)$ . Service intensity for handoff call is  $\mu$  and for cell with no handoff is  $\eta$ . In simulation we considered that the total number of channels  $s=10$  both for NPS and RCS. We see a comparison of changing the value of handoff channels ( $Ch$ ) in system. As mention in above NPS has no reserved channels and we have fix number of users in cell. On the other hand, we have scenarios in RCS with reserved channels ( $Ch$ ). We simulate probabilities of  $Pb$ ,  $Ph$ ,  $Pft$ , and  $Pnc$  discussed in *chapter 3*, and relative effect of each probability on other. For all the cases, we assumed the mean call holding time for handoff call is  $\frac{1}{\mu}=3$ minutes and mean call holding time for call with no handoff is  $\frac{1}{\eta}$  also 3minutes.

Casa1:

Suppose we have 10 numbers of users in system then for no priority scheme (NPS) we have 10 channels (number of users (traffic load)). In reserved channel scheme (RCS) we have conditions  $n = s - (Ch)$  where,  $n$ = remaining number of channel left in system,  $s$ = total number of channels and  $Ch$ = reserved number of channels for handoff, for handoff channels ( $Ch$ ) = 5 (50% reserved channels).In  $n = s - (Ch)$  where  $n=5$ ,  $s=10$ .The call arrival intensity is  $A = \frac{\lambda}{\mu}$ , ranges from .6 to 3 erlang's.

Case2:

Suppose we have 10 numbers of users in system then for NPS we have 10 channels, In RCS we have conditions  $n = s - (Ch)$  where handoff channels ( $Ch$ ) = 2 (20% reserved channels).In  $n = s - (Ch)$  where  $n=8$ ,  $s=10$ . The call arrival intensity is  $A = \frac{\lambda}{\mu}$ , ranges from .6 to 3 erlang's.

### 6.1. Probabilities Comparison Steps

Step1: Define Total available channels in system, Total reserved channels for Handoff.

Step2: Define Call service intensities 'mu' and 'eta' to calculate value of  $\lambda_0$ , and offered traffic.

Step 3: If ch= reserved channel then,  $\lambda_{handoff} = 0$  else  $\lambda_{handoff} = 0.2 * \lambda_0$ .

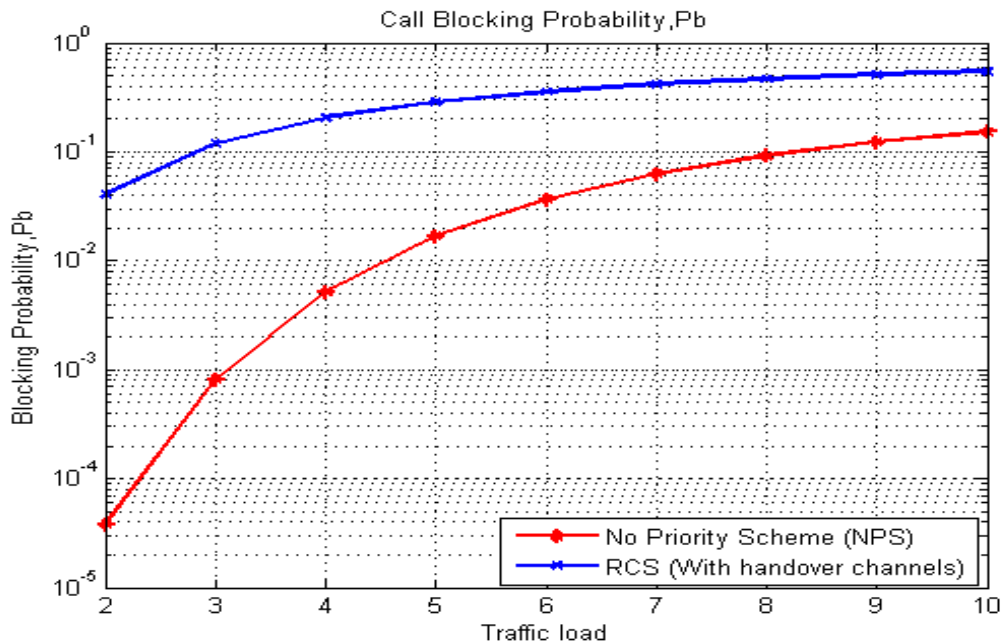
Step 4: Calculate call arrival intensity and initial blocking probability of system.

Step 5: Run the loop for 1000 seconds to get different points of blocking probabilities and dropping probability.

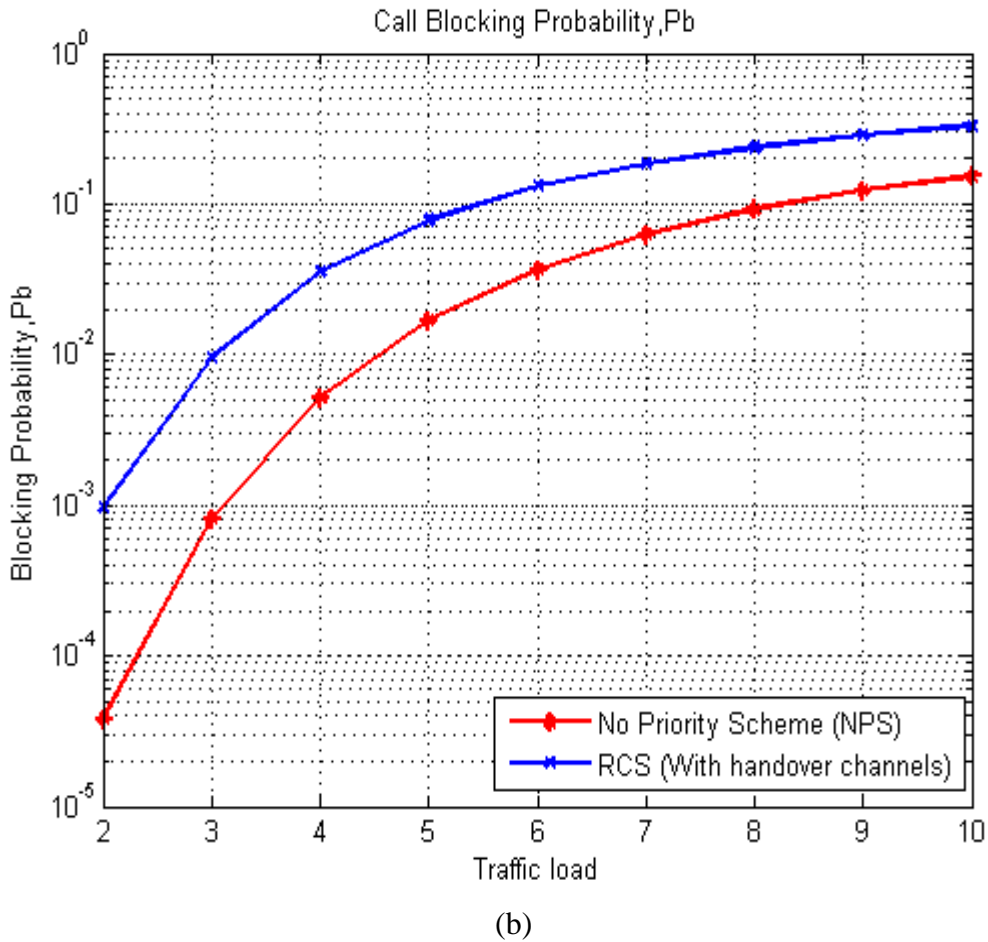
Step 6: Sum the blocking probabilities to get total blocking probability and dropping probability.

Step 7: Find the probabilities of call not completed which depends on call blocking probability, and call force termination probability that depends on dropping probability.

#### 6.1.1. Comparison of call Blocking Probability (Pb)

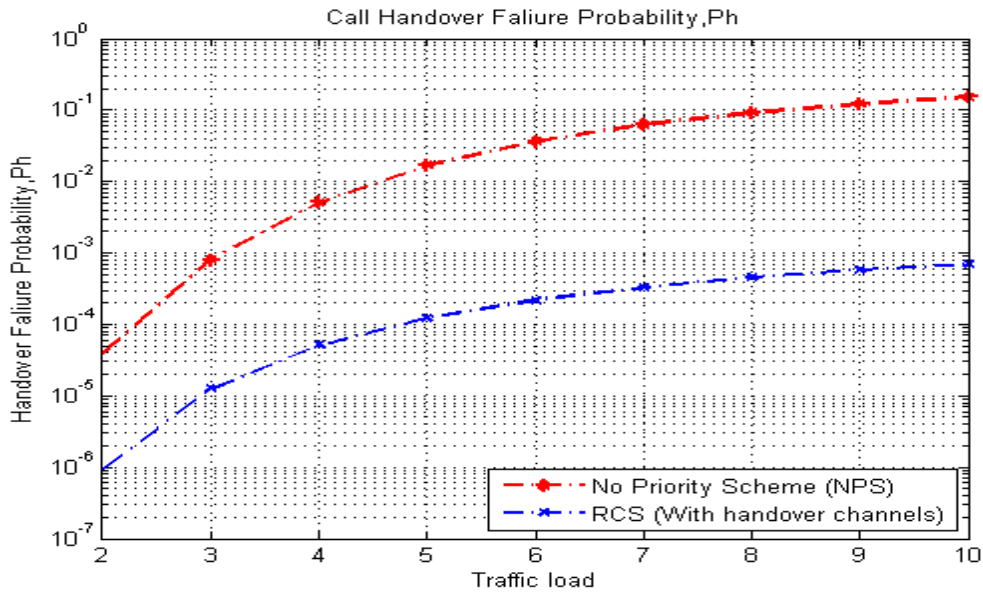


(a)

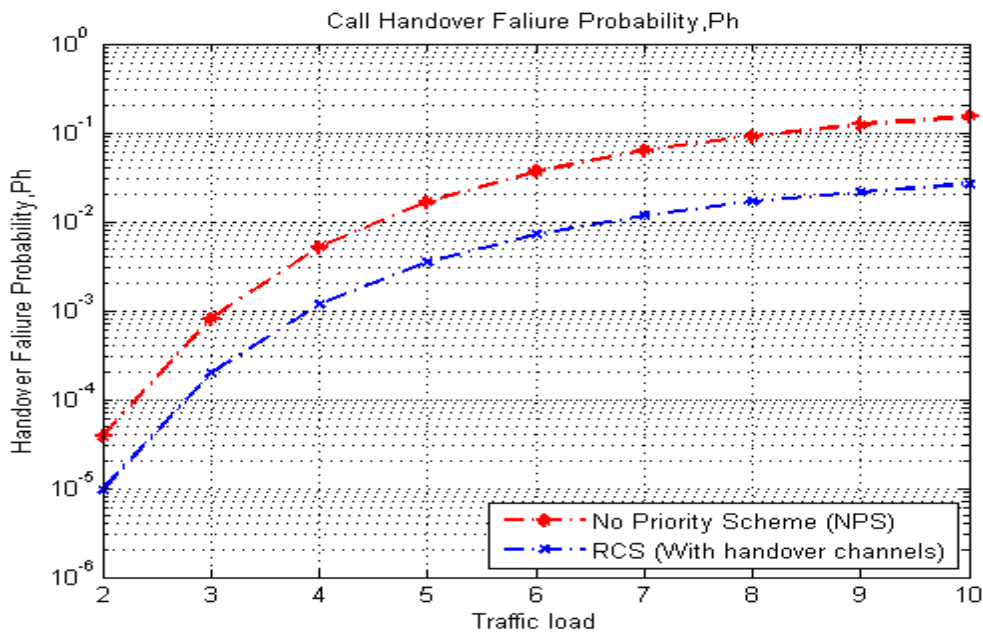


**Figure 21.** (a) Blocking probability  $P_b$  with  $s=10$  and  $Ch=5$  (50% reserved channels).  
 (b) Blocking probability  $P_b$  with  $Ch=2$  (20% reserved channels).

In case of RCS, as number reserved channels decrease the blocking probability of system decrease gradually as shown in Figure (21,a,b). It means when we decrease number of reserved channels, decrease in new calls probability can be seen and few more channels are available to accommodate new calls in system, but at the same time, we see increase in dropping of handoff calls. In case of NPS, blocking probability  $P_b$  remains same due to lack of reserved channels. From simulation, results showed above both in NPS and RCS cases blocking probability  $P_b$  increase with increase in number of busy channels. However, the greatest advantage in RCS scenarios we have guaranteed channel allocation for handoff users.

6.1.1. Comparison of Handoff dropping Probability ( $P_h$ )

(a)



(b)

**Figure 22.** (a) Handoff dropping Probability  $P_h$  with  $Ch=5$  (50% reserved channels). (b) Handoff dropping Probability  $P_h$  with  $Ch=2$  (20% reserved channels).

In case of RCS, decreasing the number of reserved channels call dropping of handoff calls probability of system increase gradually that can be seen in Figure (22,a,b) clearly. It means decreasing number of reserved channels we have increase in handoff failure probability  $P_h$  of calls, so we face the situation of call drop due to unavailability of guard channels. In case of NPS,  $P_h$  remains same due to lack of reserved channels. From results each simulation shown above for both NPS and RCS cases, handoff failure probability  $P_h$  increase with increase in number of busy channels.

In addition, NPS if all the channels are busy there is no channel for handoff call and in result handoff call faces dropping. On the other hand, even if all channels are busy we have  $(Ch)$  for handoff purposes. By decreasing number of channels for new calls, the chance of handoff of new call also decreases so handoff switching automatically reduces.

#### 6.1.2. Comparison of call Forced Termination Probability ( $P_{ft}$ )

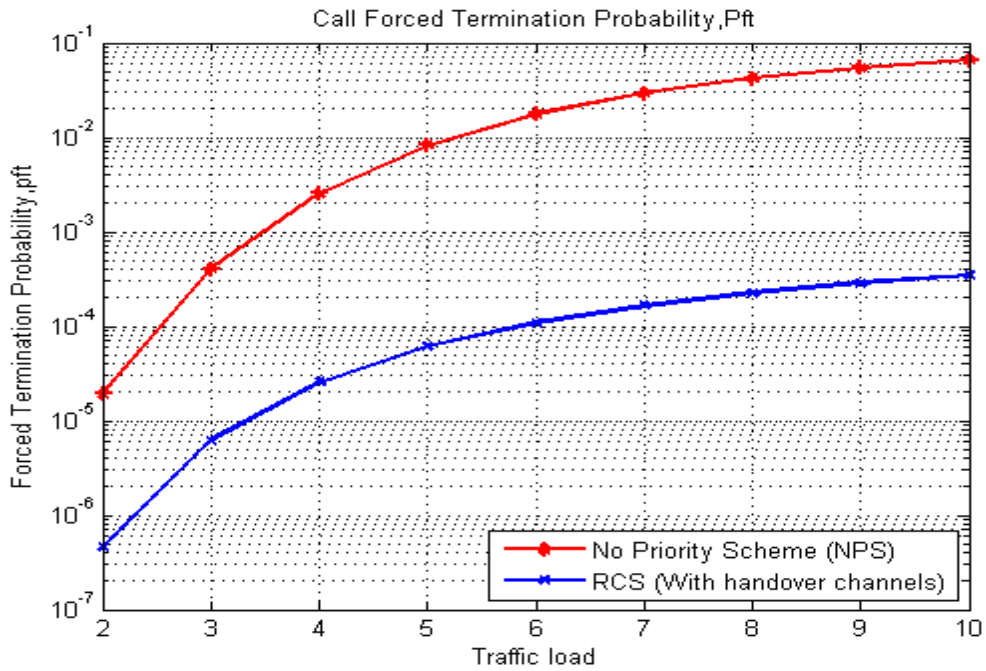
Probability that a new call origination in a particular cell accommodated by system is given in (Guerrero 1999) as,

$$S = \frac{(1 - P_b)}{(1 - P_b T)} \quad (6.1)$$

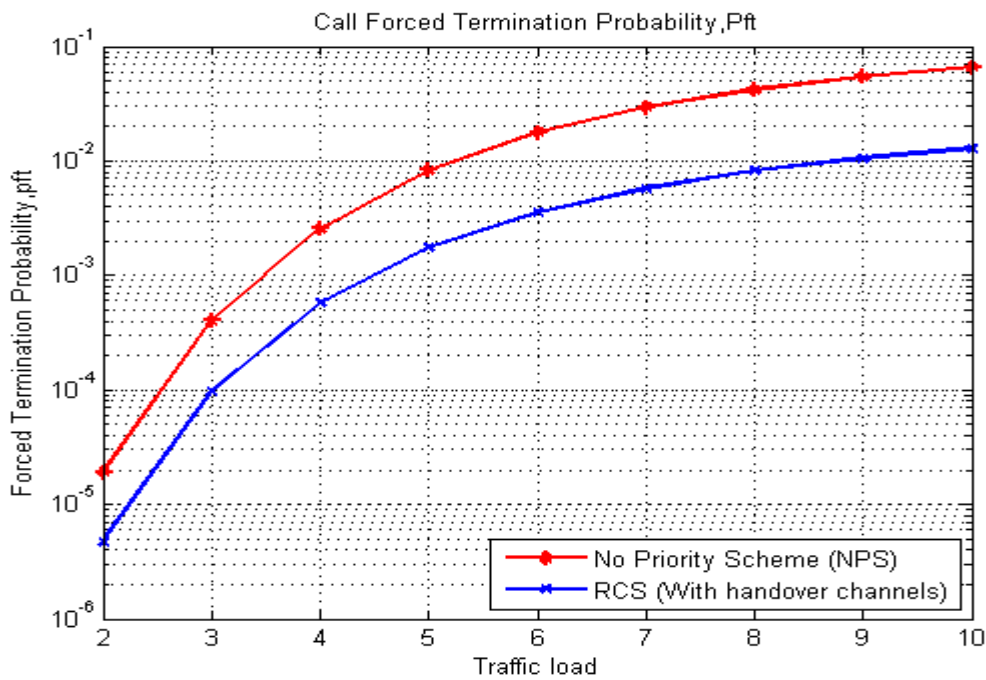
Probability that continuing call face forced termination after successful handoffs to a neighboring cell can be expressed as,

$$E = \frac{\eta p_h}{\mu + \eta p_h} \quad (6.2)$$

$$P_{ft} = S \times E \quad (6.3)$$



(a)



(b)

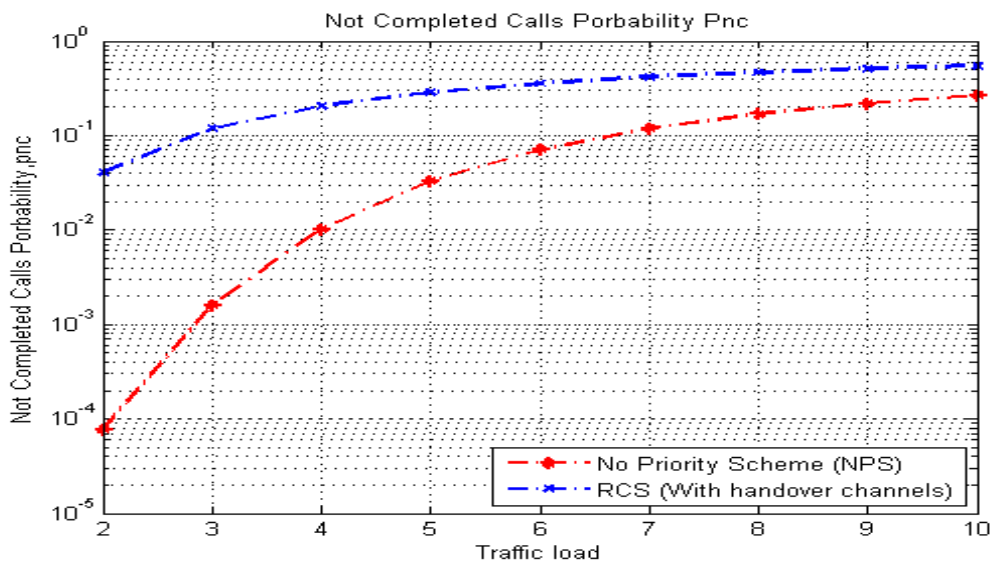
**Figure 23.** (a) Force termination probability  $P_{ft}$  with  $Ch=5$  (50% reserved channels). (b) Force termination probability  $P_{ft}$  with  $Ch=2$  (20% reserved channels).

Force termination  $P_{ft}$  means a handoff failure, when a call returns to its original call-originating cell after successful handoff to neighboring cell. Call force termination probability depends on occurrence of  $P_h$ . In case of RCS, decreasing the number of reserved channels Force termination probability of system increase gradually as shown in Figure (23 a, b). It means that, when we decrease number of reserved channels we have increase in Force termination probability  $P_{ft}$  of calls. The results for  $p_h$  and  $P_{ft}$  are almost same because it depends on  $P_h$ . From simulation showed above both for NPS and RCS cases,  $P_{ft}$  increase with increase in number of busy channels.

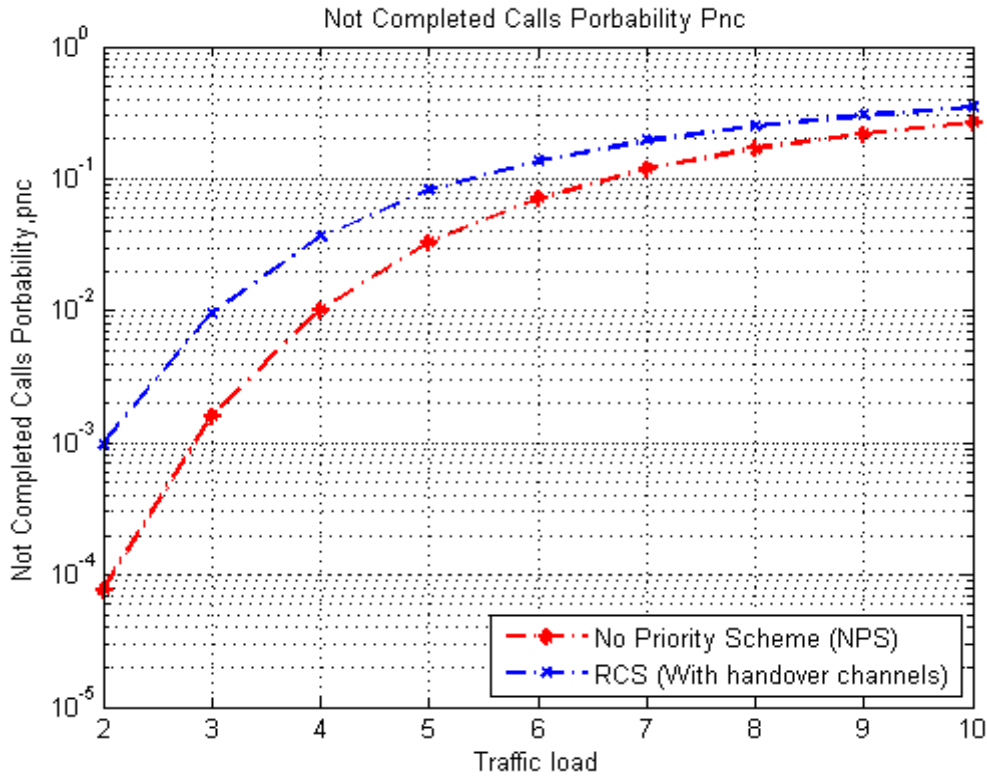
### 6.1.3. Comparison of call Not Completed Probability ( $P_{nc}$ )

Probability of not completing ( $P_{nc}$ ) in a cell are in (Guerrero 1999) as,

$$P_{nc} = 1 - \frac{1 - P_b}{1 + \frac{P_h \eta}{\mu}} \quad (6.4)$$



(a)



(b)

**Figure 24.** (a) Call Not Completed Probability ( $P_{nc}$ ) with  $Ch=5$  (50% reserved channels). (b) Call Not Completed Probability ( $P_{nc}$ ) with  $Ch=2$  (20% reserved channels).

In case of RCS, decreasing the number of reserved channels probability not completed calls  $P_{nc}$  of system decrease gradually as shown in Figure (24a, b). It means that, when we decrease number reserved channels we have decrease in  $P_{nc}$  of calls and few more channels for new calls will be available in system. Here,  $P_{nc}$  include call not complete due to either call blocking or call dropping in handoff. In case of NPS,  $P_{nc}$  remains same due to lack of reserved channels. From results, each simulation showed above both for NPS and RCS cases,  $P_{nc}$  increase with increase in number of busy channels. In case of RCS, Call Not Completed Probability  $P_{nc}$  has reduced by reduction in call blocking or call dropping in handoff.



#### 6.1.4. Recommendations

RCS should be use in cell where the number of user is high in system as number of users is high relative mobility increases and the chance of handoff call are more. Handoff failure reduced in RCS as compare to NPS. Accommodating handoff call in RCS plays important role in guaranteed call completion that increases significant GoS in cellular networks.

#### 6.2. Cell based call admission control Algorithm simulation

**Table 4.** Simulation parameters for cell-based Admission control with QoS.

Parameter	Value	Units
Total Bandwidth available, C	10	BBU
Class 1, $c_1$	4	BBU
Class 2, $c_2$	7	BBU
R1,R2,R3,R4	Variable	BBU
Call arrival rate	$\lambda$	Calls/sec/cell
$1/\mu$	Variable	Calls/sec/cell
$1/\eta$	Variable	Calls/sec/cell
$T_{sim}$	1000	seconds

The performance measures obtained through simulation are call blocking  $P_b$  and Handoff failure  $P_h$  probabilities.

### 6.3. Simulation for multi-class resource reservation

Step1: Define total available channels in system, total reserved channels for class1 Handoff, total reserved channels for class1 New calls, total reserved channels for class2 Handoff and total reserved channels for class2 New calls.

Step2: Define Call service intensities  $\mu$  and  $\eta$  to calculate value of  $\lambda_0$ , and offered traffic.

Step 3: If  $ch =$  reserved channel then,  $\lambda_{handoff} = 0$  else  $\lambda_{handoff} = 0.2 * \lambda_0$ .

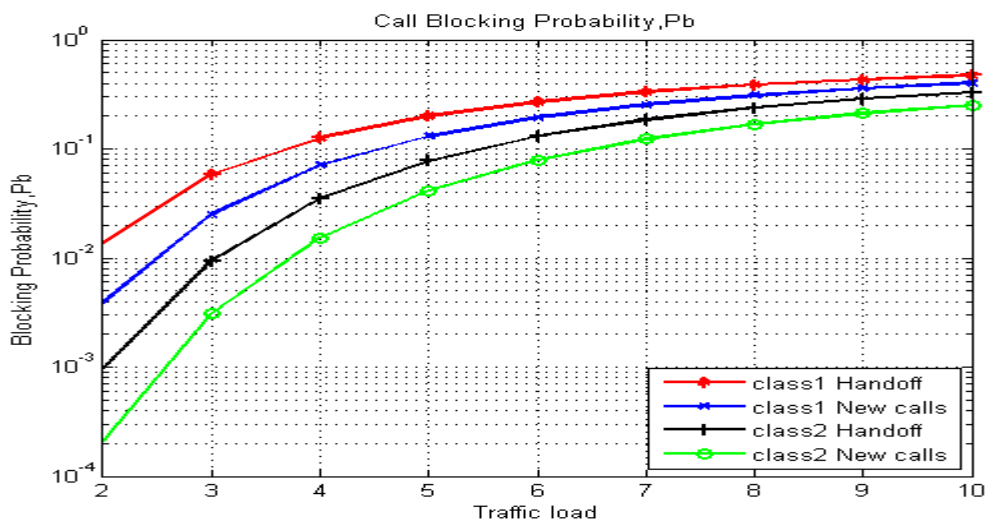
Step 4: Calculate call arrival intensities of each class and initial blocking probabilities of each class.

Step 5: Run the loop for 1000 seconds to get different points of blocking probabilities.

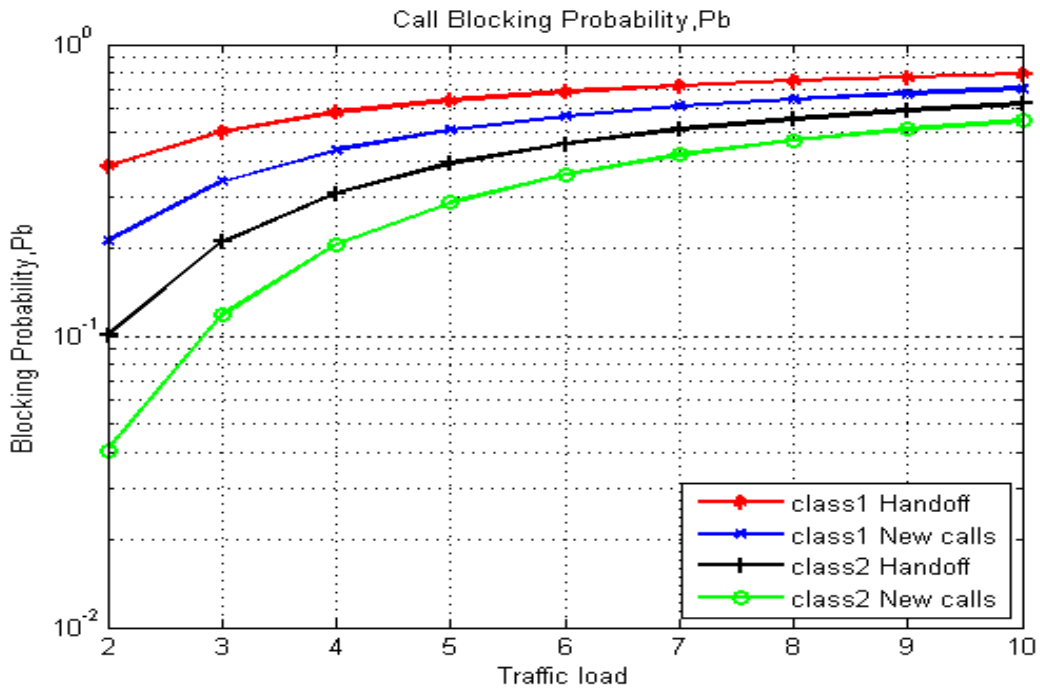
Step 6: Sum the blocking probabilities to get total blocking probability and dropping probability.

Step 7: Find the probabilities of call not completed which depends on call blocking probability.

### 6.4. Call blocking probability $P_b$ on channel sharing

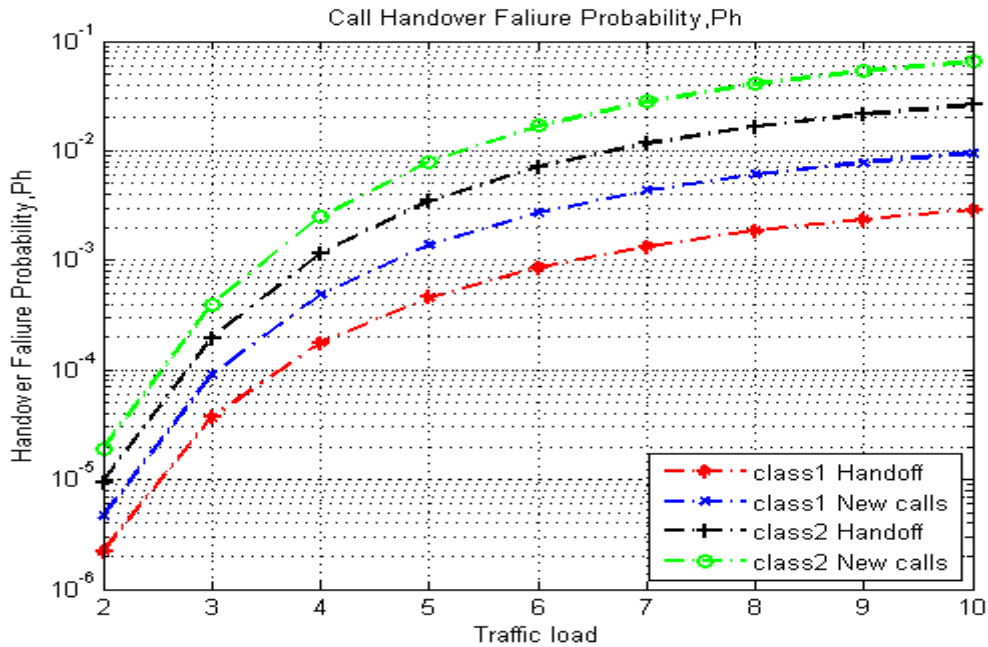


**Figure 25.** Call blocking probability  $P_b$  on channel sharing,  $s=10$ ,  $r_1=4$ ,  $r_2=3$ ,  $r_3=2$ ,  $r_4=1$ .

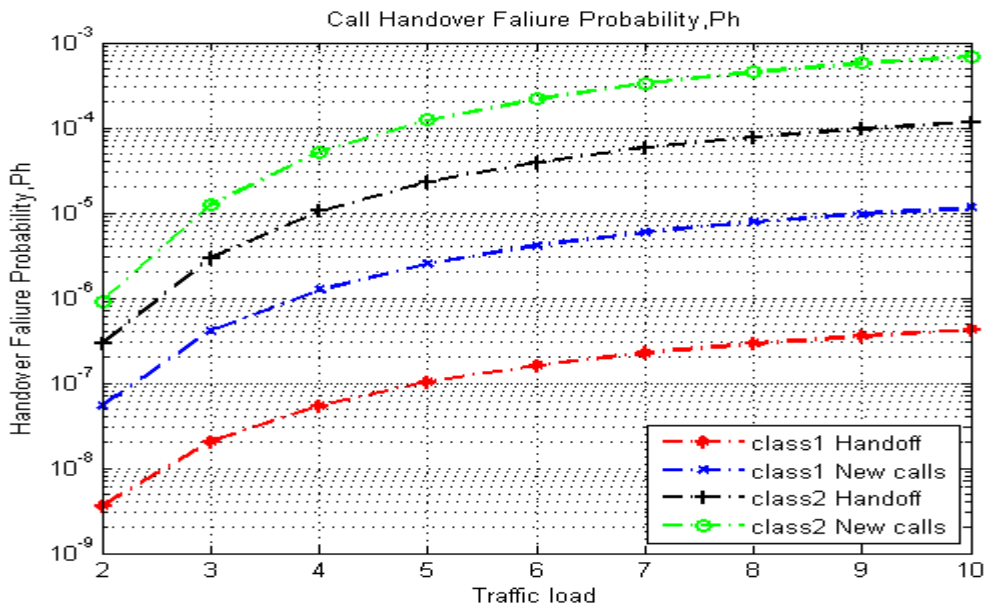


**Figure 26.** Call blocking probability  $P_b$  on channel sharing,  $s=10$ ,  $r_1=8$ ,  $r_2=7$ ,  $r_3=6$ ,  $r_4=5$ .

From Figure (25) and (26), as number reserved channels increases the blocking probability of system increases gradually. It means when we increase number of reserved channels, increases call blocking probability  $P_b$  but at the same time, we see decrease in dropping of handoff calls.

6.4.1. Handoff failure probability  $P_h$  on channel sharing

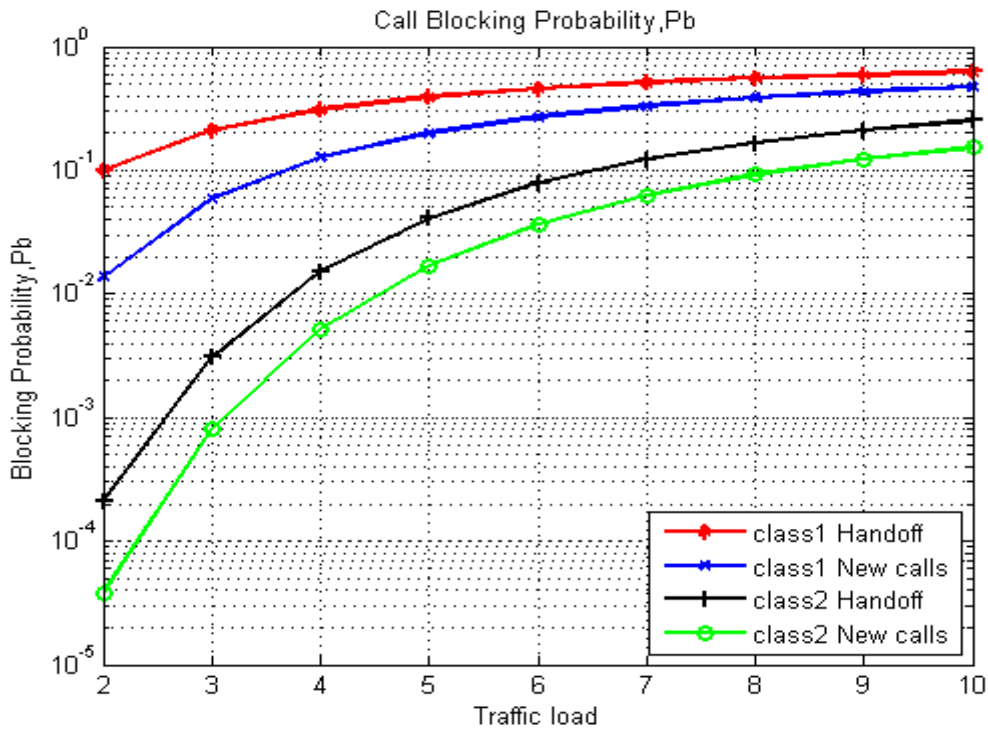
**Figure 27.** Handoff failure probability  $P_h$  on channel sharing,  $s=10$ ,  $r_1=4$ ,  $r_2=3$ ,  $r_3=2$ ,  $r_4=1$ .



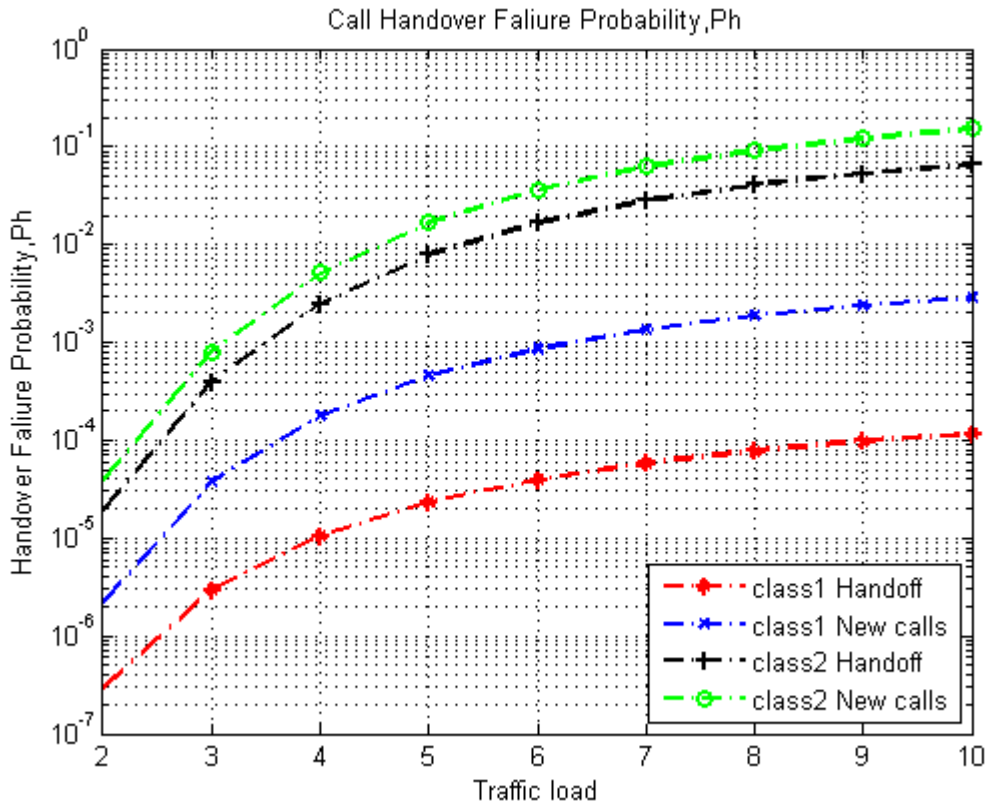
**Figure 28.** Handoff failure probability  $P_h$  on channel sharing,  $s=10$ ,  $r_1=8$ ,  $r_2=7$ ,  $r_3=6$ ,  $r_4=5$ .

From Figure (27) and (28), as increasing the number of reserved channels for each class call dropping of handoff calls probability of system decreases respectively in each class and depends on resource allocation to any particular class. It means decreasing number of reserved channels, we have increase in handoff failure probability  $P_h$  of calls, so we face the situation of call drop due to unavailability of guard channels in each class. In addition, even if all channels are busy we have  $r_1, r_2, r_3, r_4$  reserved channels for each class to accommodate incoming request in each class.

#### 6.4.2. Call blocking probability $P_b$ and handoff failure probability $P_h$ , in unfair resource allocation



**Figure 29.** Call blocking probability  $P_b$  in unfair resource allocation for class 2 new call traffic at  $s=10, r_1=6, r_2=4, r_3=1, r_4=0$ .



**Figure 30.** Handoff failure probability  $P_h$  in unfair resource allocation for class 2 new call traffic at  $s=10, r1=6, r2=4, r3=1, r4=0$ .

Now we see the impact on the blocking and dropping of calls on unfair resource allocation. For this suppose we choose the least priority class in system i.e. class-2 new calls. We can see from Figure (30) that class-2 new calls faces maximum handoff failure probability  $P_h$ . when the traffic load is low the performance of no priority and reservation scheme is identical because both have enough bandwidth to accept the arrival calls i.e. new or handoffs. However, when the call arrival rate is high and unused bandwidth increases that causes Call blocking probability  $P_b$  to increase. From Figure (30), we see a substantial improvement in Call dropping probability (CDP) because of bandwidth reservation admission control algorithm in chapter 4 that give priority to handoff calls results in low CDP. Reduction in CDP increases the QoS of a network. (Nasser et al.2007)

## 6.5. Power received graph, Propagation model GoS simulation

Step1: Define height of base station antenna in meters, height of receiving antenna of mobile station in meters, standard deviation of noise at Base station A, standard deviation of noise at Base station B, noise of A and B through standard deviation respectively, Carrier Frequency and distance between user and BS in Km.

Step2: Calculate path loss between MS and Base station A.

Step 3: Calculate path loss between MS and Base station B.

Step 4: Calculate power received at Base station A with noise and power received at Base station B with noise.

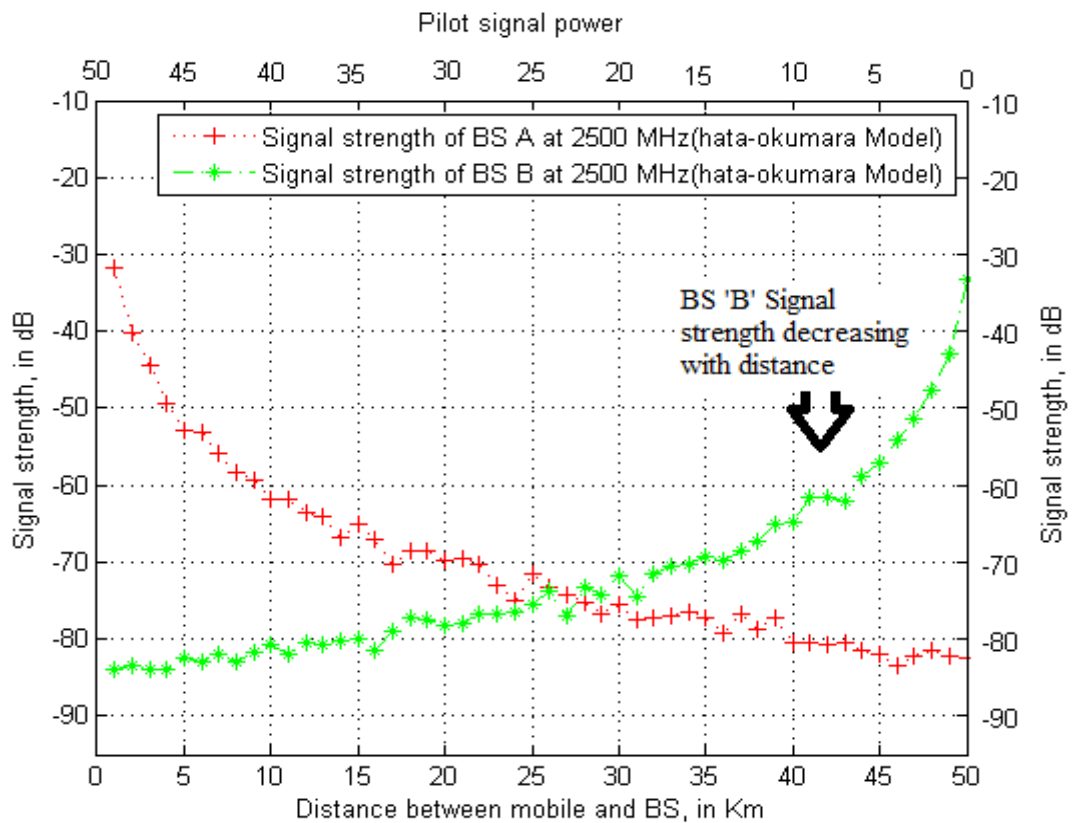
Step 5: Plot path loss between MS and Base station A and path loss between MS and Base station B.

Step 6: Plot power received at Base station A with noise and power received at Base station B with noise.

**Table 5.** Propagation model and GoS parameters

Propagation model parameters	
System Parameters	System Parameter Values
Carrier Frequency	2500 MHz
Height of base station antenna in meters	200m
Height of receiving antenna of mobile station in meters	1.5m
Distance between user and BS in Km	1-50Km
Urban area SUI Model	
$\gamma$ = Path loss parameters	a=4.6,b=0.0075,c=12.6
Wavelength $\lambda$	0.025
Reference distance= $d_0$	100m

GoS parameters	
Relative mobility of low mobility traffic	0.3
Relative mobility of medium mobility traffic	0.6
Relative mobility of high mobility traffic	0.9
Offered traffic in Erlang	20 Erlang
Total available channels	100
Number of reserved channels	Varies
Balancing factor for mobility $\alpha$	1



**Figure 31.** Power received from two base stations having Okumura propagation pathloss model at 1 dB Standard deviation.



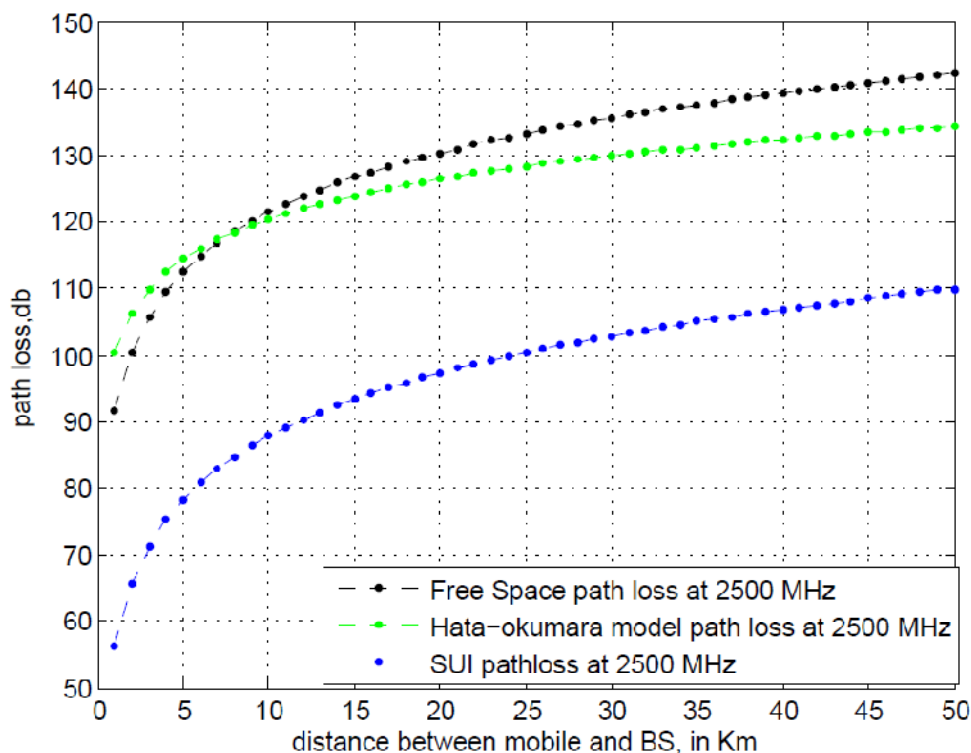
Figure (31), shows receives pilot signal of two base station using same propagation models to mitigate path loss. we have seen that the handoff occurs at 25Km from the base station which can cause rapid handoffs between cells and have increase call blocking probability and eventually degrade system GoS. The base station height is 200m at standard deviation (SD) 1dB.

The network Performance parameters also include handoff decisions based on signal measurement graph, Call blocking probability  $P_b$ , Handoff dropping Probability  $P_h$  and grade of service (GoS). As we considered low noise, handoff occurs at receive signal strength of -70 dB. The handoff margin is changes on the bases of traffic density. According to (Laiho et al. 2006:121) minimum noise at receiver antenna, receiver height and standard deviation results in quick and easy identification of possible problems and verification of overall network coverage, capacity and QoS. (Laiho et al. 2006:121)

When the receiving BS channel power is greater than the serving BS by a threshold level set by network administrator on bases of Bit error rate, traffic density, call blocking and dropping probability, grade of service (GoS), and defined QoS an bases of user demand then call is transferred and soft handoff occurred. Similarly, when the receiving BS power is less then threshold level of next queued BS then call disconnect from receiving BS and connected to other. Whenever, traffic load of network is high during busiest hour. The mobile station (MS) are moving fast and rapid within and between the cells. This increases the handoff intensity of network. To tackle this situation of rapid handoffs intensity the Outer loop power control consists of algorithms that calculate pilot signal strength in soft handoff. Soft handoff is different in a sense that the MS is communicating with number of base station to receive and get maximum of available received power.

In simulation shown in Figure (31), the MS is communicating with two BS at a time i.e., BS1, BS2 simultaneously. In the uplink, the mobile station (MS) use Omni-directional antenna. The two base stations receive the signals simultaneously in CDMA

systems. All received pilots signals have same CDMA frequency, due to frequency reuse factor. The BS, which receive better pilot is selected and other is discarded. In downlink, mobile station combine signals received from different BSs. An extra channel needed in downlink to tackle multipath effect. Soft handoff is a form of diversity, increasing the signal-to-noise ratio when the transmission power is constant. Soft handoff smoothes the movement of a UE from one cell to another, it helps to minimize the transmission power needed in both uplink and downlink. (Laiho et al. 2006:27)



**Figure 32.** Comparison of Path loss of free space, Hata-okumara and SUI pathloss models.

If we compare the path loss of above, mention Hata-okumara model and SUI model with free space path loss model at carrier frequency of 2500 MHz's we have seen a significant improvement in SUI model as compare to other.

## 6.5.1. Capacity of system and grade of service (GoS)

Step1: Define relative mobility of first mobile, relative mobility of second mobile, relative mobility of third mobile and offered traffic.

Step2: Define total number of channels available and reserved number of channels.

Step3: Sum the blocking probabilities to get total blocking probability and dropping probability.

Step 3: calculate GoS through  $P_{\text{block}} + \alpha P_{\text{drop}}$ ,  $\alpha > 1$ .

Step 4: Plot the GoS.

System capacity equation (3.14) in chapter 3, written as following:

$$P_j = \frac{(\rho_{\text{total}})^j}{j!} P_0 \quad \text{For } 0 \leq j < n \quad (6.5)$$

Then  $P_0$  is written as

$$P_0 = \frac{1}{\sum_{j=0}^n \frac{(\rho_{\text{total}})^j}{j!} + \sum_{j=n+1}^s \frac{(\rho_{\text{hi}})^{j-n} (\rho_{\text{total}})^n}{j!}} \quad (6.6)$$

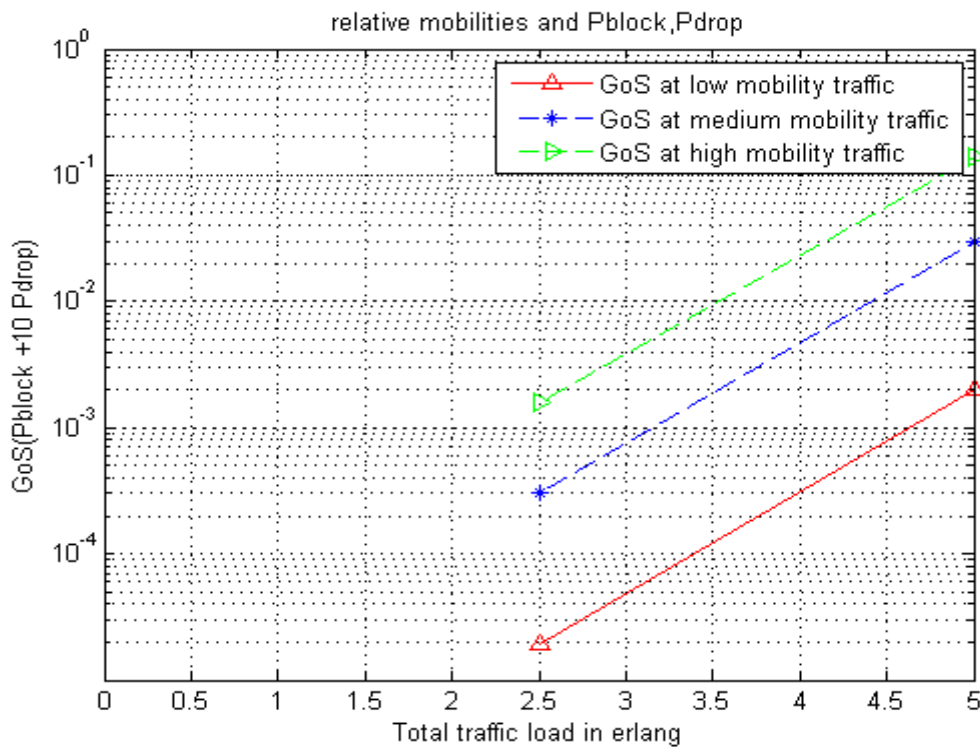
$$P_j = \frac{\frac{(\rho_{\text{total}})^j}{j!}}{\sum_{j=0}^n \frac{(\rho_{\text{total}})^j}{j!} + \sum_{j=n+1}^s \frac{(\rho_{\text{hi}})^{j-n} (\rho_{\text{total}})^n}{j!}} \quad \text{For } 0 \leq j < n \quad (6.7)$$

$$P_j = \frac{\frac{(\rho_{\text{hi}})^{j-n} (\rho_{\text{total}})^n}{j!}}{\sum_{j=0}^n \frac{(\rho_{\text{total}})^j}{j!} + \sum_{j=n+1}^s \frac{(\rho_{\text{hi}})^{j-n} (\rho_{\text{total}})^n}{j!}} \quad \text{For } n \leq j < s \quad (6.8)$$

As, relative mobility “a” is  $a = \frac{\lambda_{\text{hi}}}{\lambda_0 + \lambda_{\text{hi}}}$ . According to (Boumerdassi 2000), grade of service (GoS) of network can be written as

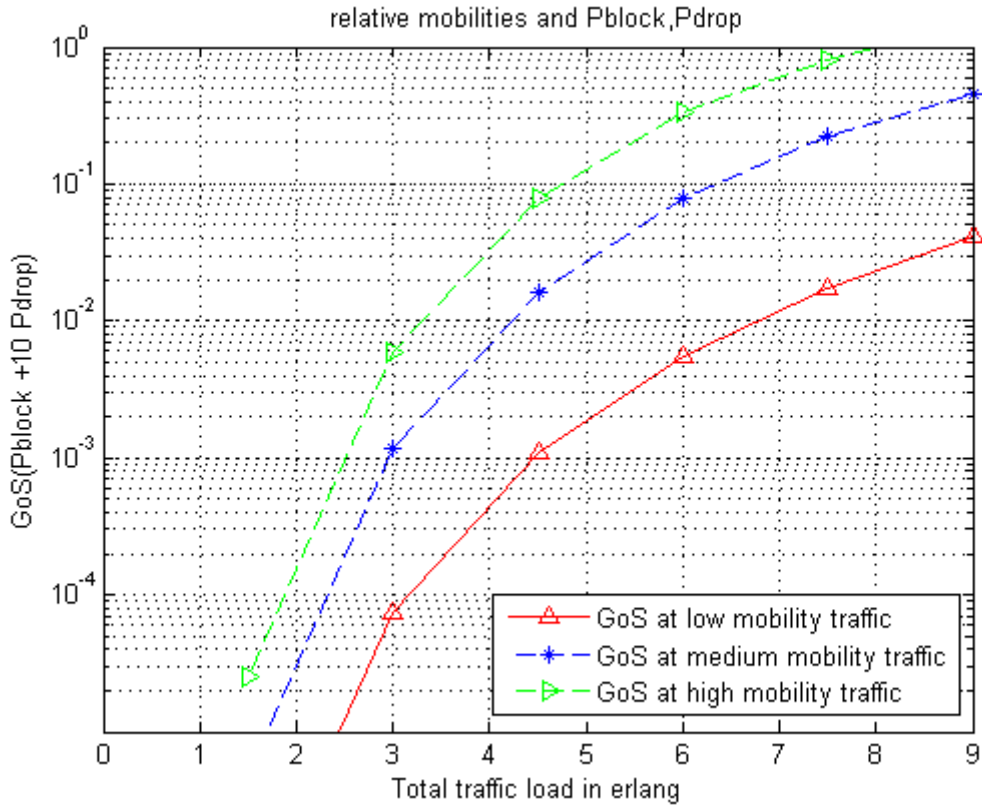
$$GOS = P_{block} + \alpha P_{drop}, \quad \alpha > 1 \quad (6.9)$$

Whereas,  $\alpha$  is balancing factor for different value of Relative mobility “ $a$ ”. GOS is the ability of a MS to get the access of trunk during busiest hour. Busy hour depends on time during  $\Delta t$ . (Boumerdassi 2000)



**Figure 33.** Grade of service (GoS) at Total channels,  $s=10$  at 5% blocking probability, reserved channels =4, offered traffic  $A=6$  erlang's.

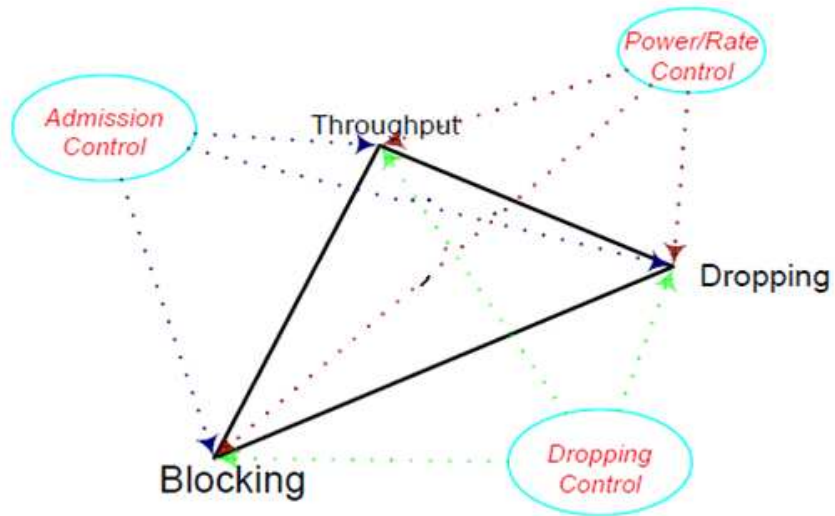
Increasing relative mobility introduces increase in Call blocking probability  $P_{block}$ , Handoff dropping Probability  $P_{drop}$ . As we have seen from Figure (33) that low mobility traffic has no effect on GoS but high mobility, traffic got blocking and dropping of approximately equal to 0.1%. As we increase the offered traffic of a network as shown in Figure (34) the blocking probability and dropping probabilities increases and we have seen unsuccessful call attempts in high mobility traffic.



**Figure 34.** Grade of service (GoS) at total channels,  $s=10$  at 20% blocking probability, reserved channels =4, offered traffic  $A=10$  erlang's.

### 6.5.2. Results and Conclusion

If network traffic is constant with variable relative, mobility “ $a$ ” it increase the Call blocking probability  $P_{block}$ , Handoff dropping Probability  $P_{drop}$ . We also know that force termination  $P_{ft}$  probability increase as handoff calls increase in system. As Relative mobility “ $a$ ” increase there are more chance of handoff as well. Relative mobility “ $a$ ” decrease cells capacity hence QoS of a system reduce.  $P_{ft}$  Probability has direct relation with handoff acceptance and availability of channel. Call blocking probability  $P_{block}$ , Handoff dropping Probability  $P_{h\_drop}$  has impact on traffic load. GoS increases with decrease in traffic load. There is tradeoff between  $P_{ft}$  probabilities handoff attempts.



**Figure 35.** Tradeoff for Admission control

We conclude from simulation results that there is always been a tradeoff between Throughput, blocking and dropping of calls base on power allocation and admission control algorithm used.

## 7. CONCLUSIONS AND FUTURE WORK

In this thesis, we have discussed the admission control problem on the bases of the availability of resources using two channel allocation schemes. We have analyzed the performances of channel allocation schemes named dynamic channel allocation schemes and cell bases call admission control schemes through simulation. We also analyzed two algorithms for dynamic channel allocation and cell bases call admission control for multi-class to get better QoS and minimum blocking and dropping of calls. Each of the above mentioned call admission control algorithms are implemented separately to check the variations in terms of call admit and call handoff rejection. The cell bases call admission control algorithm calculates bandwidth according to the priority level given to arrival call requests. It has also been proved within the scope of this thesis that reserved channel schemes (RCS's) based algorithms performs more efficient in high traffic and multi class environments. The channel allocation techniques have been designed to achieve certain objectives in terms of QoS and user needs. The implementation possibility of all the schemes depends on their individual performances and network demands. For instance, cell bases call admission control algorithm poor in reducing blocking probabilities but good in reduction of handoff dropping of calls.

In this thesis, power based adaptive call admission control combining the wideband power based (WPB) admission control and the throughput based (TB) admission control algorithms is discussed. According to (Subramanian et al. 2005; Islam 2008) adaptive call admission control algorithms work better then both above mentioned admission control algorithms. We have seen through simulation the efficiency of different pathloss models in urban environment. They have their individual benefits as per channel condition is concerned. We have discussed a adaptive call admission control scheme for multi-class services using adaptive fuzzy service degradation control model for congestion control when all the resources are already in used. The aim of this thesis is to analyze and explore the resource allocation techniques for the wireless systems. Thus, the resource allocation plays the key role for any wireless technology. This is the fact that makes us interested to do research in this topic.

#### Future work:

During my work on this thesis, I have realized that this topic is very wide and I could not handle all questions and problems that I have faced. Hence, I have decided to continue working in this research topic in future. Some of the research points are:

- More theoretical and practical analysis for the fuzzy-based admission control
- Fairness and Optimization in call admission control with QoS.
- Neural network and call admission control.



## REFERENCES

- Barceló Francisco (2004). Performance Analysis of Handoff Resource Allocation Strategies Through the State-Dependent Rejection Scheme. *IEEE Transactions on Wireless Communications*, Volume: 3, Issue: 3.
- Boumerdassi S. (2000). An efficient reservation-based dynamic channel assignment strategy . *First International Conference on 3G Mobile Communication Technologies*, No. 471 , 352 – 355
- F.A Cruz-Perez, Ortigoza-Guerrero L (2003). Adaptive resource allocation strategy with service type prioritisation for class-based QoS mobile networks. *IEEE International Communications Conference*, vol.3, 1685 - 1689
- Freeman Roger L. (2007). *Fundamentals of Telecommunications*. New York: John Wiley & Sons.
- Garg Vijay K. (2007). *Wireless Communications and Networking*. San Francisco: Elsevier Inc. ISBN 978-0-12-373580-5.
- Glisic Savo G. (2006). *Advanced Wireless Networks 4G Technologies*. West Sussex: John Wiley & Sons. ISBN 13 978-0-470-01593-3.
- Guerrero Ortigoza L., Aghvami A.H. (1999). A prioritized handoff dynamic channel allocation strategy for PCS. *IEEE Transactions on Vehicular Technology*, Volume: 48, Issue: 4 ,1203 – 1215.

- Hammuda Husni (1997). Cellular Mobile Radio Systems: Designing Systems for Capacity Optimization. West Sussex: John Wiley & Sons Ltd. ISBN 0-471-95641-4.
- Holma Harri and Antti Toskala (2004). 3G Wcdma For Umts Radio Access For 3G Mobile Communications West Sussex: John Wiley & Sons. ISBN: 0-470-87096-6.
- Hongwei Liao, Xinbing Wang, Hsiao-Hwa Chen (2008). Adaptive Call Admission Control for Multi-Class Services in Wireless Networks. IEEE International Conference on Communications, p 2840 – 2844
- Islam S.F., Hossain M.F. (2008). Comparison Study of various Call Admission Control Scheme in WCDMA Network. International Conference on Electrical and Computer Engineering. P 217 – 220
- Janevski Toni (2003). Traffic Analysis and Design of Wireless IP Networks. Norwood: Artech House. ISBN 1-58053-331-0, P 91-132.
- Koivo H., Elmusrati M. (2009). System Engineering in Wireless Communications. West Sussex : John Wiley & Sons. ISBN: 9780470021781, p 217-235.
- Laiho Jaana, Achim Wacker, Tomas Novosad (2006). Radio Network Planning and Optimisation for UMTS. West Sussex: John Wiley & Sons Ltd. ISBN-13 978-0-470-01575-9.

- Lee William C. Y. (2006). *Wireless and Cellular Telecommunications*. New York: McGraw-Hill Companies.
- Ma Yufeng, Xiulin Hu, Yunyu Zhang, and Yimei Shi (2005). *Intelligent Call Admission Control Using Fuzzy Logic in Wireless Networks*. American Control Conference, p3981-3985
- Mishra Ajay R. (2007). *Advanced Cellular Network Planning and Optimization*. West Sussex: John Wiley & Sons. ISBN-13 978-0-470-01471-4.
- Nasser, N.H.; Guizani, S. (2007). *Analysis of a Cell-based Call Admission Control Scheme for QoS Support in Multimedia Wireless Networks*. International Conference on Computer Communications and Networks, 1250 – 1255.
- Pedrycz Witold, Athanasios Vasilakos (2001). *Computational Intelligence in Telecommunications Networks*. United States of America: CRC Press LLC. ISBN 0-8493-1075-X
- Rappaport Theodore S. (1998). *Wireless Communication Principle & Practice*. New York: Prentice hall., p 395-407.
- Sauter M. (2006). *Communication Systems for the Mobile Information Society*. West Sussex: John Wiley & Sons. ISBN-13 978-0-470-02676-2.
- Siddiqui, A.A. Zia, M.Y.I (2004). *New calls blocking analysis in cellular systems based on Markov chain model*. International Networking and Communication Conference, 69 – 72.

Stüber Gordon L. (2002). Principles of Mobile Communication. New York: Kluwer Academic Publishers. ISBN: 0-306-47315-1.

Subramaniam, K.; Nilsson A.A (2005). An analytical model for adaptive call admission control scheme in a heterogeneous UMTS-WCDMA system. IEEE International Conference on Communications, Volume: 5, 3334 – 3338.

Sun Yong (2007). Multi-hop Relay System Evaluation Methodology (Channel Model and Performance Metric). IEEE 802.16 Broadband Wireless Access Working Group.

Tse David, Pramod Viswanath (2005). Fundamentals of Wireless Communication. London: Cambridge University Press.

Willig Andreas (1999). A Short Introduction to Queueing Theory. Berlin: Technical University Berlin, Telecommunication Networks Group.